

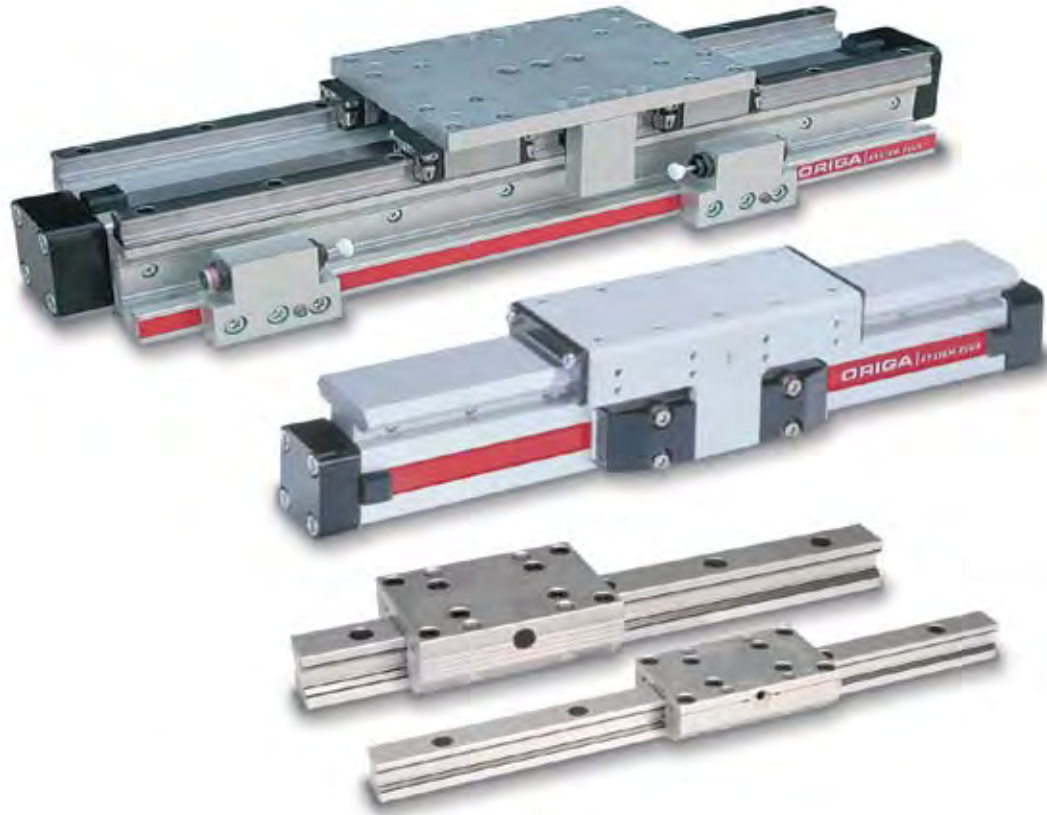

aerospace
climate control
electromechanical
filtration
fluid & gas handling
hydraulics
pneumatics
process control
sealing & shielding



OSP-P Pneumatic Rodless Cylinders and Linear Guides

Catalog 0980



ENGINEERING YOUR SUCCESS.

Warning, Offer of Sale

 **WARNING**

FAILURE OR IMPROPER SELECTION OR IMPROPER USE OF THE PRODUCTS AND/OR SYSTEMS DESCRIBED HEREIN OR RELATED ITEMS CAN CAUSE DEATH, PERSONAL INJURY AND PROPERTY DAMAGE.

This document and other information from Parker Hannifin Corporation, its subsidiaries and authorized distributors provide product and/or system options for further investigation by users having technical expertise. It is important that you analyze all aspects of your application including consequences of any failure, and review the information concerning the product or system in the current product catalog. Due to the variety of operating conditions and applications for these products or systems, the user, through its own analysis and testing, is solely responsible for making the final selection of the products and systems and assuring that all performance, safety and warning requirements of the application are met.

The products described herein, including without limitation, product features, specifications, designs, availability and pricing, are subject to change by Parker Hannifin Corporation and its subsidiaries at any time without notice.

Offer of Sale

The items described in this document are hereby offered for sale by Parker Hannifin Corporation, its subsidiaries or its authorized distributors. This offer and its acceptance are governed by the provisions stated on the separate page of this document entitled "Offer of Sale".

© Copyright 2009 Parker Hannifin Corporation. All Rights Reserved



Parker Hannifin Corporation
Parker-Origa
Glendale Heights, Illinois
www.parker.com/pneu/rodless

Index

<p>Introduction</p>	<ul style="list-style-type: none"> • Conversion Tables • System Concept • Modular Components Overview • Control Examples • Application Examples 	<p>A Introduction</p>
<p>Rodless Pneumatic Cylinders Series OSP-P</p>	<ul style="list-style-type: none"> • Overview • Rodless Pneumatic Cylinders • Rodless Pneumatic Cylinders with Guides • OSP-P Sensors & Service Parts • Origa SENSOFLEX Measuring System 	<p>B Rodless Cylinders Series OSP-P</p>
<p>Aluminum Roller Guides Series GDL</p>	<ul style="list-style-type: none"> • Linear Guide Features • GDL Product Line Overview • GDL Roller Guides / Accessories • Wipers / Butt-jointed Rail Options 	<p>C Aluminum Roller Guides Series GDL</p>
<p>Safety Guide, Offer of Sale</p>		<p>D Safety Guide, Offer of Sale</p>

Conversion Table**A****OSP**

— ORIGA

— SYSTEM

— PLUS

—
ELECTRIC ACTUATOR

**2D & 3D
CAD Drawings
can be downloaded
from website
www.parker.com/pneu/rodless**

ATTENTION!

Contact PARKER-ORIGA for sizing software
and/or technical assistance
630-871-8300

All dimensions are in European-Standard.
Please convert all in US-Standard.

Conversion Table

Multiply	By	To Obtain
Millimeters	.03937	Inches
Newtons	.2248	Lbs.(F)
Newton-Meters	8.8512	In-Lbs
Kilograms	2.205	Lbs.
Inches	25.4	Millimeters
Lbs.(F)	4.448	Newtons
In-Lbs	.113	Newtons-Meters
Lbs.	.45359	Kilograms

Certifications

PARKER-ORIGA rodless pneumatic cylinders are the first rodless cylinders that have been approved for use in potentially explosive atmospheres in Equipment Group II, Category 2 GD

The Cylinders are to the ATEX Certification 94/9/EG (ATEX 95) for Pneumatic Components.

For ATEX Certification, consult factory for ordering assistance.



for use in Ex-Areas

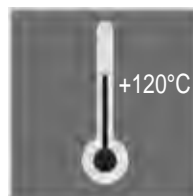

High Temperature Version for temperatures up to +120°C



for Clean Room Applications certified to DIN EN ISO 14644-1



Low Temperature Version for temperatures up to -40°C



Stainless steel version for special applications

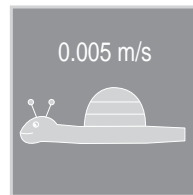

Slow Speed Version $v = 0.005 - 0.2 \text{ m/s}$

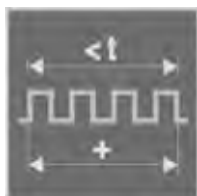

with special pneumatic cushioning system for cycle time optimization, for $\varnothing 16$ to 50 mm – on request



High Speed Version $v_{max.} = 30 \text{ m/s}$

The System Concept

One Concept – Three Drive Options

A

Based on the ORIGA rodless cylinder, proven in world wide markets, PARKER-ORIGA now offers the complete solution for linear drive systems. Designed for absolute reliability, high performance, ease of use and optimized engineering the ORIGA SYSTEM PLUS satisfies even the most demanding applications.

ORIGA SYSTEM PLUS

is a totally modular concept which offers the choice of pneumatic or electric actuation, with guidance and control modules to suit the exact needs of individual installations.

The actuators at the core of the system all have a common aluminum extruded profile, with double dovetail mounting rails on three sides, these

are the principle building blocks of the system to which all modular options are directly attached.



SYSTEM MODULARITY

• Pneumatic Drive

– For all round versatility and convenience, combining ease of control and broad performance capability. Ideally suited for point-to point operations, reciprocating movements and simple traverse / transfer applications.

• Electric Screw Drive

– For high force capability and accurate path and position control.

• Electric Belt Drive

– For high speed applications, accurate path and position control and longer strokes.

For additional information on electric linear actuators, please contact factory for OSP-E literature.













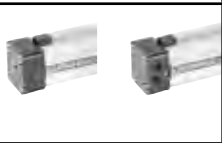
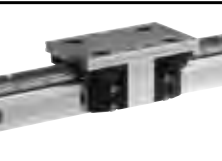

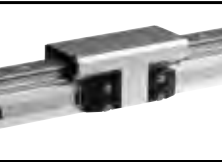

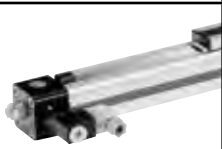
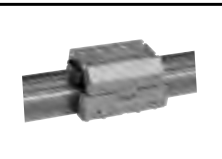
• Different guidance options provide the necessary level of precision, performance and duty for various applications.

• Compact solutions, which are simple to install and can be easily retrofitted.

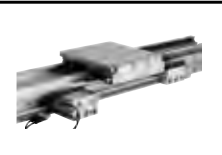
• Valves and control options can be directly mounted to the actuator system.

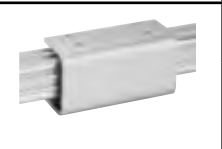
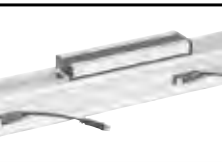
• Diverse mounting options to provide total installation flexibility.

* For information on Electric Linear Drives, contact factory for literature

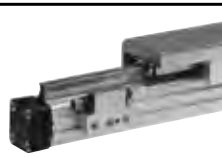
<p>Basic Linear Drive Standard Version</p> <ul style="list-style-type: none"> • Series OSP-P • Series OSP-E* Belt drive Belt drive with integrated Guides Vertical belt drive with recirculating ball bearing guide • Series OSP-E* Screw drive (Ball Screw, Trapezoidal Screw) 		<p>Linear Guides – SLIDELINE</p> <ul style="list-style-type: none"> • Series OSP-P • Series OSP-E Screw drive* 	
<p>Air Connection on the End-face or both at One End</p> <ul style="list-style-type: none"> • Series OSP-P 		<p>Linear Guides – POWERSLIDE</p> <ul style="list-style-type: none"> • Series OSP-P • Series OSP-E Belt drive* • Series OSP-E Screw drive* 	
<p>Clean Room Cylinder certified to DIN EN ISO 146644-1</p> <ul style="list-style-type: none"> • Series OSP-P • Series OSP-E..SB 		<p>Linear Guides – PROLINE</p> <ul style="list-style-type: none"> • Series OSP-P • Series OSP-E Belt drive* • Series OSP-E Screw drive* 	
<p>Bi-parting Version</p> <ul style="list-style-type: none"> • Series OSP-P 		<p>Linear Guides – STARLINE</p> <ul style="list-style-type: none"> • Series OSP-P 	
<p>Integrated 3/2 Way Valves</p> <ul style="list-style-type: none"> • Series OSP-P 		<p>Linear Guides – KF</p> <ul style="list-style-type: none"> • Series OSP-P 	
<p>Clevis Mounting</p> <ul style="list-style-type: none"> • Series OSP-P • Series OSP-E Belt drive* • Series OSP-E Screw drive* 		<p>Heavy Duty Linear Guides – HD</p> <ul style="list-style-type: none"> • Series OSP-P • Series OSP-E Screw drive* 	
<p>End Cap Mounting</p> <ul style="list-style-type: none"> • Series OSP-P • Series OSP-E Belt drive* • Series OSP-E Screw drive* 		<p>Intermediate Stop Module – ZSM</p> <ul style="list-style-type: none"> • Series OSP-P 	
<p>Mid-Section Support</p> <ul style="list-style-type: none"> • Series OSP-P • Series OSP-E Belt drive* • Series OSP-E Screw drive* 		<p>Brakes</p> <ul style="list-style-type: none"> • Active Brakes • Passive Brakes 	
<p>Inversion Mounting</p> <ul style="list-style-type: none"> • Series OSP-P • Series OSP-E Belt drive* • Series OSP-E Screw drive* 		<p>Magnetic Switches</p> <ul style="list-style-type: none"> • Series OSP-P • Series OSP-E Belt drive* • Series OSP-E Screw drive* 	
<p>Standard Version</p> <ul style="list-style-type: none"> • Series OSP-P 		<p>SENSOFLEX – Measuring System</p> <ul style="list-style-type: none"> • Series SFI-plus 	
<p>Multiplex Connection</p> <ul style="list-style-type: none"> • Series OSP-P 		<p>Variable Stop VS</p> <ul style="list-style-type: none"> • Series OSP-P with Linear Guide STL, KF, HD 	

A

Modular Components Overview

A

Linear Drives	OSP-P10	OSP-P16	OSP-P25	OSP-P32	OSP-P40	OSP-P50	OSP-P63	OSP-P80
Theoretical Force at 6 bar (N)	47	120	295	483	754	1178	1870	3010
Effective Force at 6 bar (N)	32	78	250	420	640	1000	1550	2600
Velocity v (m/s)	> 0.005	> 0.005	> 0.005	> 0.005	> 0.005	> 0.005	> 0.005	> 0.005
Magnetic Piston (three sides)	X	□	□	□	□	□	□	□
Lubrication - Prelubricated	□	□	□	□	□	□	□	□
Multiple Air Ports (4 x 90°)	X	□	□	□	□	□	□	□
Both Air Connections at End-face	X	○	○	○	○	○	○	○
Air Connection on the End-face	X	○	○	○	○	○	○	○
Cushioning	□	□	□	□	□	□	□	□
Cushioning Length (mm)	2,50	11	17	20	27	30	32	39
Stroke Length (mm) ▲	1 - 6000	1 - 6000	1 - 6000	1 - 6000	1 - 6000	1 - 6000	1 - 6000	1 - 6000
Pressure Range pmax (bar)	8.0	8.0	8.0	8.0	8.0	8.0	8.0	8.0
Temperature Range (°C) *	-10 – + 80	-10 – + 80	-10 – + 80	-10 – + 80	-10 – + 80	-10 – + 80	-10 – + 80	-10 – + 80
Viton / Chemical Resistance	○	○	○	○	○	○	○	○
Stainless Steel Parts	○	○	○	○	○	○	○	○
Clevis Mounting	○	○	○	○	○	○	○	○
Slow Speed Lubrication	○	○	○	○	○	○	○	○
Duplex Connection / Multiplex Connection	X	on request	○	○	○	○	on request	on request
Tandem Piston	○	○	○	○	○	○	○	○
Basic Cylinder								
F (N)	20	120	300	450	750	1200	1650	2400
Mx (Nm)	0.2	0.45	1.5	3	6	10	12	24
My (Nm)	1	4	15	30	60	115	200	360
Mz (Nm)	0.3	0.5	3	5	8	15	24	48
SLIDELINE								
F (N)	X	325	675	925	1500	2000	2500	2500
Mx (Nm)	X	6	14	29	50	77	120	120
My (Nm)	X	11	34	60	110	180	260	260
Mz (Nm)	X	11	34	60	110	180	260	260
PROLINE								
F (N)	X	542	857	1171	2074	3111	X	X
Mx (Nm)	X	8	16	29	57	111	X	X
My (Nm)	X	12	39	73	158	249	X	X
Mz (Nm)	X	12	39	73	158	249	X	X
POWERSLIDE								
F (N)	X	1400	1400 - 3000	1400 - 3000	3000	3000 - 4000	X	X
Mx (Nm)	X	14	14 - 65	20 - 65	65 - 90	90 - 140	X	X
My (Nm)	X	45	63 - 175	70 - 175	175 - 250	250 - 350	X	X
Mz (Nm)	X	45	63 - 175	70 - 175	175 - 250	250 - 350	X	X
STARLINE								
F (N)	X	1000	3100	3100	4000-7500	4000-7500	X	X
Mx (Nm)	X	15	50	62	150	210	X	X
My (Nm)	X	30	110	160	400	580	X	X
Mz (Nm)	X	30	110	160	400	580	X	X
- Variable Stop	X	○	○	○	○	○	X	X
KF Guide								
F (N)	X	1000	3100	3100	4000-7500	4000-7500	X	X
Mx (Nm)	X	12	35	44	119	170	X	X
My (Nm)	X	25	90	133	346	480	X	X
Mz (Nm)	X	25	90	133	346	480	X	X
- Variable Stop	X	○	○	○	○	○	X	X



Modular Components Overview

Linear Drives	OSP-P10	OSP-P16	OSP-P25	OSP-P32	OSP-P40	OSP-P50	OSP-P63	OSP-P80
HD Heavy Duty Guide								
F (N)	X	X	6000	6000	15000	18000	X	X
Mx (Nm)	X	X	260	285	800	1100	X	X
My (Nm)	X	X	320	475	1100	1400	X	X
Mz (Nm)	X	X	320	475	1100	1400	X	X
– Variable Stop	X	X	○	○	○	○	X	X
– Intermediate Stop Module	X	X	○	X	X	X	X	X
Active Brake								
Braking Force at 6 bar (brake surface dry) (N)	X	X	350	590	900	1400	2170	4000
SLIDELINE SL / PROLINE PL with Brakes								
Active Brake								
SL Braking Force at 6 bar (brake surface dry) (N)	X	X	325	545	835	1200	X	X
PL Braking Force at 6 bar (brake surface dry) (N)	X	X	on request	on request	on request	on request	X	X
Passive Brake Multibrake								
SL Braking Force at 6 bar (brake surface dry) (N)	X	X	470	790	1200	1870	2900	2900
PL Braking Force at 6 bar (brake surface dry) (N)	X	X	315	490	715	1100	–	–
Magnetic Switches								
Standard Version	○	○	○	○	○	○	○	○
T-Nut Version	○	○	○	○	○	○	○	○
Displacement Measuring Systems								
SFI-plus Incremental	X	X	○	○	○	○	○	○
Integrated Valves 3/2 WV NO VOE	X	X	○	○	○	○	on request	on request
Mountings								
End Cap Mounting / Mid-Section Support	○	○	○	○	○	○	○	○
Inversion Mounting	X	○	○	○	○	○	○	○
Shock Absorber for Intermediate Positioning	X	X	on request	on request	on request	on request	X	X
Adaptor Profile / T-Nut Profile	X	○	○	○	○	○	X	X
Special Cylinders								
Special Pneumatical Cushioning System	X	on request	on request	on request	on request	on request	X	X
Clean Room Cylinders to DIN EN ISO 14644-1	X	○	○	○	X	X	X	X
Bi-parting Version	X	X	X	X	○	X	X	X
High-Speed up to 30 m/s	X	on request	on request	on request	X	X	X	X

□ = Standard Version

▲ = Longer Strokes on Request

* = other temperature Ranges on Request

○ = Option

X = Not Applicable

A

A

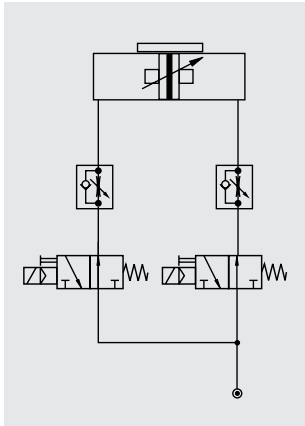

Circuit diagram for end of stroke application. Intermediate positioning is also possible.

The cylinder is controlled by two 3/2-way valves (normally open). The speed can be adjusted independently for both directions.

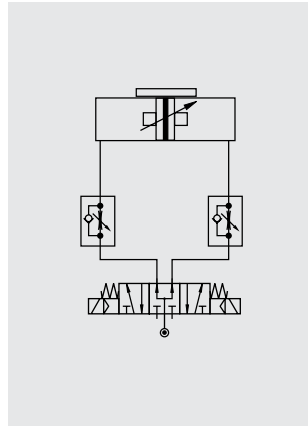

Circuit diagram for end of stroke application. Intermediate positioning is also possible.

The cylinder is controlled by a 5/3-way valve (middle position pressurized). The speed can be adjusted independently for both directions.

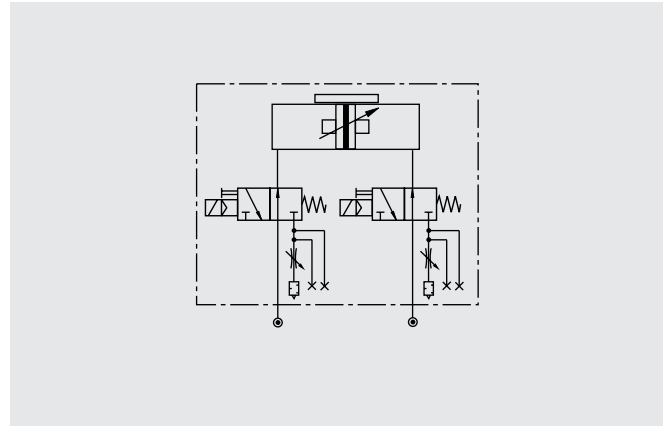

The optional integrated VOE Valves offer optimal control, and allow accurate positioning of intermediate positions and the lowest possible speeds.

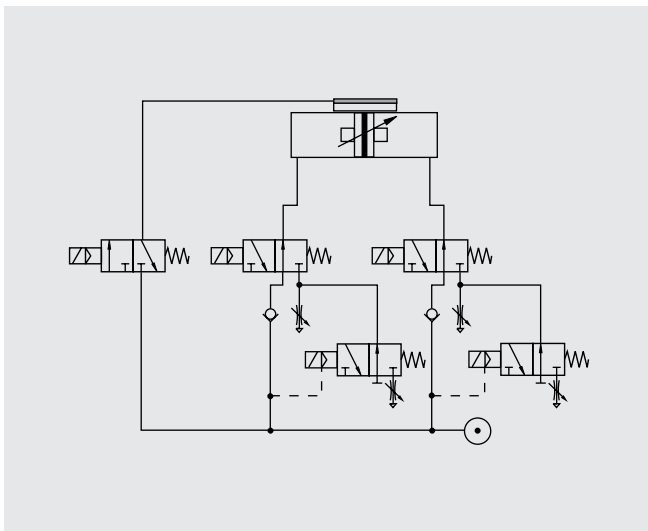

Fast/Slow speed cycle control with pneumatic brake for accurate positioning at high velocities. Additional 3/2-way valves with adjustable throttle valves at the exhaust of the standard directional control valves for two displacement speeds in each direction of the piston's travel. The valve controlling the brake is activated after the slow speed cycle is activated.

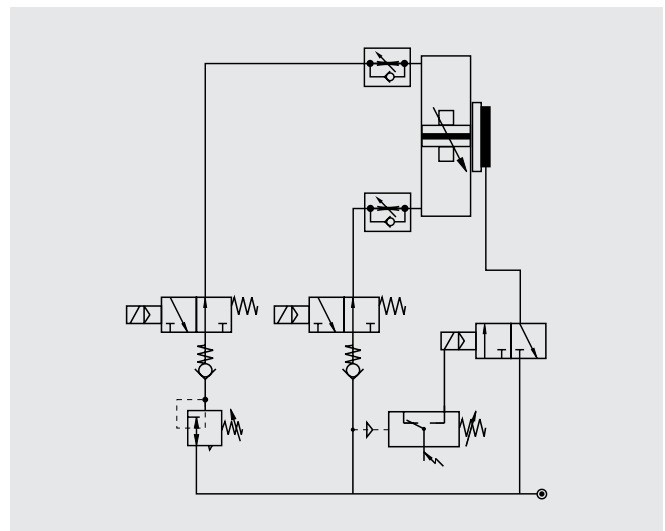

The combination of an OSP-cylinder with the passive MULTIBRAKE as shown here, allows accurate positioning and safety in case of loss of pneumatic air pressure.

ORIGA SYSTEM PLUS – rodless linear drives offer maximum flexibility for any application.

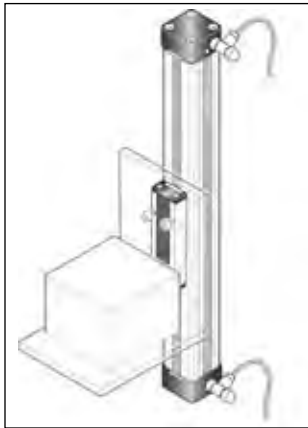

The high load capacity of the piston can cope with high bending moments without additional guides.

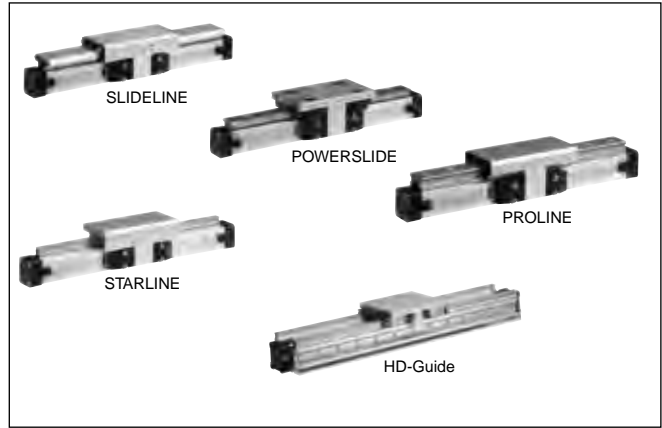

The mechanical design of the OSP-P allows synchronized movement of two cylinders.

Integrated guides offer optimal guidance for applications requiring high performance, easy assembly and maintenance free operation.

Optimal system performance by combining multi-axis cylinder combinations.

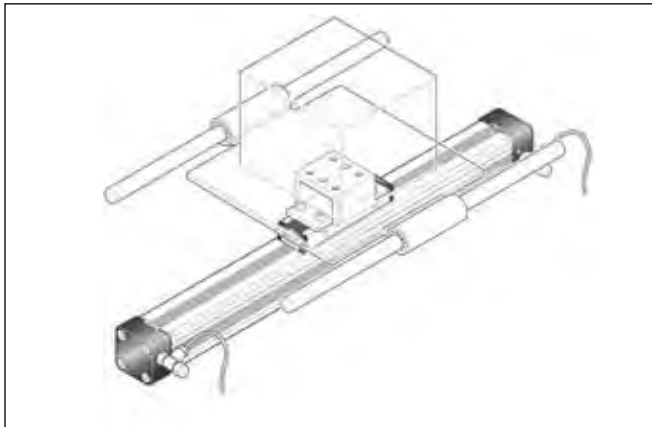

When using external guides, the clevis mounting is used to compensate for deviations in parallelism.



For further information and assembly instructions, please contact your local PARKER-ORIGA dealer.

Notes

A



Rodless Pneumatic Cylinders Series OSP-P

B

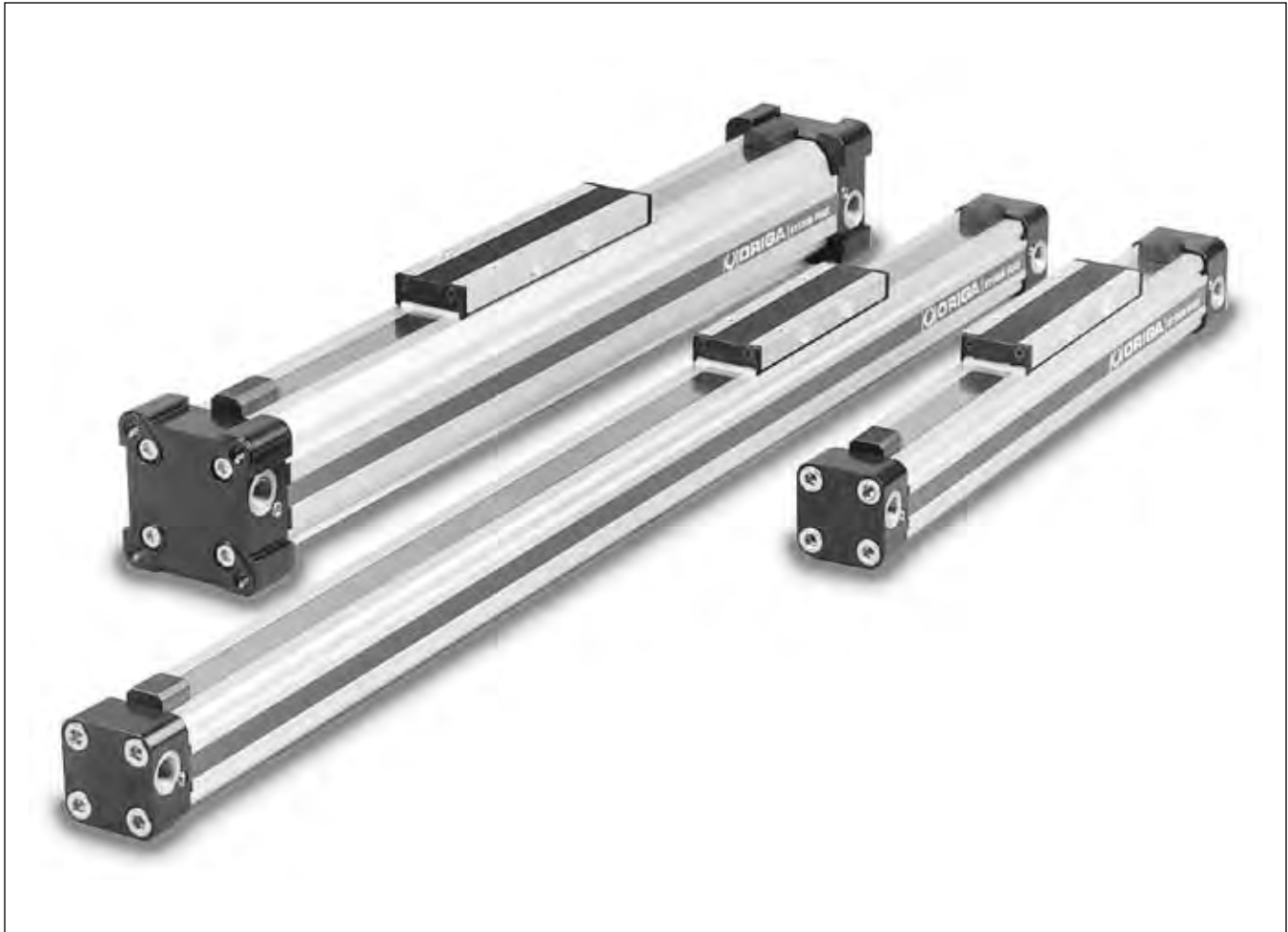

Standard Rodless Pneumatic Cylinders

System Concepts & Components	B2-B5
Technical Data	B7-B9
Dimensions.....	B10-B15
Active Brakes.....	B16-B19
Accessories (Mounts & Supports).....	B20-B29
Ordering Information	B30

Clean Room Cylinders

Technical Data	B31-B32
Dimensions.....	B33
Ordering Information	B34

Bi-parting Rodless Cylinders

Technical Data	B35
Dimensions.....	B36
Ordering Information	B37



ORIGA SYSTEM PLUS

– INNOVATION FROM A PROVEN DESIGN

A completely new generation of linear drives which can be simply and neatly integrated into any machine layout.

B

A NEW MODULAR LINEAR DRIVE SYSTEM

With this second generation linear drive PARKER-ORIGA offers design engineers complete flexibility. The well known ORIGA cylinder has been further developed into a combined linear actuator, guidance and control package. It forms the basis for the new, versatile ORIGA SYSTEM PLUS linear drive system.

All additional functions are designed into modular system components which replace the previous series of cylinders.

MOUNTING RAILS ON 3 SIDES

Mounting rails on 3 sides of the cylinder enable modular components such as linear guides, brakes, valves, magnetic switches etc. to be fitted to the cylinder itself. This solves many installation problems, especially where space is limited.

The modular system concept forms an ideal basis for additional customer-specific functions.

Magnetic piston as standard - for contactless position sensing on three sides of the cylinder.

Corrosion resistant steel outer sealing band and robust wiper system on the carrier for use in aggressive environments.

Proven corrosion resistant steel inner sealing band for optimum sealing and extremely low friction.

Combined clamping for inner and outer sealing band with dust cover.

Stainless steel screws optional.

Low friction piston seals for optimized running characteristics

Optimized cylinder profile for maximum stiffness and minimum weight. Integral air passages enable both air connections to be positioned at one end, if desired.

End cap can be rotated to any one of the four positions (before or after delivery) so that the air connection can be in any desired position.



Clean Room Version
certified to DIN EN ISO 14644-1

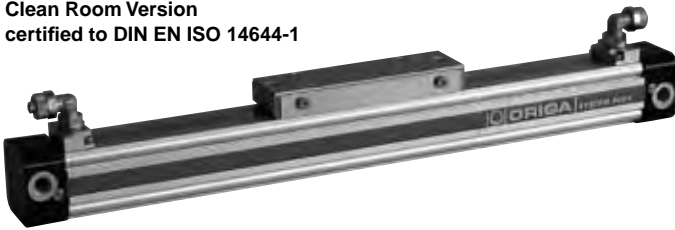

Rodless Cylinder
for synchronized bi-parting movements

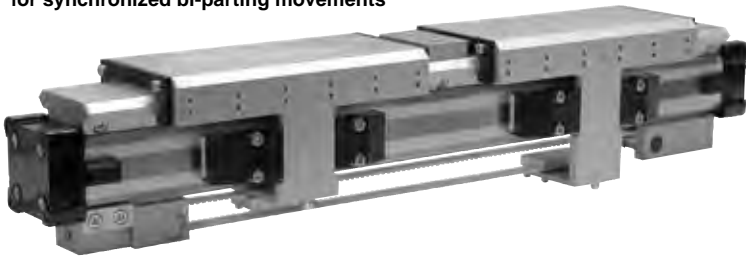

New low profile
piston / carrier design.

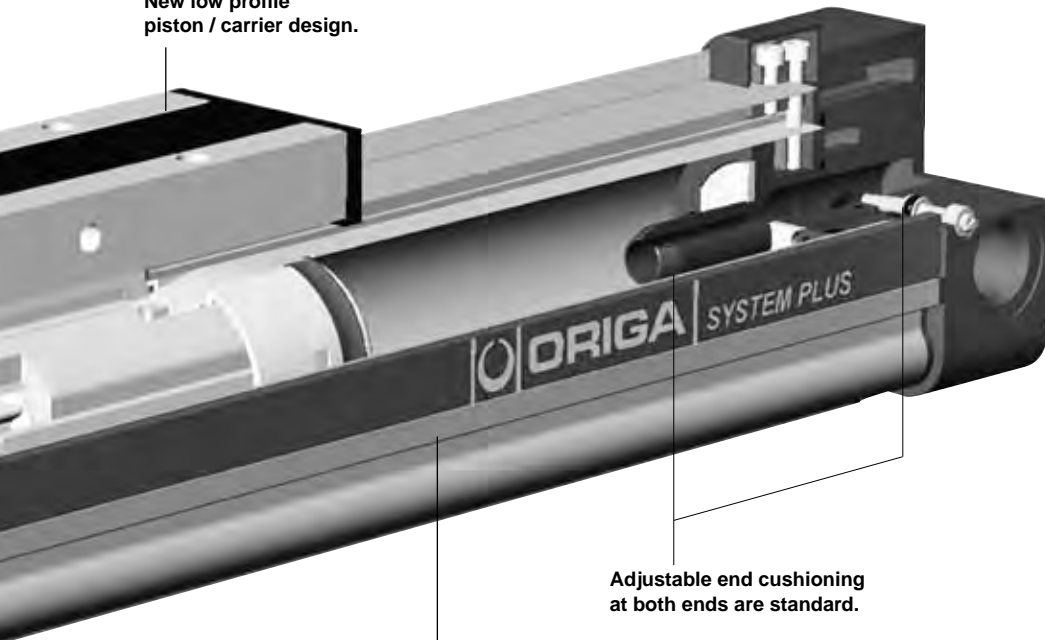

Adjustable end cushioning
at both ends are standard.

Integral dovetail rails on three sides
provide many adaptation possibilities
(linear guides, magnetic switches, etc.).

Modular system components
are simply clamped on.

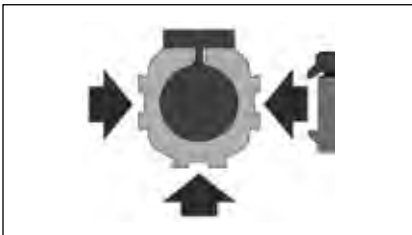

INTEGRATED
VOE VALVES
The complete
compact solution
for optimal cylinder
control.

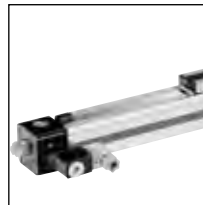

SENSOFLEX
SFI-plus
incremental
measuring system
with 0.1 (1.0) mm
resolution

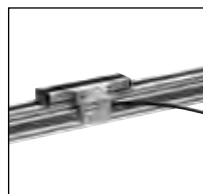

SLIDELINE
Combination with
linear guides
provides for
heavier loads.

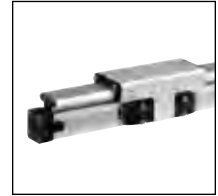

POWERSLIDE
Roller bearing
precision guidance
for smooth travel
and high dynamic
or static loads.



PROLINE
The compact
aluminum roller
guide for high loads
and velocities.



STARLINE
Recirculating ball
bearing guide for
very high loads
and precision



KF GUIDE
Recirculating ball
bearing guide – the
mounting dimensions
correspond to FESTO
Type: DGPL-KF

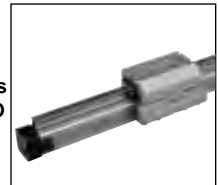

HEAVY DUTY
GUIDE HD
for heavy duty
applications.

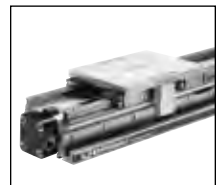

VARIABLE STOP VS
The variable stop
provides simple
stroke limitation.



Passive pneumatic
brake reacts
automatically to
pressure failure.



Active pneumatic
brake for secure,
positive stopping
at any position.

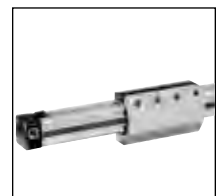

OPTIONS AND ACCESSORIES FOR SYSTEM VERSATILITY

SERIES OSP-P

STANDARD VERSIONS OSP-P10 to P80

Pages B7-B15

Standard carrier with integral guidance. End cap can be rotated 4 x 90° to position air connection on any side.

Magnetic piston as standard. Dovetail profile for mounting of accessories and the cylinder itself.

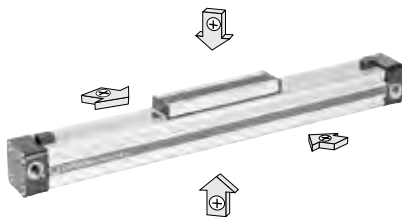

BASIC CYLINDER OPTIONS

CLEAN ROOM CYLINDERS

Page B31-B34

For use in clean room applications, certified with the IPA-Certificate (to DIN EN ISO 14644-1).

The special design of the linear drive enables all emissions to be led away.



STAINLESS VERSION

For use in constantly damp or wet environments. All screws are A2 quality stainless steel



SLOW SPEED OPTIONS

Specially formulated grease lubrication facilitates slow, smooth and uniform piston travel in the speed range from 0.005 to 0.2 m/s.



Minimum achievable speeds are dependent on several factors. Please consult our technical department.

Slow speed lubrication in combination with Viton® on demand.

Oil free operation preferred.

VITON® VERSION

For use in an environment with high temperatures or in chemically aggressive areas.



All seals are made of Viton®.

Sealing bands: Stainless steel

END-FACE AIR CONNECTION

Page B12

To solve special installation problems.



BOTH AIR CONNECTIONS AT ONE END

Page B13

For simplified tubing connections and space saving.



INTEGRATED VOE VALVES

Page B14

The complete compact solution for optimal cylinder control.



JOINT CLAMP CONNECTION

Page B28

The joint clamp connection combines two OSP-P cylinders of the same size into a compact unit with high performance.

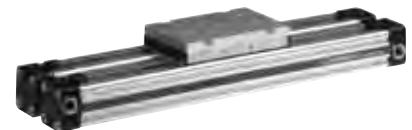

MULTIPLEX CONNECTION

Page B29

The multiplex connection combines two or more OSP-P cylinders of the same size into one unit.

The orientation of the carriers can be freely selected.



ACCESSORIES

MAGNETIC SWITCHES
TYPE RS, ES, RST, EST

Pages B102-B108

For electrical sensing of end and intermediate piston positions, also in EX-Areas.

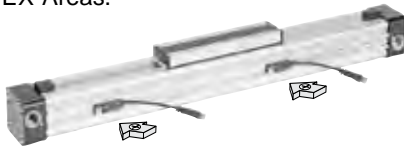

CLEVIS MOUNTING

Page B20-B21

Carrier with tolerance and parallelism compensation for driving loads supported by external linear guides.

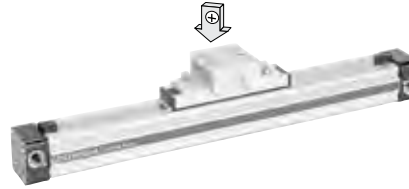

END CAP MOUNTING

Page B23

For end-mounting of the cylinder.

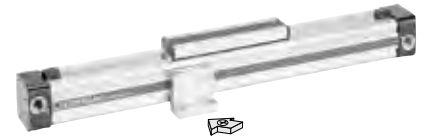

INVERSION MOUNTING

Page B22

The inversion mounting transfers the driving force to the opposite side, e. g. for dirty environments.



MID-SECTION SUPPORT

Page B24

For supporting long cylinders or mounting the cylinder by its dovetail rails.

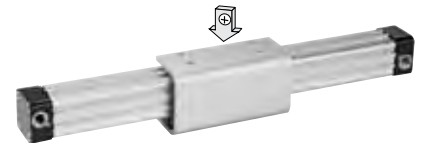

B

B

Characteristics		Pressures quoted as gauge pressure		
Characteristics	Symbol	Unit	Description	
General Features				
Type			Rodless cylinder	
Series			OSP-P	
System			Double-acting, with cushioning, position sensing capability	
Mounting			See drawings	
Air Connection			Threaded	
Ambient temperature range	T _{min} T _{max}	°C °C	-10 +80	Other temperature ranges on request
Weight (mass)		kg	See table below	
Installation			In any position	
Medium			Filtered, unlubricated compressed air (other media on request)	
Lubrication			Permanent grease lubrication (additional oil mist lubrication not required) Option: special slow speed grease	
Material	Cylinder Profile		Anodized aluminum	
	Carrier (piston)		Anodized aluminum	
	End caps		Aluminum, lacquered / Plastic (P10)	
	Sealing bands		Corrosion resistant steel	
	Seals		NBR (Option: Viton®)	
	Screws		Galvanized steel Option: stainless steel	
	Dust covers, wipers		Plastic	
Max. operating pressure	p _{max}	bar	8	

Weight (mass) kg		
Cylinder series (Basic cylinder)	Weight (Mass) kg	
	At 0 mm stroke	per 100 mm stroke
OSP-P10	0.087	0.052
OSP-P16	0.22	0.1
OSP-P25	0.65	0.197
OSP-P32	1.44	0.354
OSP-P40	1.95	0.415
OSP-P50	3.53	0.566
OSP-P63	6.41	0.925
OSP-P80	12.46	1.262

Size Comparison							
P10	P16	P25	P32	P40	P50	P63	P80

Rodless Pneumatic Cylinder

∅ 10-80 mm



Series OSP-P..

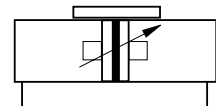

Standard Versions:

- Double-acting with adjustable end cushioning
- With magnetic piston for position sensing
- Long-Stroke Cylinders for stroke lengths up to 41 m (consult factory)

Special Versions:

- With special pneumatic cushioning system (on request)
- Clean room cylinders (see page B31-B34)
- Stainless steel screws
- Slow speed lubrication
- Viton® seals
- Both air connections on one end
- Air connection on the end-face
- Integrated Valves
- End cap can be rotated 4 x 90° to position air connection as desired
- Free choice of stroke length up to 6000 mm, Long-Stroke version (∅50-80mm) for stroke lengths up to 41 m



B

Loads, Forces and Moments

Choice of cylinder is decided by:

- Permissible loads, forces and moments
- Performance of the pneumatic end cushions. The main factors here are the mass to be cushioned and the piston speed at start of cushioning (unless external cushioning is used, e. g. hydraulic shock absorbers).

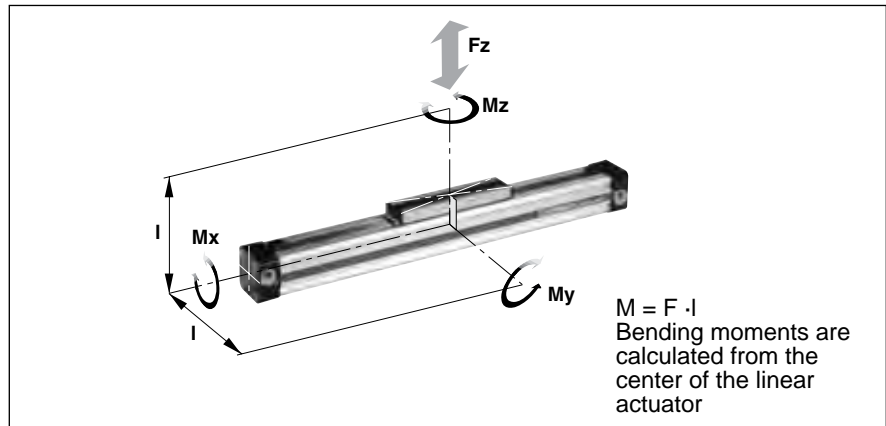

The adjacent table shows the maximum values for light, shock-free operation, which must not be exceeded even in dynamic operation. **Load and moment data are based on speeds $v \leq 0.5$ m/s.**

When working out the action force required, it is essential to take into account the friction forces generated by the specific application or load.

Cylinder Series (mm Ø)	Theoretical Action Force at 6 bar (N)	Effective Action Force F_A at 6 bar (N)	max. Moments			max. Load F (N)	Cushion Length (mm)
			Mx (Nm)	My (Nm)	Mz (Nm)		
OSP-P10	47	32	0.2	1	0.3	20	2.5 *
OSP-P16	120	78	0.45	4	0.5	120	11
OSP-P25	295	250	1.5	15	3	300	17
OSP-P32	483	420	3	30	5	450	20
OSP-P40	754	640	6	60	8	750	27
OSP-P50	1178	1000	10	115	15	1200	30
OSP-P63	1870	1550	12	200	24	1650	32
OSP-P80	3016	2600	24	360	48	2400	39

* A rubber element (non-adjustable) is used for end cushioning. To deform the rubber element enough to reach the absolute end position would require a Δp of 4 bar!

Cushioning Diagram

Work out your expected moving mass and read off the maximum permissible speed at start of cushioning.

Alternatively, take your desired speed and expected mass and find the cylinder size required.

Please note that piston speed at start of cushioning is typically ca. 50% higher than the average speed, and that it is this higher speed which determines the choice of cylinder. If these maximum permissible values are exceeded, additional shock absorbers must be used.

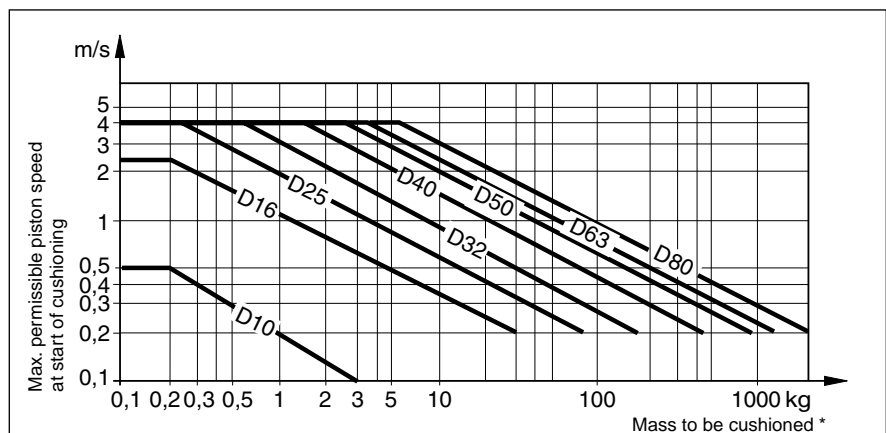

* For cylinders with linear guides or brakes, please be sure to take the mass of the carriage or the brake housing into account.

If the permitted limit values are exceeded, either additional shock absorbers should be fitted in the area of the center of gravity or you can consult us about our special cushioning system – we shall be happy to advise you on your specific application.

B

Permissible Support Spacings: OSP - P10 - P32

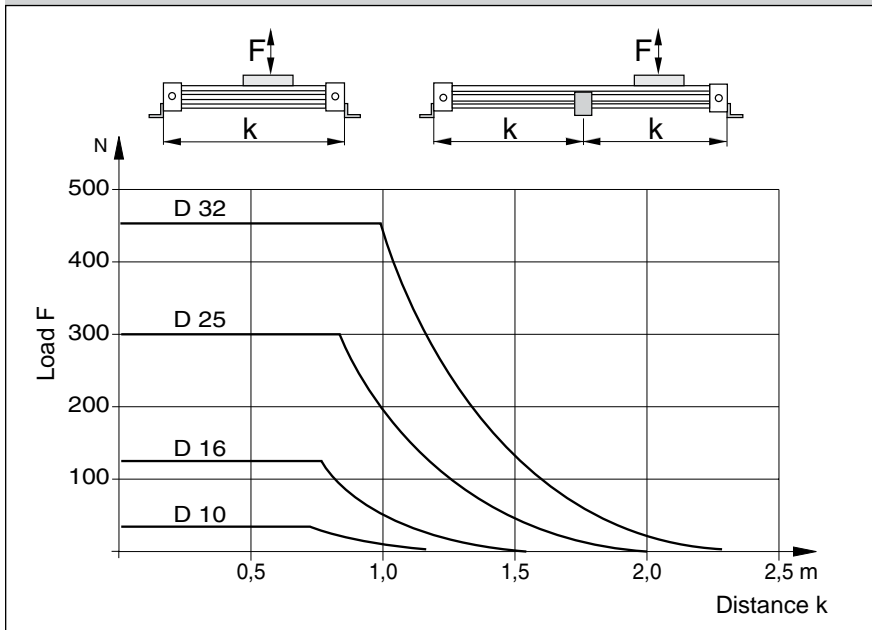

Mid-Section Supports

To avoid excessive bending and oscillation of the cylinder, mid-section supports are required dependent on specified stroke lengths and applied loads. The diagrams show the maximum possible support spacings depending on the load.

Bending up to max. 0.5 mm is permissible between supports. The mid-section supports are clamped on to the dovetail profile of the cylinder tube. They are also able to take the axial forces.

B

Permissible Support Spacings: OSP - P40 - P80

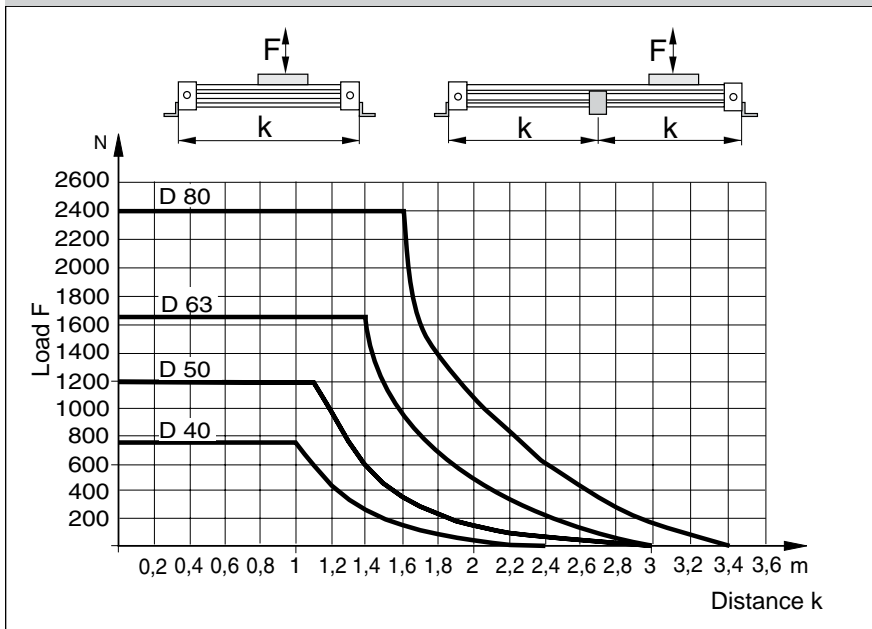

Dimensions

Cylinder Stroke and Dead Length A

- Free choice of stroke length up to 6000 mm in 1 mm steps.
- Longer strokes on request.

B

Tandem Cylinder

Two pistons are fitted: dimension "Z" is optional. (Please note minimum distance "Zmin").

- Free choice of stroke length up to 6000 mm in 1 mm steps.
- Longer strokes on request.
- **Stroke length to order is stroke + dimension "Z"**

Please note:

To avoid multiple actuation of magnetic switches, the second piston is not equipped with magnets.

Dimensions of Basic Cylinder OSP-P10

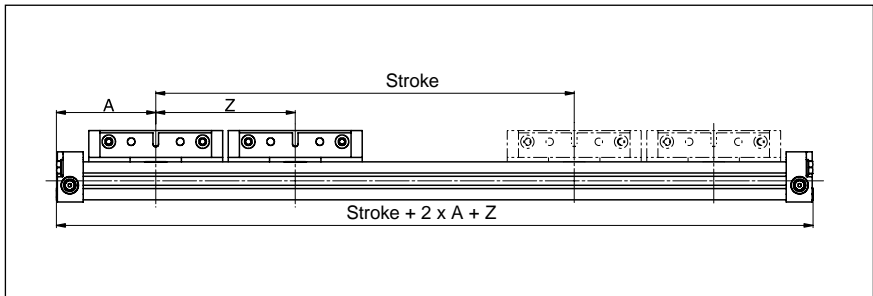
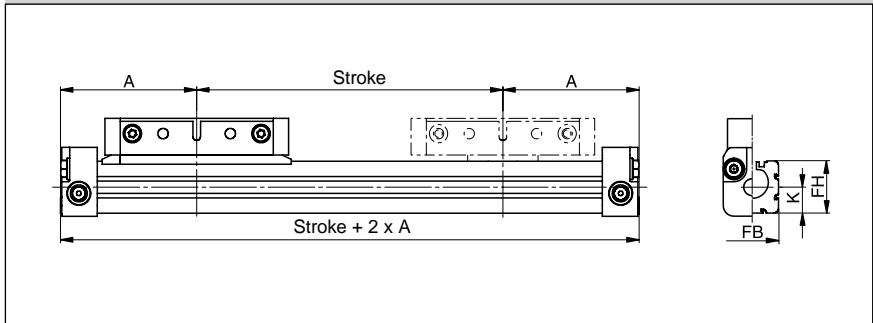

End Cap/Air Connection Series OSP-P10

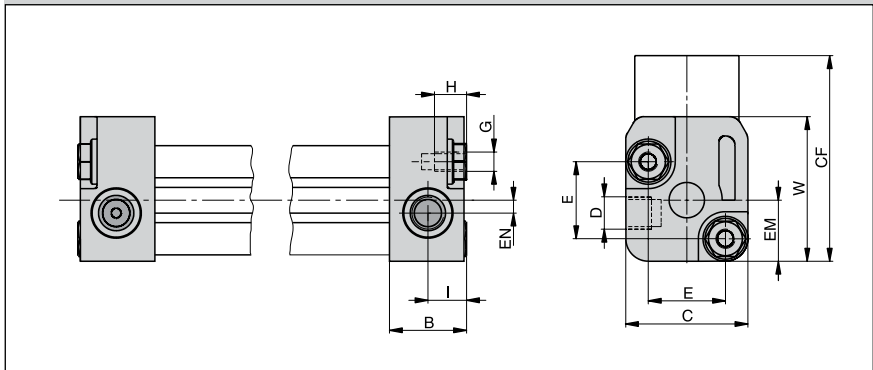

Carrier Series OSP-P10

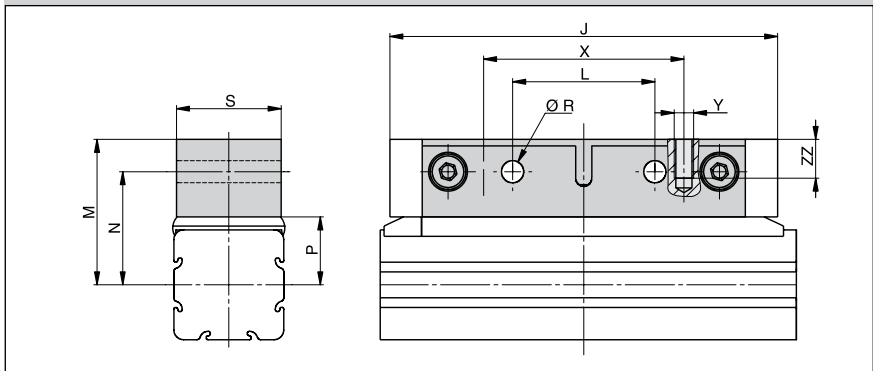

Dimension Table (mm)

Cylinder Series	A	B	C	D	E	G	H	I	J	K	L	M	N	P	R	S	W	X	Y	Z _{min}	CF	EM	EN	FB	FH	ZZ
OSP-P10	44.5	12	19	M5	12	M3	5	6	60	8.5	22	22.5	17.5	10.5	3.4	16	22.5	31	M3	64	32	9.5	2	17	17	6



Dimensions

Dimensions of Basic Cylinder OSP - P16-P80

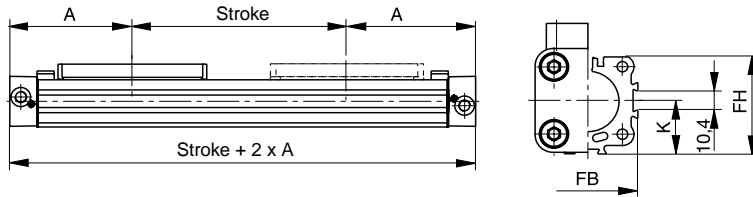

Cylinder Stroke and Dead Length A

- Free choice of stroke length up to 6000 mm in 1 mm steps.
- Longer strokes on request.

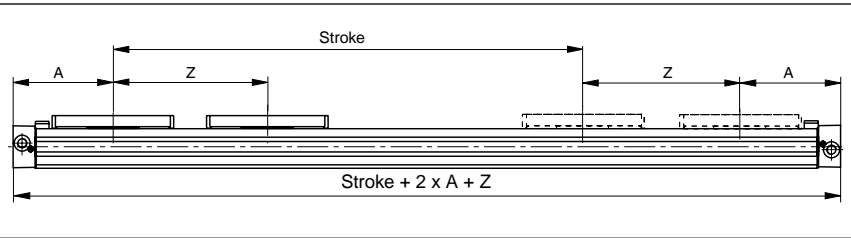

Tandem Cylinder

Two pistons are fitted: dimension "Z" is optional. (Please note minimum distance "Zmin").

- Free choice of stroke length up to 6000 mm in 1 mm steps.
- Longer strokes on request.
- **Stroke length to order is stroke + dimension "Z"**

End Cap/Air Connection can be rotated 4 x 90° Series OSP-P16 to P32

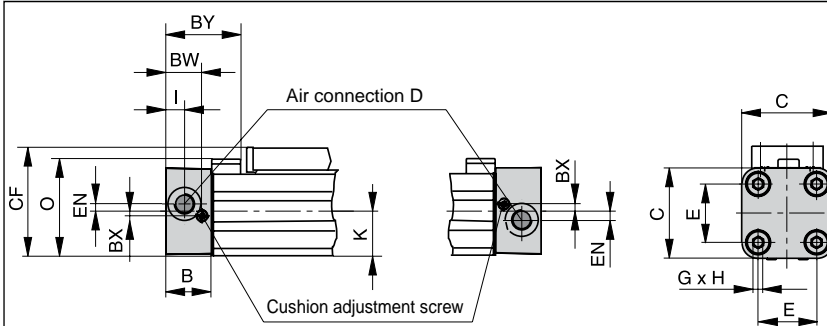

Please note:

To avoid multiple actuation of magnetic switches, the second piston is not equipped with magnets.

End Cap/Air Connection can be rotated 4 x 90° Series OSP-P40 to P80

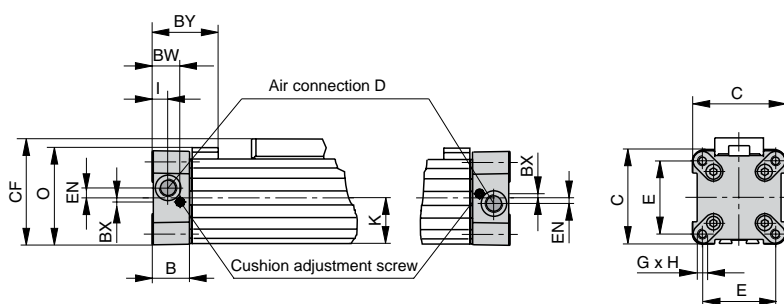

Carrier Series OSP-P16 to P80

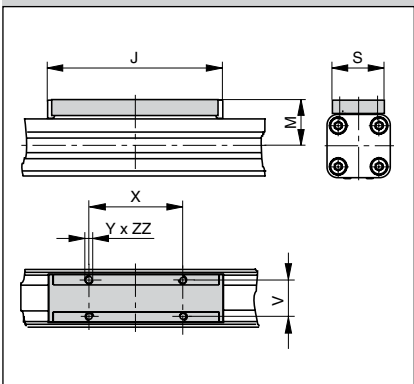

Dimension Table (mm)

Cylinder Series	A	B	C	D	E	G	H	I	J	K	M	O	S	V	X	Y	Z	BW	BX	BY	CF	EN	FB	FH	ZZ
OSP-P16	65	14	30	M5	18	M3	9	5.5	69	15	23	33.2	22	16.5	36	M4	81	10.8	1.8	28.4	38	3	30	27.2	7
OSP-P25	100	22	41	G1/8	27	M5	15	9	117	21.5	31	47	33	25	65	M5	128	17.5	2.2	40	52.5	3.6	40	39.5	8
OSP-P32	125	25.5	52	G1/4	36	M6	15	11.5	152	28.5	38	59	36	27	90	M6	170	20.5	2.5	44	66.5	5.5	52	51.7	1
OSP-P40	150	28	69	G1/4	54	M6	15	12	152	34	44	72	36	27	90	M6	212	21	3	54	78.5	7.5	62	63	10
OSP-P50	175	33	87	G1/4	70	M6	15	14.5	200	43	49	86	36	27	110	M6	251	27	-	59	92.5	11	76	77	10
OSP-P63	215	38	106	G3/8	78	M8	21	14.5	256	54	63	107	50	34	140	M8	313	30	-	64	117	12	96	96	16
OSP-P80	260	47	132	G1/2	96	M10	25	22	348	67	80	133	52	36	190	M10	384	37.5	-	73	147	16.5	122	122	20



Air Connection on the End-Face #5

In some situations it is necessary or desirable to fit a special end cap with the air connection on the end-face instead of the standard end cap with the air connection on the side. The special end cap can also be rotated 4 x 90° to locate the cushion adjustment screw as desired. Supplied in pairs.

B

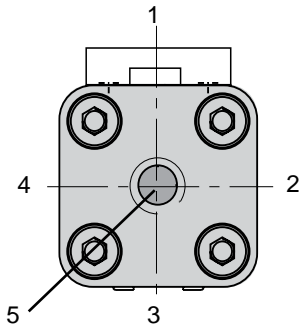

Note: Position #2 is the standard location.

Series OSP-P16 to P32

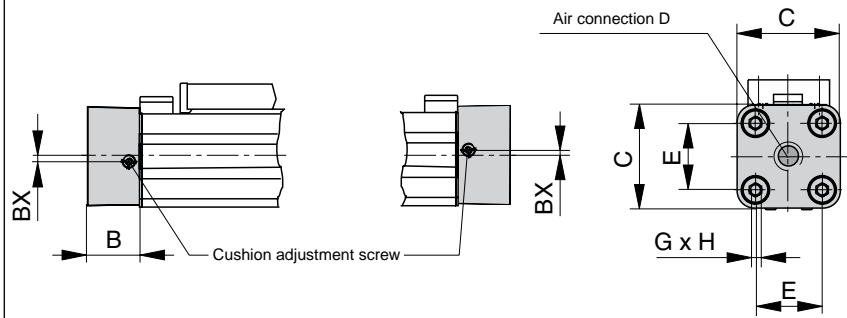

Series OSP-P40 to P80

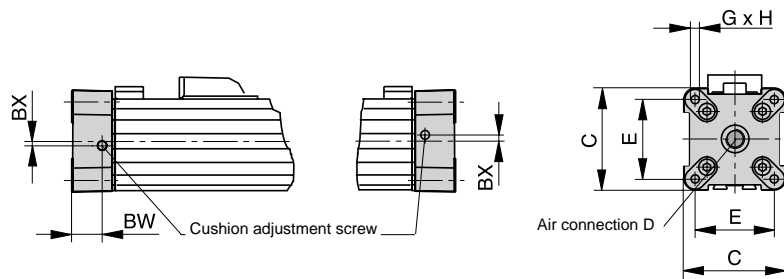

Dimension Table (mm)

Cylinder Series	B	C	D	E	G	H	BX	BW
OSP-P16	14	30	M5	18	M3	9	1.8	10.8
OSP-P25	22	41	G1/8	27	M5	15	2.2	17.5
OSP-P32	25.5	52	G1/4	36	M6	15	2.5	20.5
OSP-P40	28	69	G1/4	54	M6	15	3	21
OSP-P50	33	87	G1/4	70	M6	15	–	27
OSP-P63	38	106	G3/8	78	M8	21	–	30
OSP-P80	47	132	G1/2	96	M10	25	–	37.5

Series OSP-P16

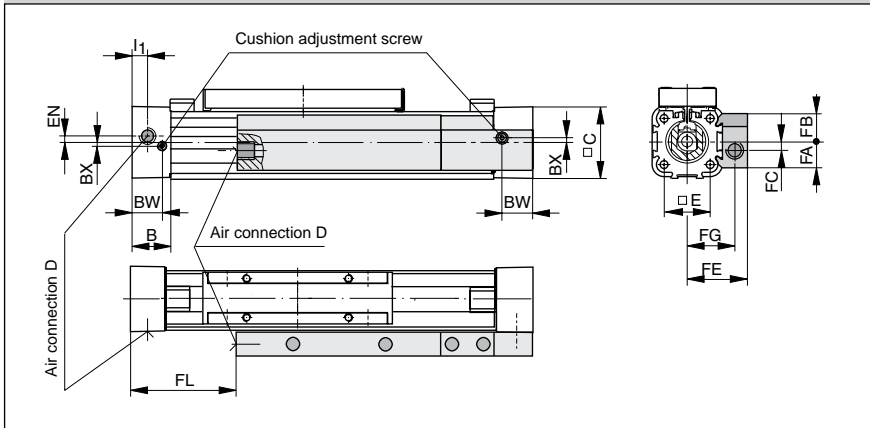

Single End Porting

A special end cap with both air connections on one side is available for situations where shortage of space, simplicity of installation or the nature of the process make it desirable. Air supply to the other end is via internal air passages (OSP-P25 to P80) or via a hollow aluminum profile fitted externally (OSP-P16). **In this case the end caps cannot be rotated.**

Series OSP-P25

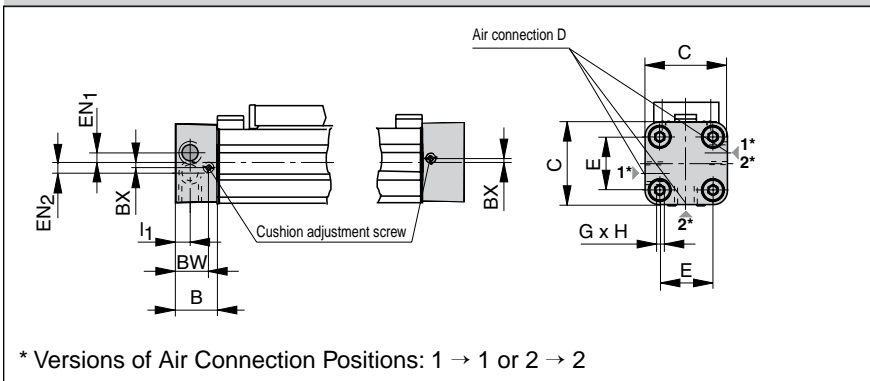

* Versions of Air Connection Positions: 1 → 1 or 2 → 2



Please note:
When combining the OSP-P16 single end porting with inversion mountings, RS magnetic switches can only be mounted directly opposite to the external air-supply profile.

Series OSP-P32 to P80

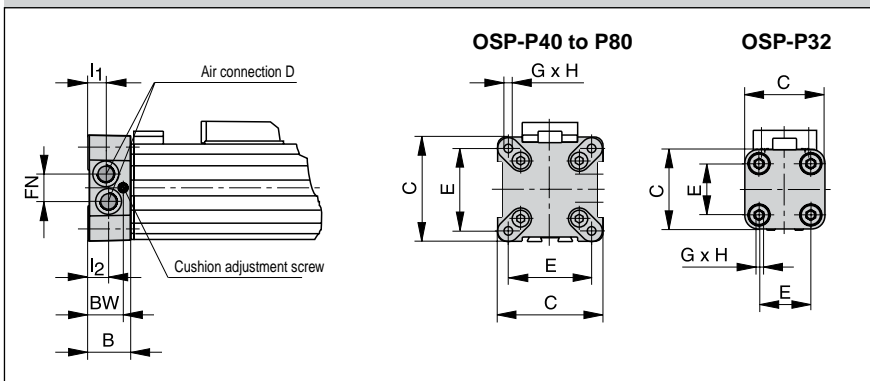

Dimension Table (mm)

Cylinder Series	B	C	D	E	G	H	I ₁	I ₂	BX	BW	EN	EN ₁	EN ₂	FA	FB	FC	FE	FG	FL	FN
OSP-P16	14	30	M5	18	M3	9	5.5	-	1.8	10.8	3	-	-	12.6	12.6	4	27	21	36	-
OSP-P25	22	41	G1/8	27	M5	15	9	-	2.2	17.5	-	3.6	3.9	-	-	-	-	-	-	-
OSP-P32	25.5	52	G1/8	36	M6	15	12.2	10.5	-	20.5	-	-	-	-	-	-	-	-	-	15.2
OSP-P40	28	69	G1/8	54	M6	15	12	12	-	21	-	-	-	-	-	-	-	-	-	17
OSP-P50	33	87	G1/4	70	M6	15	14.5	14.5	-	27	-	-	-	-	-	-	-	-	-	22
OSP-P63	38	106	G3/8	78	M8	21	16.5	13.5	-	30	-	-	-	-	-	-	-	-	-	25
OSP-P80	47	132	G1/2	96	M10	25	22	17	-	37.5	-	-	-	-	-	-	-	-	-	34.5



Dimensions

Integrated 3/2 Way Valves VOE

For optimal control of the OSP-P cylinder, 3/2 way valves integrated into the cylinder's end caps can be used as a compact and complete solution. They allow for easy positioning of the cylinder, smooth operation at the lowest speeds and fast response, making them ideally suited for the direct control of production and automation processes.

Integrated 3/2 Way Valves VOE Series OSP-P25, P32, P40 and P50



Characteristics 3/2Way Valves VOE

Characteristics:

- Complete compact solution
- Various connection possibilities:
 Free choice of air connection with rotating end caps with VOE valves,
 Air connection can be rotated 4 x 90°,
 Solenoid can be rotated 4 x 90°,
 Pilot Valve can be rotated 180°
- High piston velocities can be achieved with max. 3 exhaust ports
- Minimal installation requirements
- Requires just one air connection per valve
- Optimal control of the OSP-P cylinder
- Excellent positioning characteristics
- Integrated operation indicator
- Integrated exhaust throttle valve
- Manual override - indexed
- Adjustable end cushioning
- Easily retrofitted – please note the increase in the overall length of the cylinder!

Characteristics	3/2 Way Valves with spring return			
Pneumatic diagram				
Type	VOE-25	VOE-32	VOE-40	VOE-50
Actuation	electrical			
Basic position	P → A open, R closed			
Type	Poppet valve, non overlapping			
Mounting	integrated in end cap			
Installation	in any position			
Port size	G 1/8	G 1/4	G 3/8	G 3/8
Temperature	-10°C to +50°C *			
Operating pressure	2-8 bar			
Nominal voltage	24 V DC / 230 V AC, 50 Hz			
Power consumption	2,5 W / 6 VA			
Duty cycle	100%			
Electrical Protection	IP 65 DIN 40050			

* other temperature ranges on request

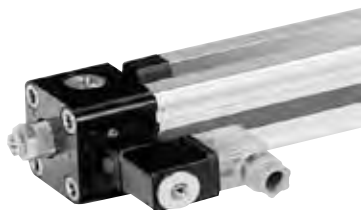

B

B

Dimensions VOE Valves OSP-P25 and P32

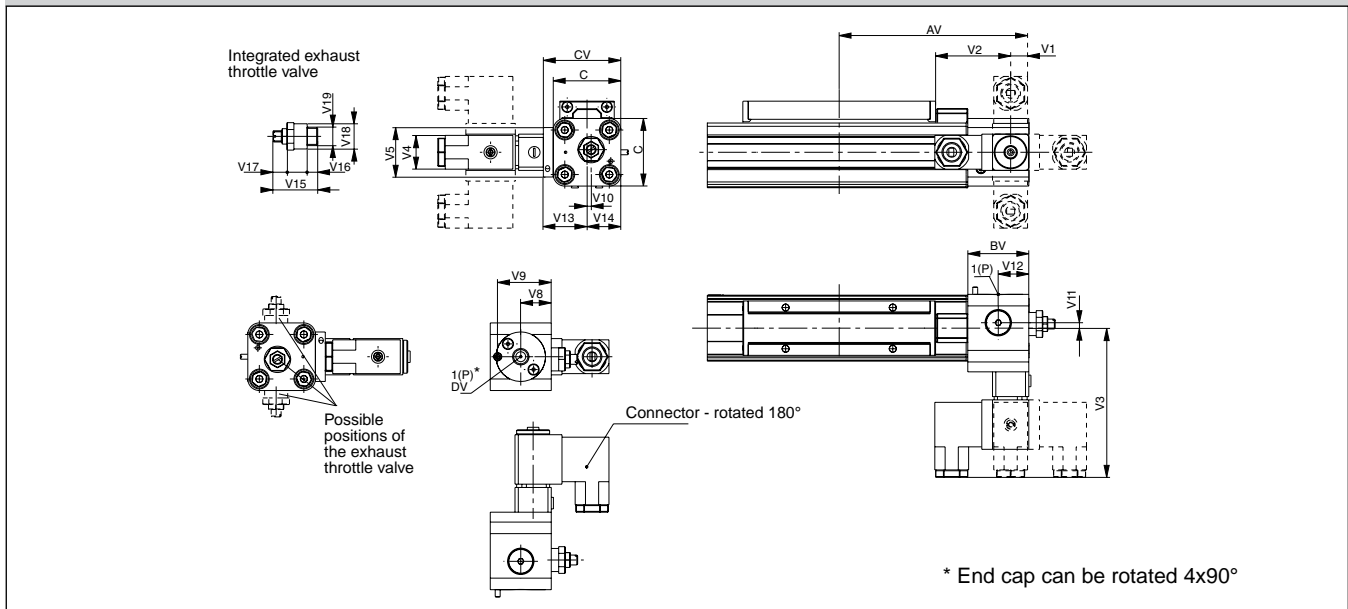

Dimension Table (mm)

Cylinder Series	AV	BV	C	CV	DV	V1	V2	V3	V4	V5	V8	V9	V10	V11	V12	V13	V14	V15	V16	V17	V18	V19
OSP-P25	115	37	41	47	G1/8	11	46	90.5	22	30	18.5	32.5	2.5	3.3	18.5	26.5	20.5	24	5	4	14	G1/8
OSP-P32	139	39.5	52	58	G1/4	20.5	46	96	22	32	20.5	34.7	6	5	20.5	32	26	32	7.5	6	18	G1/4

Dimensions VOE Valves OSP-P40 and P50

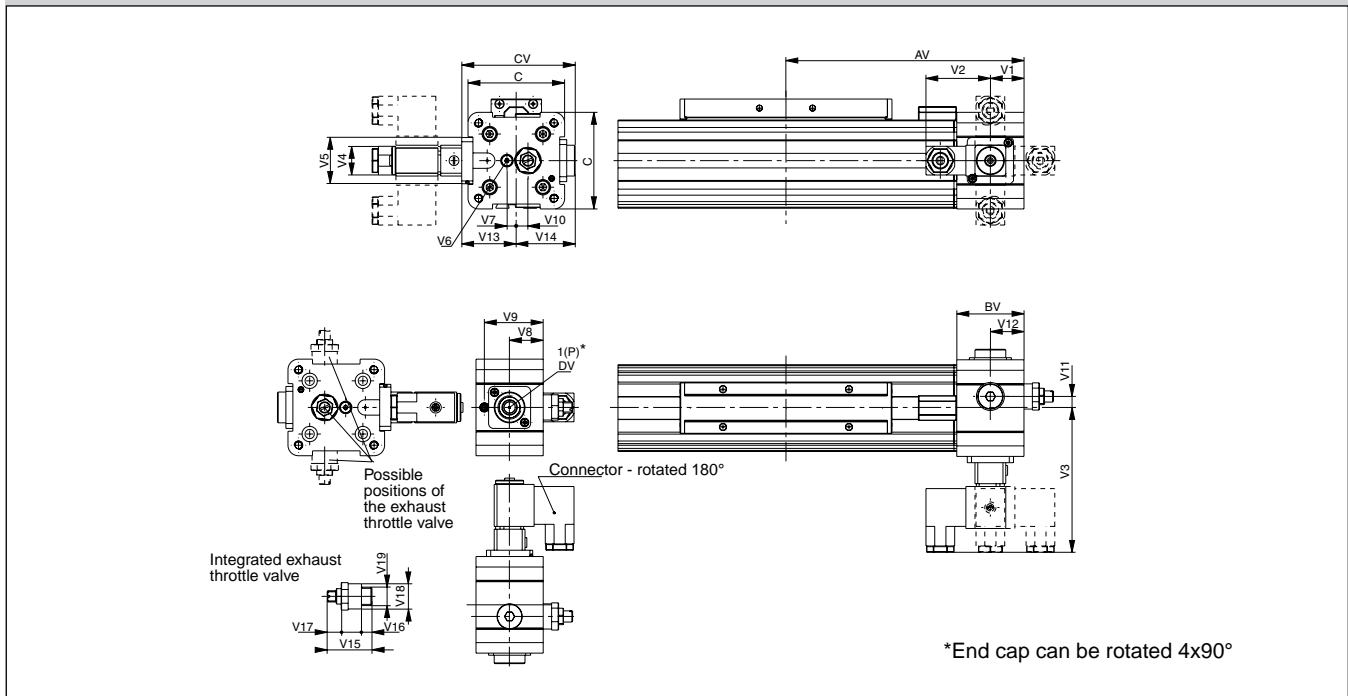

Dimension Table (mm)

Cylinder Series	AV	BV	C	CV	DV	V1	V2	V3	V4	V5	V6	V7	V8	V9	V10	V11	V12	V13	V14	V15	V16	V17	V18	V19
OSP-P40	170	48	69	81	G3/8	24	46	103	22	33	M5	6.7	24	42	8.3	8.3	24	39	42	32	7.5	6	18	G1/4
OSP-P50	190	48	87	82	G3/8	24	46	102	22	33	M5	4.5	24	42	12.2	12.2	24	38	44	32	7.5	6	18	G1/4

Active Brake



**Series AB 25 to 80
 for linear drive
 • Series OSP-P**

B

Features:

- Actuated by pressurization
- Released by spring actuation
- Completely stainless version
- Holds position, even under changing load conditions

For further technical data, please refer to the data sheets for linear drives OSP-P (page B7)

Note:

For combinations Active Brake AB + SFI-plus + Magnetic Switch contact our technical department please.

Function

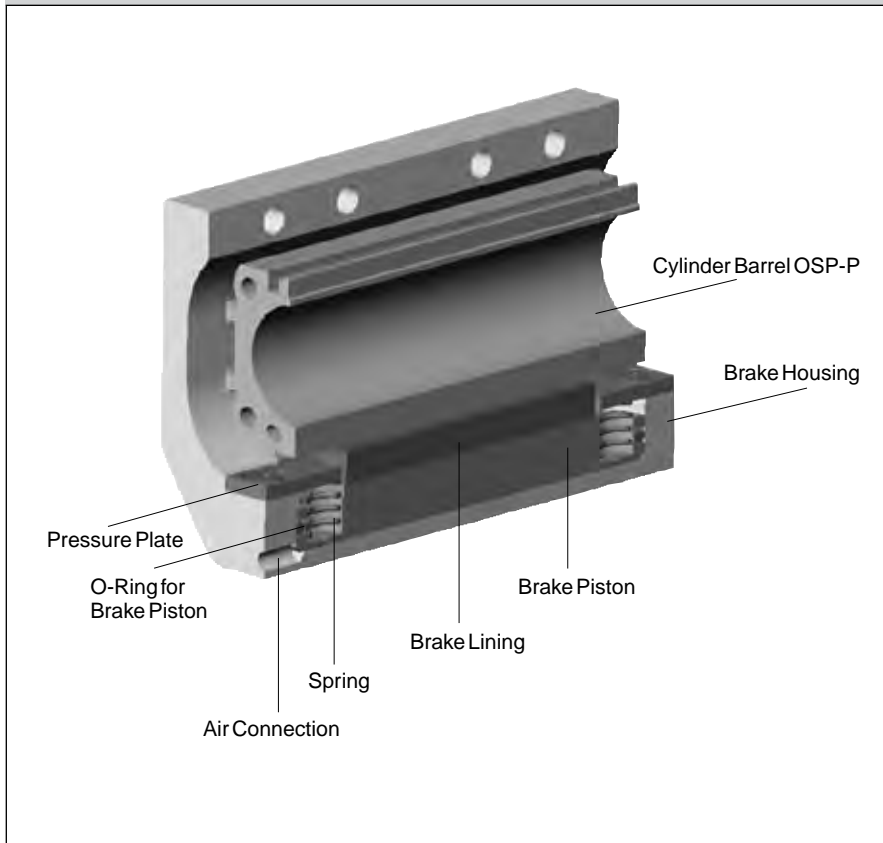

Forces and Weights

Series	For linear drive	Max. braking force (N) ⁽¹⁾	Brake pad way (mm)	Mass (kg)		Order No. Active brake	
				Linear drive with brake 0 mm stroke	increase per 100mm stroke brake*		
AB 25	OSP-P25	350	2.5	1.0	0.197	0.35	20806
AB 32	OSP-P32	590	2.5	2.02	0.354	0.58	20807
AB 40	OSP-P40	900	2.5	2.83	0.415	0.88	20808
AB 50	OSP-P50	1400	2.5	5.03	0.566	1.50	20809
AB 63	OSP-P63	2170	3.0	9.45	0.925	3.04	20810
AB 80	OSP-P80	4000	3.0	18.28	1.262	5.82	20811

⁽¹⁾ – at 6 bar
 both chambers pressurized with 6 bar
 Braking surface dry
 – oil on the braking surface will reduce the braking force

*** Please Note:**
 The mass of the brake has to be added to the total moving mass when using the cushioning diagram.



B

Series OSP-P25 and P32 with Active Brake AB

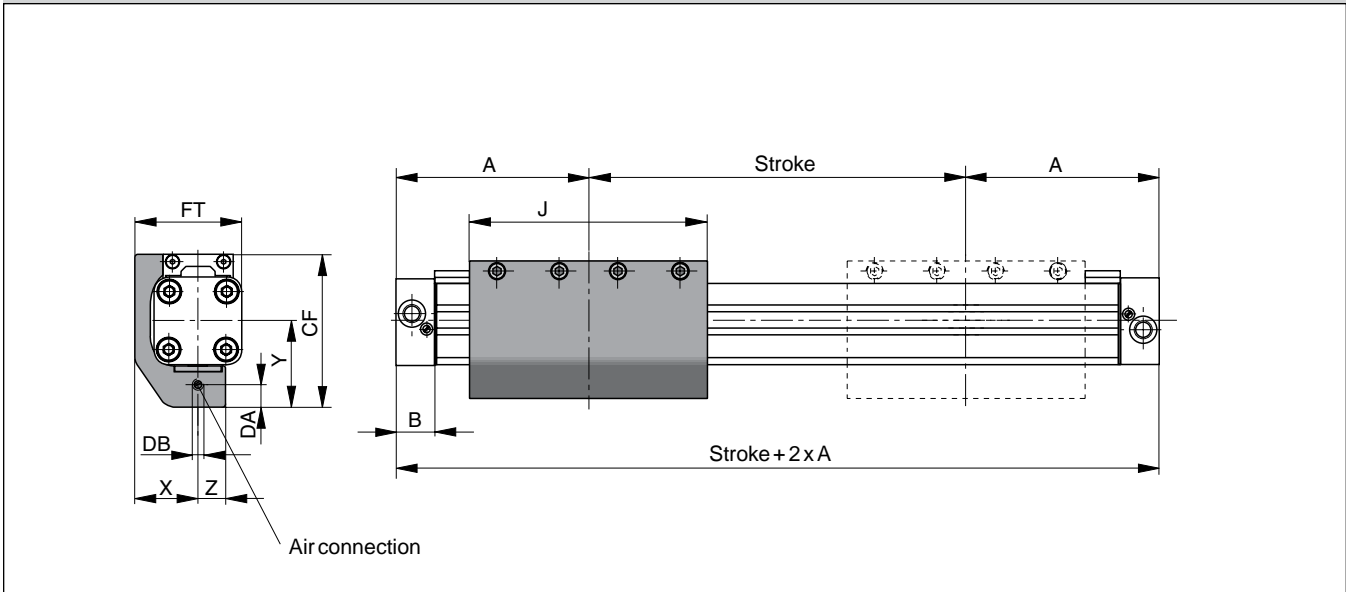

Series OSP-P40, P50, P63, P80 with Active Brake AB

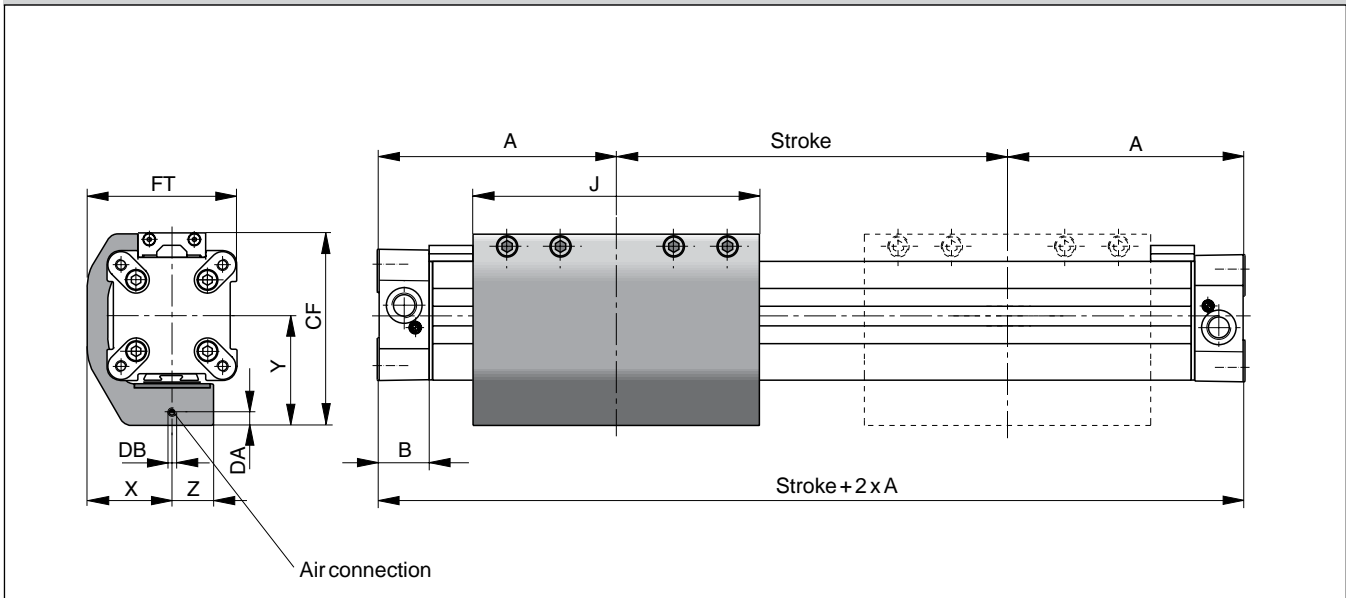

Dimension Table (mm)

Series	A	B	J	X	Y	Z	CF	DA	DB	FT
AB 25	100	22	117	29.5	43	13	74	4	M5	50
AB 32	125	25.5	151.4	36	50	15	88	4	M5	62
AB 40	150	28	151.4	45	58	22	102	7	M5	79.5
AB 50	175	33	200	54	69.5	23	118.5	7.5	M5	97.5
AB 63	215	38	256	67	88	28	151	9	G1/8	120
AB 80	260	47	348	83	105	32	185	10	G1/8	149

Dimensions

End Cap Mountings

On the end-face of each cylinder end cap there are four threaded holes for mounting the cylinder. The hole layout is square, so that the mounting can be fitted to the bottom, top or either side.

Series OSP – P25 and P32 with Active Brake AB:Type A3

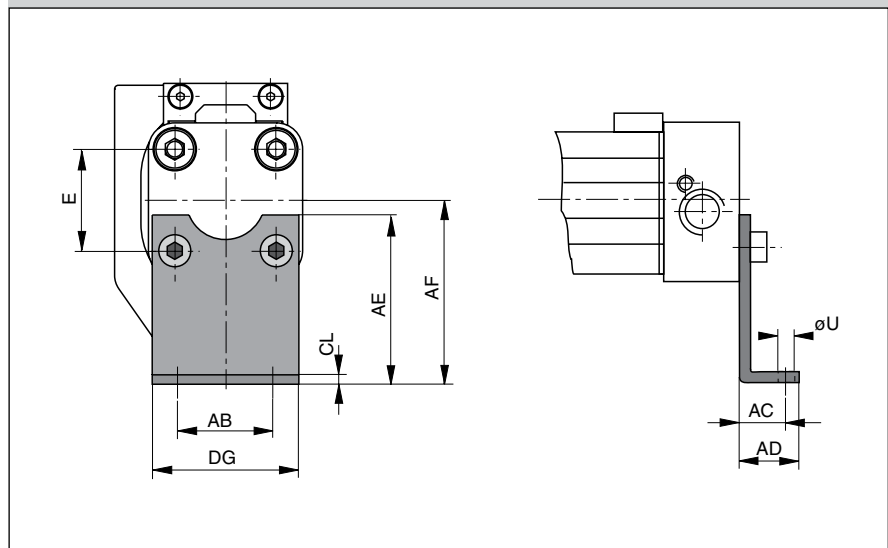

Series OSP – P40, P50, P63, P80 with Active Brake AB:Type C3

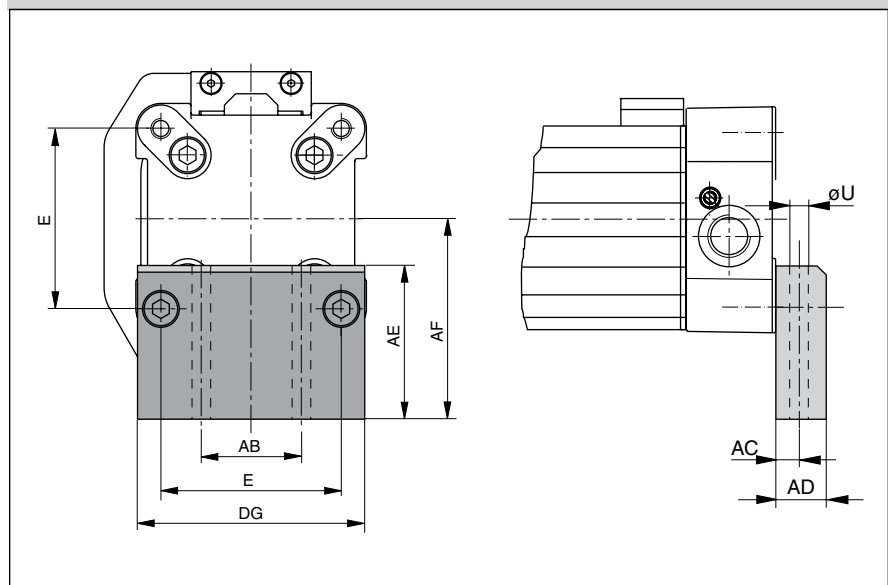

B

Material:

Series OSP-P25, P32:
Galvanized steel

The mountings are supplied in pairs.



Material:

Series OSP-P40, P50, P63, P80:
Anodized aluminum

The mountings are supplied in pairs.
Stainless steel version on request.



Dimension Table (mm)

Series	E	øU	AB	AC	AD	AE	AF	CL	DG	Order No.	
										Type A3	Type C3
AB 25	27	5.8	27	16	22	45	49	2.5	39	2060	–
AB 32	36	6.6	36	18	26	42	52	3	50	3060	–
AB 40	54	9	30	12.5	24	46	60	–	68	–	20339
AB 50	70	9	40	12.5	24	54	72	–	86	–	20350
AB 63	78	11	48	15	30	76	93	–	104	–	20821
AB 80	96	14	60	17.5	35	88	110	–	130	–	20822

Mid-Section Supports

Mid-Section Support

Mid-section supports are required from a certain stroke length to prevent excessive deflection and vibration of the linear drive.

The diagrams show the maximum permissible unsupported length in relation to loading. Deflection of 0.5 mm max. between supports is permissible.

The Mid-Section supports are attached to the dovetail rails, and can take axial loads.

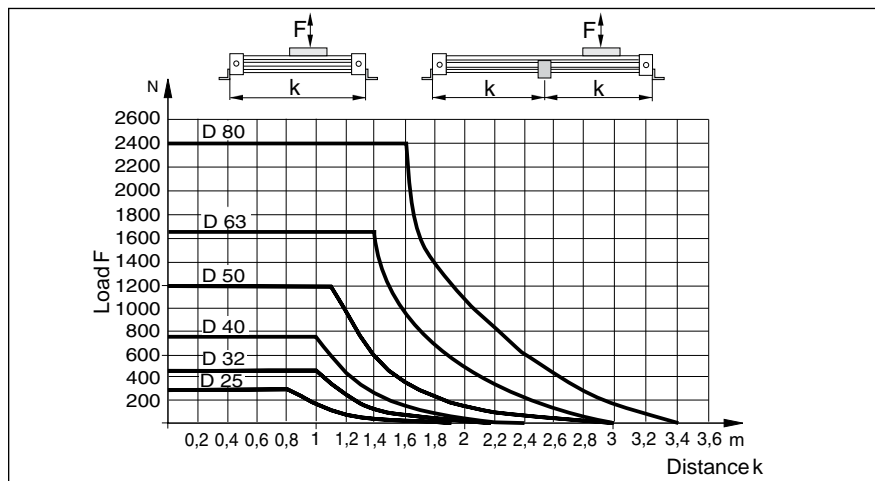

Mid-Section Supports

Note to Type E3:

Mid-Section supports can only be mounted opposite of the brake housing.

Stainless steel version available on request.

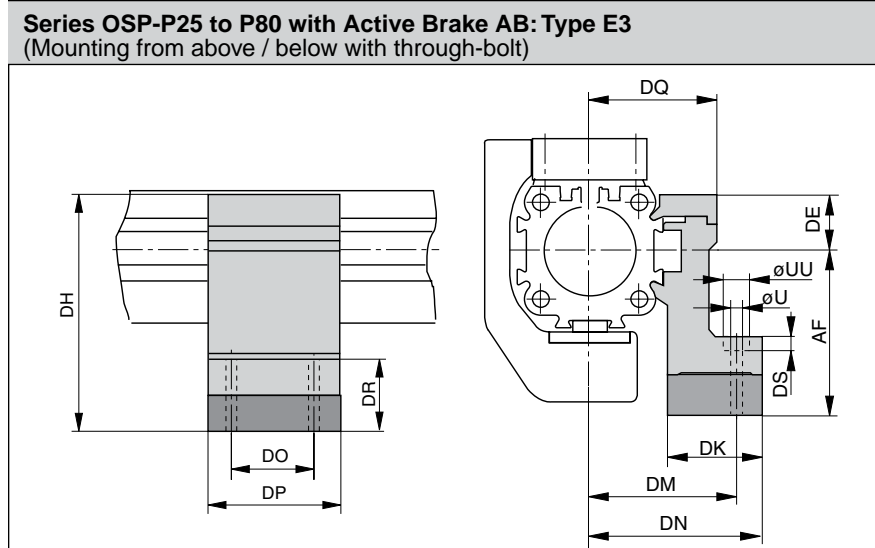

Dimension Table (mm)

Series	U	UU	AF	DE	DH	DK	DM	DN	DO	DP	DQ	DR	DS	Order No. Type E3
AB 25	5.5	10	49	16	65	26	40	47.5	36	50	34.5	35	5.7	20353
AB 32	5.5	10	52	16	68	27	46	54.5	36	50	40.5	32	5.7	20356
AB 40	7	–	60	23	83	34	53	60	45	60	45	32	–	20359
AB 50	7	–	72	23	95	34	59	67	45	60	52	31	–	20362
AB 63	9	–	93	34	127	44	73	83	45	65	63	48	–	20453
AB 80	11	–	110	39.5	149.5	63	97	112	55	80	81	53	–	20819

Accessories for linear drives with Active Brakes – please order separately

Description	For detailed information, see page no.
Clevis mounting	B21
Adaptor profile	B25
T-groove profile	B26
Connection profile	B27
Magnetic switch (can only be mounted opposite of the brake housing)	B102-B108
Incremental displacement measuring system SFI-plus	B113-B115

Linear Drive Accessories

ø 10 mm

Clevis Mounting

B



For Linear-drive
 • Series OSP-P

When external guides are used, parallelism deviations can lead to mechanical strain on the piston. This can be avoided by the use of a clevis mounting.

In the drive direction, the mounting has very little play.

Freedom of movement is provided as follows:

- Tilting in direction of movement
- Vertical compensation
- Tilting sideways
- Horizontal compensation

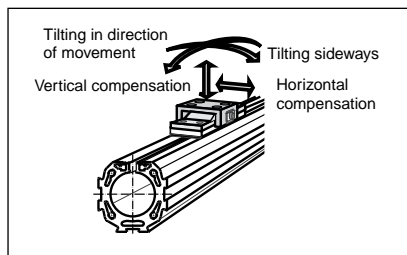
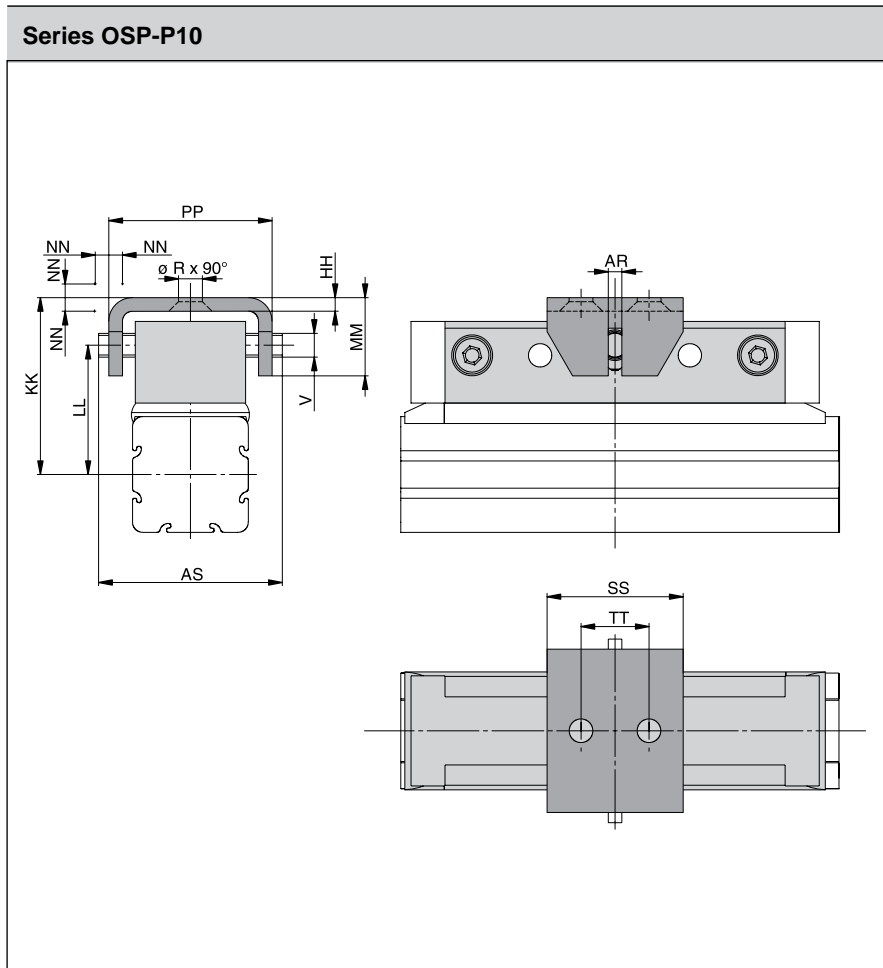

Dimension Table (mm)													Order No.	
Series	øR	V	AR	AS	HH	KK	LL	MM	NN*	PP	SS	TT	Standard	Stainless
OSP-P10	3.4	3.5	2	27	2	26	19	11.5	1	24	20	10	20971	-

* Dimension NN gives the possible plus and minus play in horizontal and vertical movement, which also makes tilting sideways possible.



Clevis Mountings

Series OSP-P16 to 32

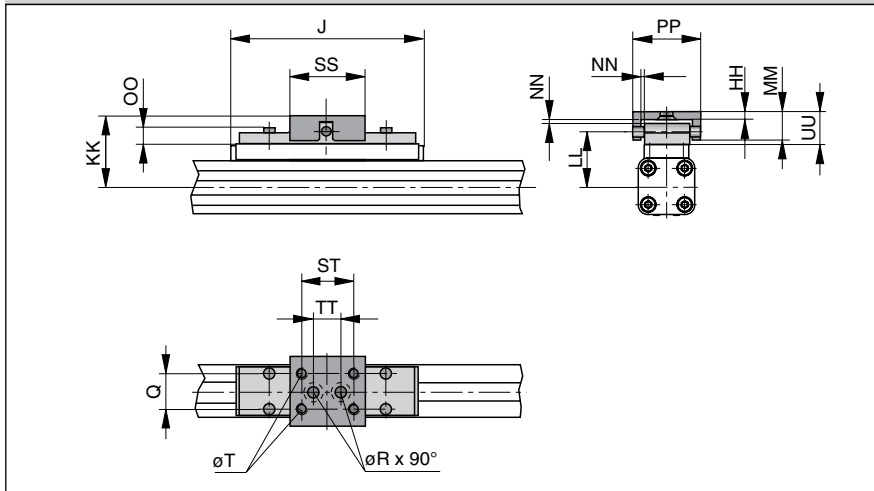

Series OSP-P40 to 80

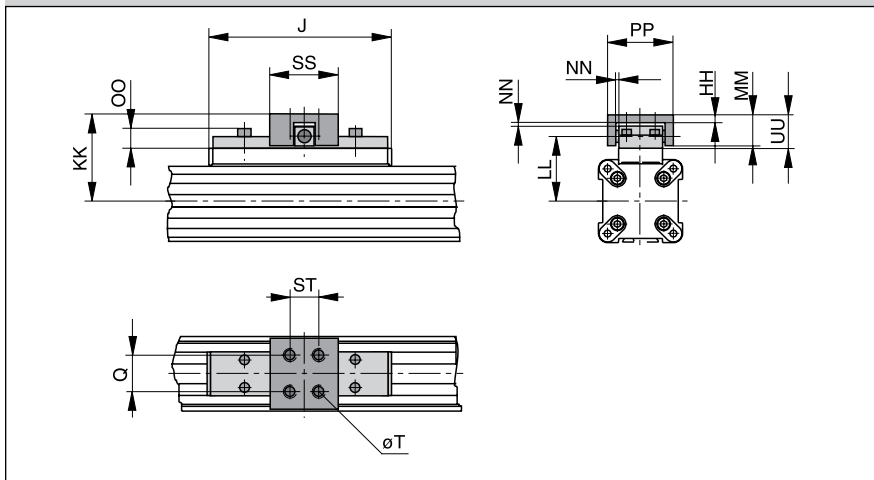

Please note:
When using additional inversion mountings, take into account the dimensions in page B22.

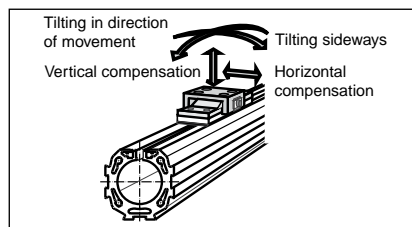

Linear Drive Accessories

ø 16-80 mm
Clevis Mounting



For Linear-drive
• Series OSP-P

When external guides are used, parallelism deviations can lead to mechanical strain on the piston. This can be avoided by the use of a clevis mounting.

In the drive direction, the mounting has very little play.

Freedom of movement is provided as follows:

- Tilting in direction of movement
- Vertical compensation
- Tilting sideways
- Horizontal compensation

A stainless steel version is also available.



Dimension Table (mm)

Series	J	Q	T	øR	HH	KK	LL	MM	NN*	OO	PP	SS	ST	TT	UU	Order No.	
																Standard	Stainless
OSP-P16	69	10	M4	4.5	3	34	26.6	10	1	8.5	26	28	20	10	11	20462	20463
OSP-P25	117	16	M5	5.5	3.5	52	39	19	2	9	38	40	30	16	21	20005	20092
OSP-P32	152	25	M6	6.6	6	68	50	28	2	13	62	60	46	40	30	20096	20094
OSP-P40	152	25	M6	—	6	74	56	28	2	13	62	60	46	—	30	20024	20093
OSP-P50	200	25	M6	—	6	79	61	28	2	13	62	60	46	—	30	20097	20095
OSP-P63	256	37	M8	—	8	100	76	34	3	17	80	80	65	—	37	20466	20467
OSP-P80	348	38	M10	—	8	122	96	42	3	16	88	90	70	—	42	20477	20478

* Dimension NN gives the possible plus and minus play in horizontal and vertical movement, which also makes tilting sideways possible.



Linear Drive Accessories

∅ 16-80 mm

Inversion Mounting

B



For Linear-drive
 • Series OSP-P

In dirty environments, or where there are special space problems, inversion of the cylinder is recommended.

The inversion bracket transfers the driving force to the opposite side of the cylinder. The size and position of the mounting holes are the same as on the standard cylinder.

Stainless steel version on demand.

Please note:

Other components of the OSP system such as **mid-section supports**, **magnetic switches** and the **external air passage for the P16**, can still be mounted on the free side of the cylinder.

When combining single end porting with inversion mountings, RS magnetic switches can only be mounted directly opposite to the external air-supply profile.

Important Note:

May be used in combination with Clevis Mounting, ref. dimensions in pages B20-B21.



Series OSP-P16 to 32

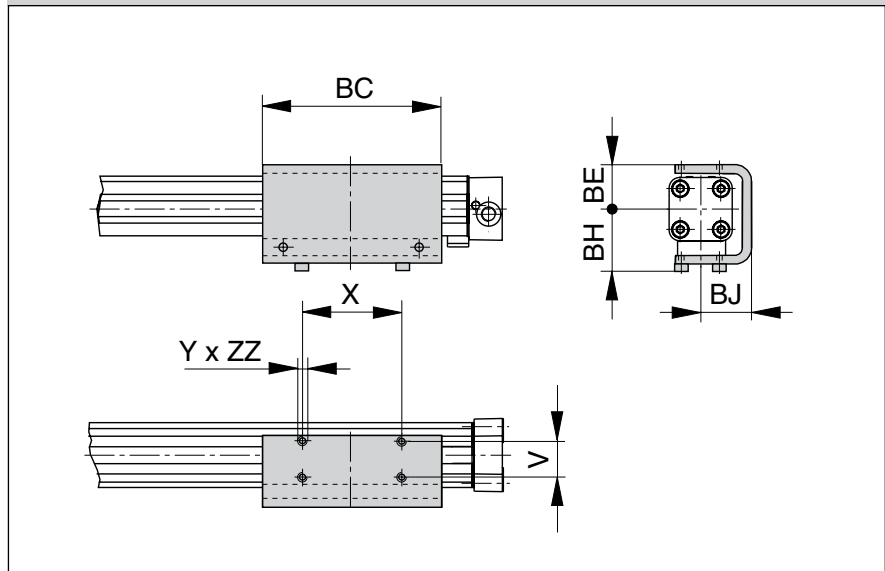

Series OSP-P40 to 80

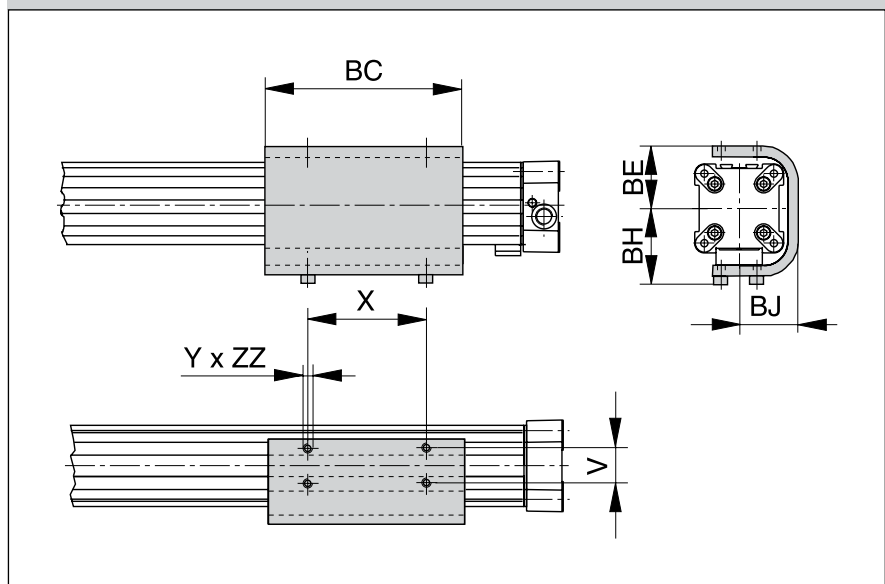

Dimension Table (mm)

Series	V	X	Y	BC	BE	BH	BJ	ZZ	Order No.
OSP-P16	16.5	36	M4	69	23	33	25	4	20446
OSP-P25	25	65	M5	117	31	44	33.5	6	20037
OSP-P32	27	90	M6	150	38	52	39.5	6	20161
OSP-P40	27	90	M6	150	46	60	45	8	20039
OSP-P50	27	110	M6	200	55	65	52	8	20166
OSP-P63	34	140	M8	255	68	83.5	64	10	20459
OSP-P80	36	190	M10	347	88	107.5	82	15	20490

Series OSP-P10: Type A1

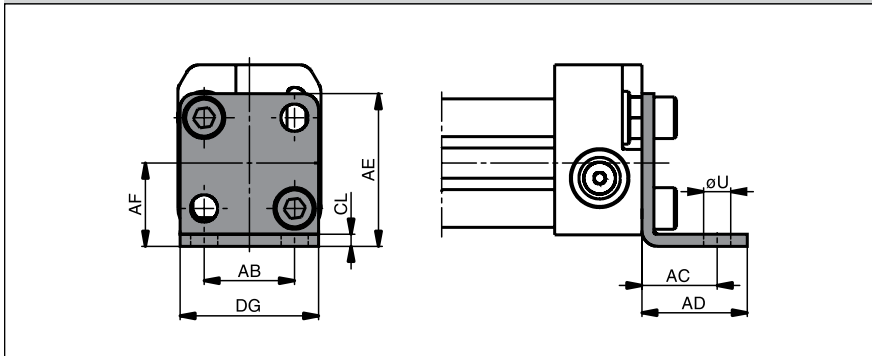

Series OSP-P16 to 32: Type A1

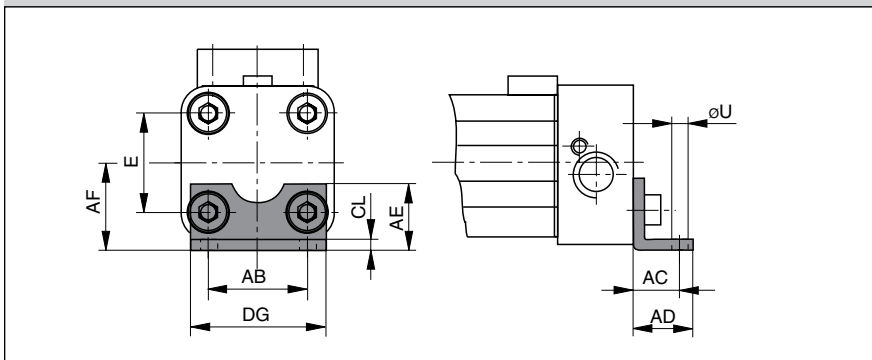

Series OSP-P40 to 80: Type C1

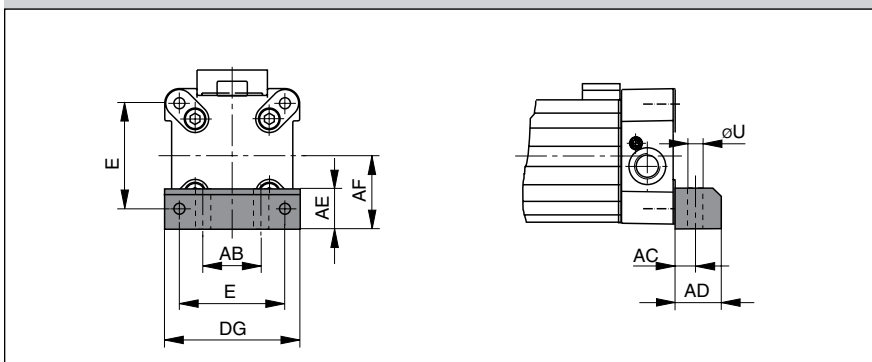

Linear Drive Accessories

ø 10-80 mm

End Cap Mountings



B

For Linear-drive
• Series OSP-P

On the end-face of each end cap there are four threaded holes for mounting the actuator.

The hole layout is square, so that the mounting can be fitted to the bottom, top or either side, regardless of the position chosen for the air connection.

Material:

Series OSP-P10 – P32:

Galvanized steel.

Series OSP-P40 – P80:

Anodized aluminum.

The mountings are supplied in pairs.



Dimension Table (mm)

Series	E	øU	AB	AC	AD	AE	AF	CL	DG	Order No. (*	
										Type A1	Type C1
OSP-P10	-	3.6	12	10	14	20.2	11	1.6	18.4	0240	-
OSP-P16	18	3.6	18	10	14	12.5	15	1.6	26	20408	-
OSP-P25	27	5.8	27	16	22	18	22	2.5	39	2010	-
OSP-P32	36	6.6	36	18	26	20	30	3	50	3010	-
OSP-P40	54	9	30	12.5	24	24	38	-	68	-	4010
OSP-P50	70	9	40	12.5	24	30	48	-	86	-	5010
OSP-P63	78	11	48	15	30	40	57	-	104	-	6010
OSP-P80	96	14	60	17.5	35	50	72	-	130	-	8010

(* = Pair)

Linear Drive Accessories

∅ 10-80 mm

Mid-Section Support

B



For Linear-drive
 • Series OSP-P

Note on Types E1 and D1

(P16 – P80):

The mid-section support can also be mounted on the underside of the actuator, in which case its distance from the center of the actuator is different.

Stainless steel version on demand.



Series OSP-10, Type E1
 (Mounting from above / below using a cap screw)

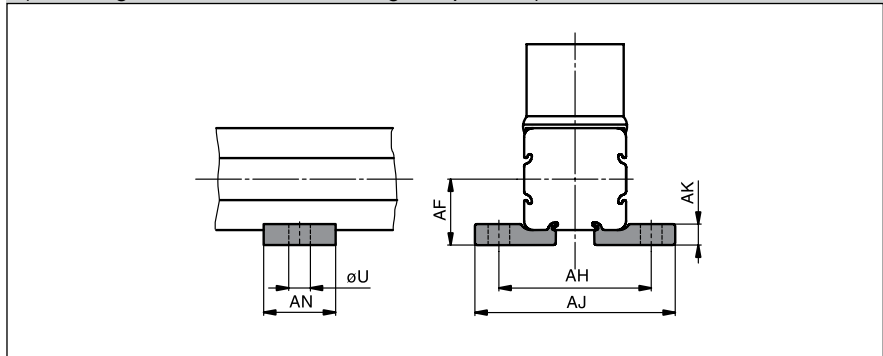

Series OSP-P16 to P80: Type E1
 (Mounting from above / below using a cap screw)

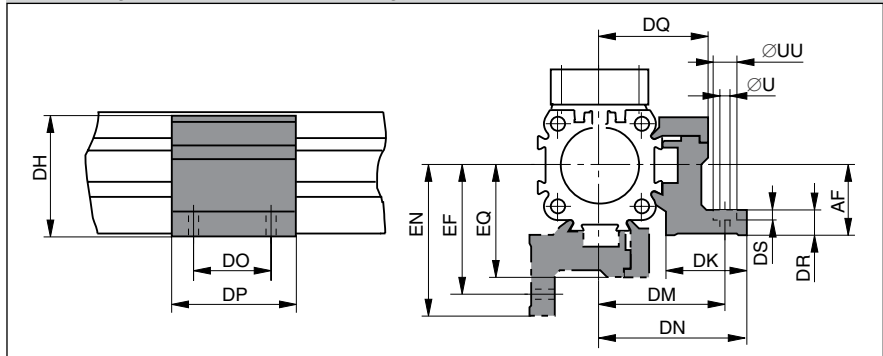

Series OSP-16 to 80, Type D1
 (Mountings from below with 2 screws)

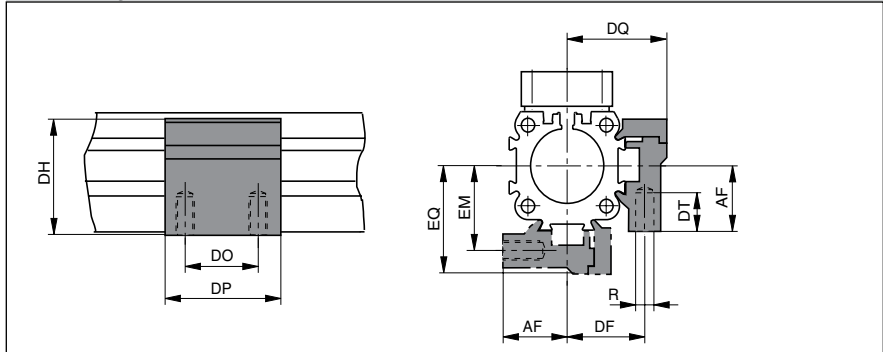

Dimension Table (mm) Series OSP-P10

Series	U	AF	AH	AJ	AK	AN	Order No.	
							Type E1	Type D1
OSP-P10	3.6	11	25.4	33.4	3.5	12	0250	-

Dimension Table (mm) – Series OSP-P16 to P80

Series	R	U	UU	AF	DF	DH	DK	DM	DN	DO	DP	DQ	DR	DS	DT	EF	EM	EN	EQ	Order No.	
																				Type E1	Type D1
OSP-P16	M3	3.4	6	15	20	29.2	24	32	36.4	18	30	27	6	3.4	6.5	32	20	36.4	27	20435	20434
OSP-P25	M5	5.5	10	22	27	38	26	40	47.5	36	50	34.5	8	5.7	10	41.5	28.5	49	36	20009	20008
OSP-P32	M5	5.5	10	30	33	46	27	46	54.5	36	50	40.5	10	5.7	10	48.5	35.5	57	43	20158	20157
OSP-P40	M6	7	-	38	35	61	34	53	60	45	60	45	10	-	11	56	38	63	48	20028	20027
OSP-P50	M6	7	-	48	40	71	34	59	67	45	60	52	10	-	11	64	45	72	57	20163	20162
OSP-P63	M8	9	-	57	47.5	91	44	73	83	45	65	63	12	-	16	79	53.5	89	69	20452	20451
OSP-P80	M10	11	-	72	60	111.5	63	97	112	55	80	81	15	-	25	103	66	118	87	20482	20480



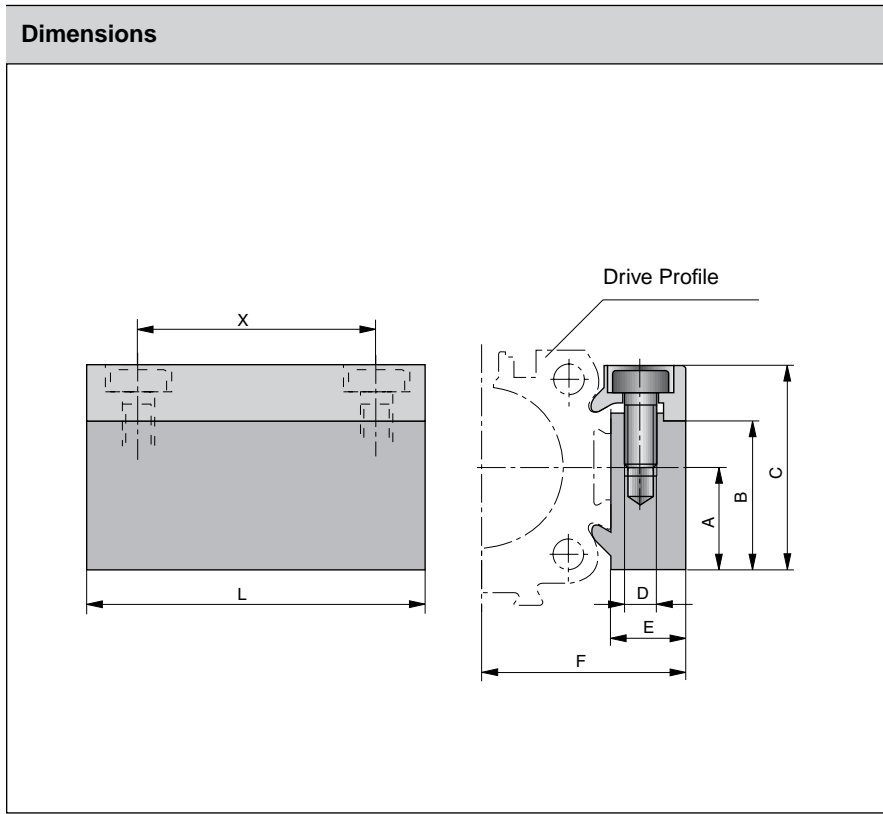

Linear Drive Accessories

∅ 16-50 mm Adaptor Profile



For Linear-drive
 • Series OSP-P

Adaptor Profile OSP

- A universal attachment for mounting of valves etc.
- Solid material



Dimension Table (mm)

Series	A	B	C	D	E	F	L	X	Order No.	
									Standard	Stainless
OSP-P16	14	20.5	28	M3	12	27	50	38	20432	20438
OSP-P25	16	23	32	M5	10.5	30.5	50	36	20006	20186
OSP-P32	16	23	32	M5	10.5	36.5	50	36	20006	20186
OSP-P40	20	33	43	M6	14	45	80	65	20025	20267
OSP-P50	20	33	43	M6	14	52	80	65	20025	20267



Linear Drive Accessories

∅ 16-50 mm T-Slot Profile

Dimensions

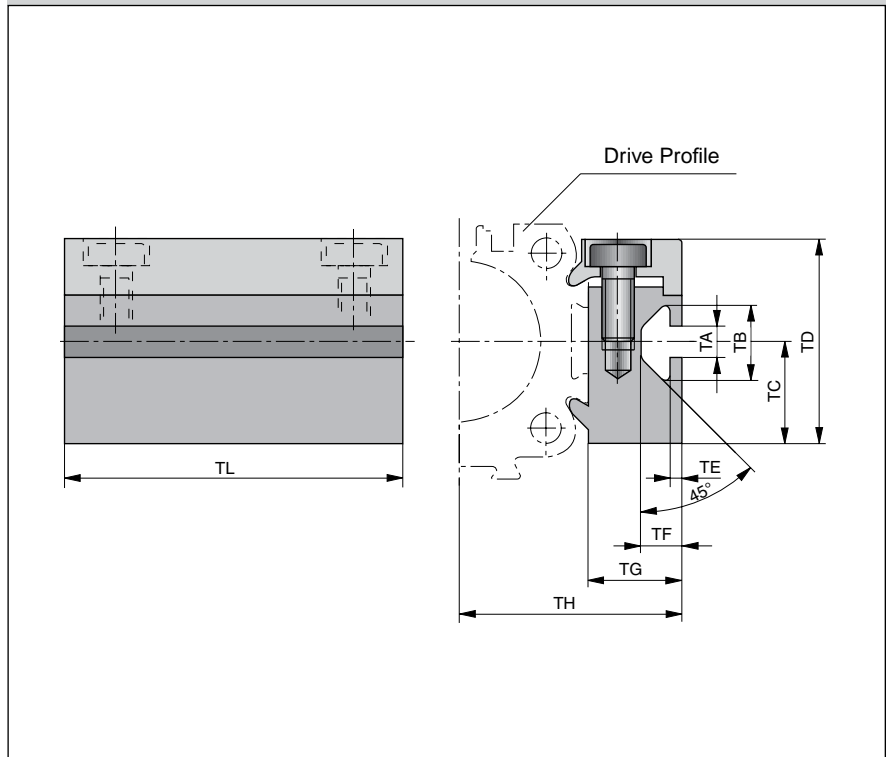

B



For Linear-drive
• Series OSP-P

T-Slot Profile OSP

- A universal attachment for mounting with standard T-Nuts

Dimension Table (mm)

Series	TA	TB	TC	TD	TE	TF	TG	TH	TL	Order No.	
										Standard	Stainless
OSP-P16	5	11.5	14	28	1.8	6.4	12	27	50	20433	20439
OSP-P25	5	11.5	16	32	1.8	6.4	14.5	34.5	50	20007	20187
OSP-P32	5	11.5	16	32	1.8	6.4	14.5	40.5	50	20007	20187
OSP-P40	8.2	20	20	43	4.5	12.3	20	51	80	20026	20268
OSP-P50	8.2	20	20	43	4.5	12.3	20	58	80	20026	20268



Dimensions

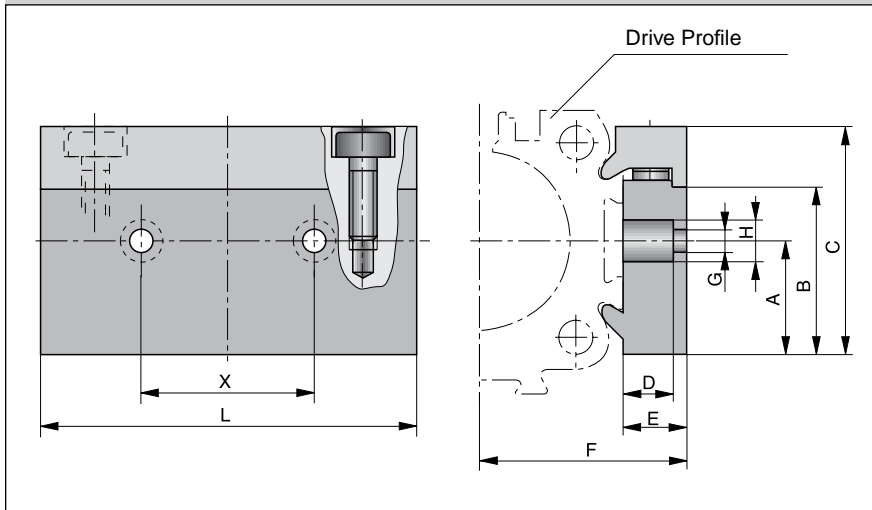

Linear Drive Accessories

∅ 16-50 mm
Connection Profile



For combining

- Series OSP-P with system profiles
- Series OSP-P with Series OSP-P



Dimension Table (mm)

Cylinder Series	for mounting on the carrier of	A	B	C	D	E	F	G	H	L	X	Order No.
OSP-P16	OSP25	14	20.5	28	8.5	12	27	5.5	10	50	25	20849
OSP-P25	OSP32-50	16	23	32	8.5	10.5	30.5	6.6	11	60	27	20850
OSP-P32	OSP32-50	16	23	32	8.5	10.5	36.5	6.6	11	60	27	20850
OSP-P40	OSP32-50	20	33	43	8	14	45	6.6	11	60	27	20851
OSP-P50	OSP32-50	20	33	43	8	14	52	6.6	11	60	27	20851

Possible Combinations

Combination of Series OSP-P with system profiles



Combination of Series OSP-P with Series OSP-P



Linear Drive Accessories

Ø 25-50 mm Joint Clamp Connection

B



For connection of cylinders of the Series OSP-P

The joint clamp connection combines two OSP-P cylinders of the same size into a compact unit with high performance.

Features

- Increased load and torque capacity
- Higher driving forces

Included in delivery:

- 2 clamping profiles with screws
- 1 mounting plate with fixings

Dimensions

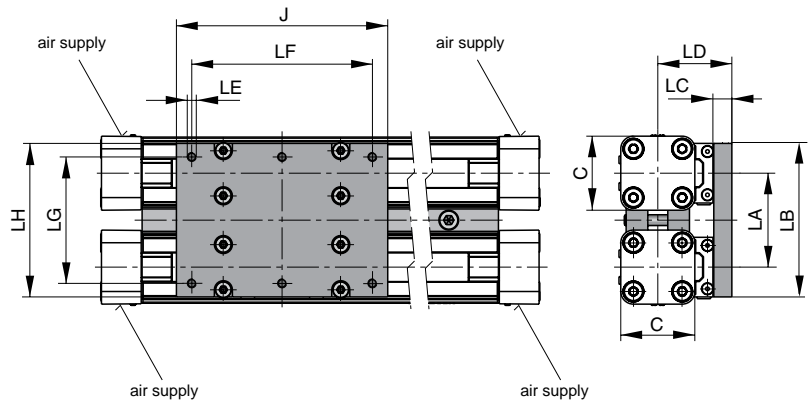

Dimension Table (mm)

Cylinder Series	C	J	LA	LB	LC	LD	LE	LF	LG	LH
OSP-P25	41	117	52	86	10	41	M5	100	70	85
OSP-P32	52	152	64	101	12	50	M6	130	80	100
OSP-P40	69	152	74	111	12	56	M6	130	90	110
OSP-P50	87	200	88	125	12	61	M6	180	100	124

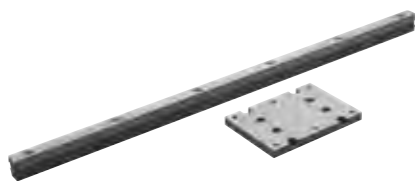
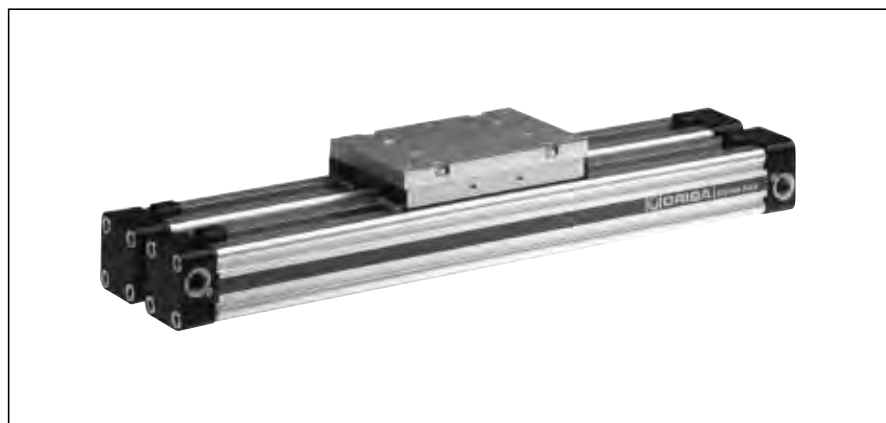

B

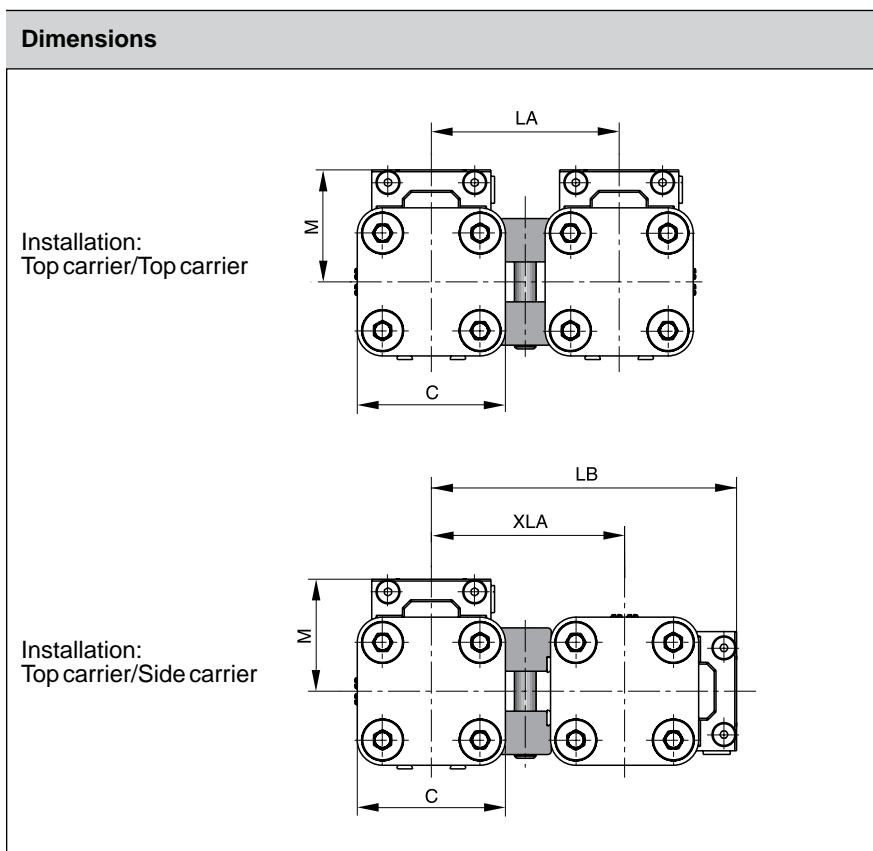

Linear Drive Accessories

ø 25-50 mm Multiplex Connection



For connection of cylinders of the Series OSP-P

The multiplex connection combines two or more OSP-P cylinders of the same size into one unit.

Features

- The orientation of the carriers can be freely selected

Included in delivery:

2 clamping profiles with clamping screws

Dimension Table (mm)

Cylinder Series	C	M	LA	LE	XLA	Order No.	
						Standard	Stainless
OSP-P25	41	31	52	84.5	53.5	20035	20193
OSP-P32	52	38	64	104.5	66.5	20167	20265
OSP-P40	69	44	74	121.5	77.5	20036	20275
OSP-P50	87	49	88	142.5	93.5	20168	20283

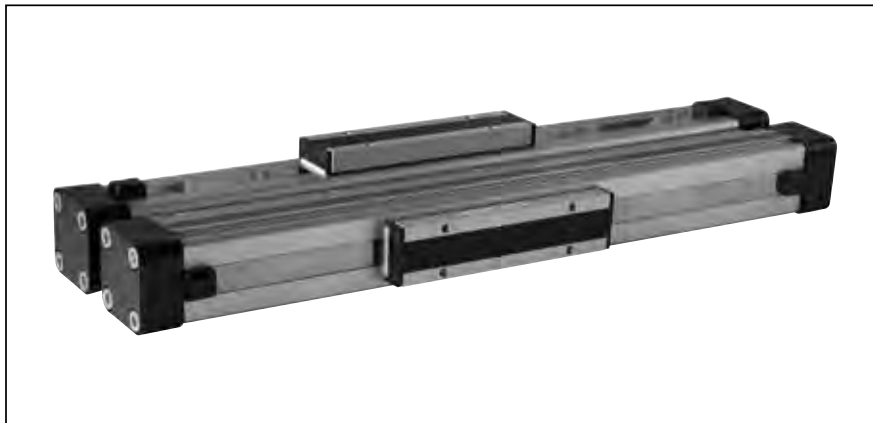

Ordering Instructions / Part Numbering System for OSP-P Rodless Basic Pneumatic Series

B

6	7	8	9	10	11	12-16	17	18	19	20	21	22	23	24	25								
OSPP	25	0	0	1	0	0	01100	0	0	1	0	0	0	0	0								
	Bore			Seals		Stroke		Piston Mountings		Dovetail Cover				Version									
	10 16 25 32 40 50 63 80			0 Standard 1 Viton S Special		x x x x x		0 None Floating 1 Mount (NR25) Joint 8 Clamp Plate (NR24) S Special		0 Standard X Without Cover Rail S Special													
		Piston Style			Lubrication						add. Carriage												
		0 Standard 1 Tandem S Special			0 Standard 1 Slow Speed 4 Food 5 Clean Room S Special						0 Without S Special												
						Corrosion Resist. Hardware			Guides / Brakes / Inversion Mounts			End Cap Mounts											
						0 Standard 1 Stainless S Special			0 None A AB Activebrake M Inversion (NR30) N Joint Clamp (25,32,40,50) S Special		0 Without 1 A1 (10,16,25,32) 2 A2 (16,25,32) 3 A3 (25,32) 4 B1 (25,32) 6 B3 (16) 7 B4 (25,32) 8 B5 (32) 9 C1 (40,50,63,80) A C2 (40,50) B C3 (40,50,63,80) C C4 (40,50)												
		Air Connections / Porting																					
		0 Standard (position #2) 1 End Face (position #5) 2 Single End Porting 3 Left Stand (pos #2), Right End Face (pos #5) 4 Right Stand (pos #2), Left End Face (pos #5) 6 Single End Porting End Face A 3/2 Way Valve VOE 24V = (25,32,40,50) B 3/2 Way Valve VOE 220V~/110V= (25,32,40,50) C 3/2 Way Valve VOE 48V=(25,32,40,50) E 3/2 Way Valve VOE 110V~ (25,32,40,50) S Special																					
								Cushioning / Stops															
								0 Standard S Special															
									End Cap Position														
									0 l+r 0° = In Front (pos #2) 1 l+r 90° = Underneath (pos #3) 2 l+r 180° = At the Back (pos #4) 3 l+r 270° = Same Face as Outerband (pos #2,1) 4 l 90° = Underneath; r 0° = In Front (pos #3,2) 5 l 180° = At the Back; r 0° = In Front (pos #4,2) 6 l 270° = Same Face as Outerband; r 0° = In Front (pos #1,2) 7 l 0° = In Front; r 90° = Underneath (pos #2,3) 8 l 180° = At the Back; r 90° = Underneath (pos #4,3) 9 l 270° = Same Face as Outerband; r 90° = Underneath (pos #1,3) A l 0° = In Front; r 180° = At the Back (pos #2,4) B l 90° = Underneath; r 180° = At the Back (pos #3,4) C l 270° = Same Face as Outerband; r 180° = At the Back (pos #1,4) D l 0° = In Front; r 270° = Same Face as Outerband (pos #2,1) E l 90° = Underneath; r 270° = Same Face as Outerband (pos #3,1) F l 180° = At the Back; r 270° = Same Face as Outerband (pos #4,1) S Special														
															Switches / Measuring System								
															0 none 1 NO Reed-KL3045 (All except 10mm) Qty. 2 2 NC Reed-KL3048 (All except 10mm) Qty. 2 3 PNP KL3054+4041 (All except 10mm) Qty. 2 4 NPN KL3060+4041 (All except 10mm) Qty. 2 5 NO Reed-KL3045 (10mm only) 6 PNP 3049+4041 (10mm only) Qty. 2 7 PNP 3753+4041 (10mm only) Qty. 2 X 21240 SFI 0,1mm Y 21241 SFI 1mm Z 4650 SFA S Special								
															Note: Comes in pairs								
															Note: 2 switches will be supplied. For different quantity, please order as a separate line item.								

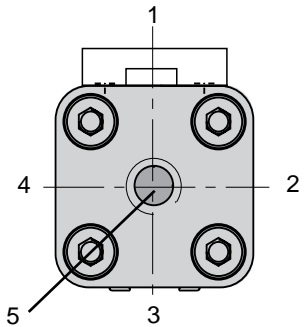

Note: Position #2 is the standard location.

Characteristics		Pressure quoted as gauge pressure	
Characteristics	Symbol	Unit	Description
General Features			
Type			Rodless Cylinder
Series			OSP-P
System			Double-acting, with cushioning, position sensing capability
Mounting			see drawings
Air connection			Threaded
Ambient and medium temperature range	T _{min} T _{max}	°C °C	-10 – other temperature ranges +80 on request
Weight (Mass)		kg	See table below
Installation			In any position
Medium			Filtered, unlubricated compressed air (other media on request)
Lubrication			Permanent grease lubrication (additional oil mist lubrication not required) Option: special slow speed grease
Material	Cylinder profile		Anodized aluminum
	Carrier (piston)		Anodized aluminum
	End caps		Aluminum, lacquered
	Sealing bands		Corrosion resistant steel
	Seals		NBR (Option: Viton®)
	Screws		Stainless steel
	Covers		Anodized aluminum
	Guide plate		Plastic
Max. operating pressure*	p _{max}	bar	8

* Pressure quoted as gauge pressure

Weight (Mass) kg

Cylinder series (basic cylinder)	Weight (Mass) kg	
	at 0 mm stroke	per 100 mm stroke
OSP-P16	0.22	0.1
OSP-P25	0.65	0.197
OSP-P32	1.44	0.354

Size Comparison

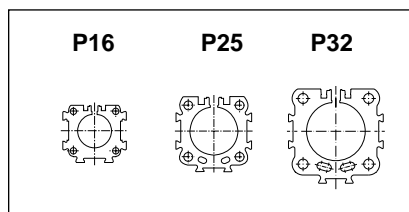

Clean Room Cylinder

∅ 16 – 32 mm

Rodless Cylinder

certified to
DIN EN ISO 14644-1



Standard Versions:

- Double-acting with adjustable end cushioning
- With magnetic piston for position sensing
- Stainless steel screws

Special Versions:

- Slow speed lubrication
- Viton® seals

Series OSP-P..

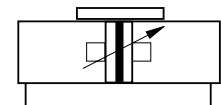

Features:

- Clean room classification
ISO Class 4 at v_m = 0.14 m/s
ISO Class 5 at v_m = 0.5 m/s
- Suitable for smooth slow speed operation up to v_{min} = 0.005 m/s
- Optional stroke length up to 1200 mm (longer strokes on request)
- Low maintenance
- Compact design with equal force and velocity in both directions
- Aluminum piston with bearing rings to support high direct and cantilever loads



B

Certification

Based on the PARKER-ORIGA rodless cylinder, proven in world wide markets, PARKER-ORIGA now offers the only rodless cylinder on the market with a certification from IPA Institute for the cleanroom specification according to DIN EN ISO 14644-1.



Function:

The clean room cylinders of the ORIGA SYSTEM PLUS (OSP-P) combines the efficiency of the PARKER-ORIGA slot seal system with vacuum protection against progressive wear and contamination from the sliding components. A partial vacuum drawn between inner and outer sealing bands prevents emission into the clean room. To achieve the necessary vacuum a suction flow of ca. 4 m³/h is required.

Function Diagram

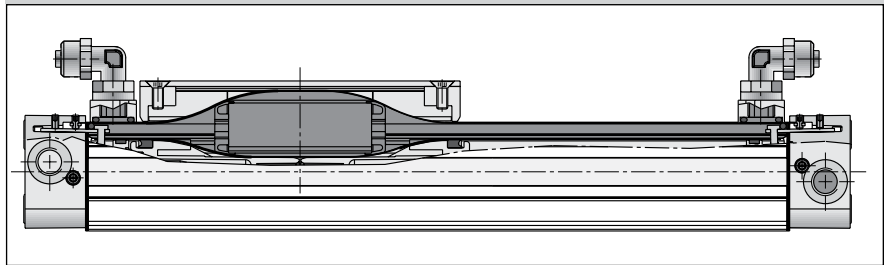

Loads, Forces and Moments

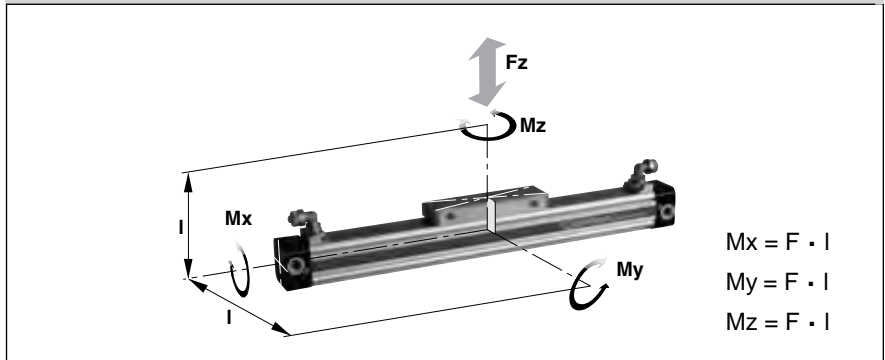

Cylinder Series (mm Ø)	Effective Force at 6 bar (N)	Max. Moment			Max. Load Fz (N)	Cushion length (mm)
		Mx (Nm)	My (Nm)	Mz (Nm)		
OSP-P16	78	0.45	4	0.5	120	11
OSP-P25	250	1.5	15	3.0	300	17
OSP-P32	420	3.0	30	5.0	450	20

Load and moment data are based on speeds $v \leq 0.2$ m/s. The adjacent table shows the maximum values for light, shock-free operation which must not be exceeded even in dynamic operation.

Dimensions

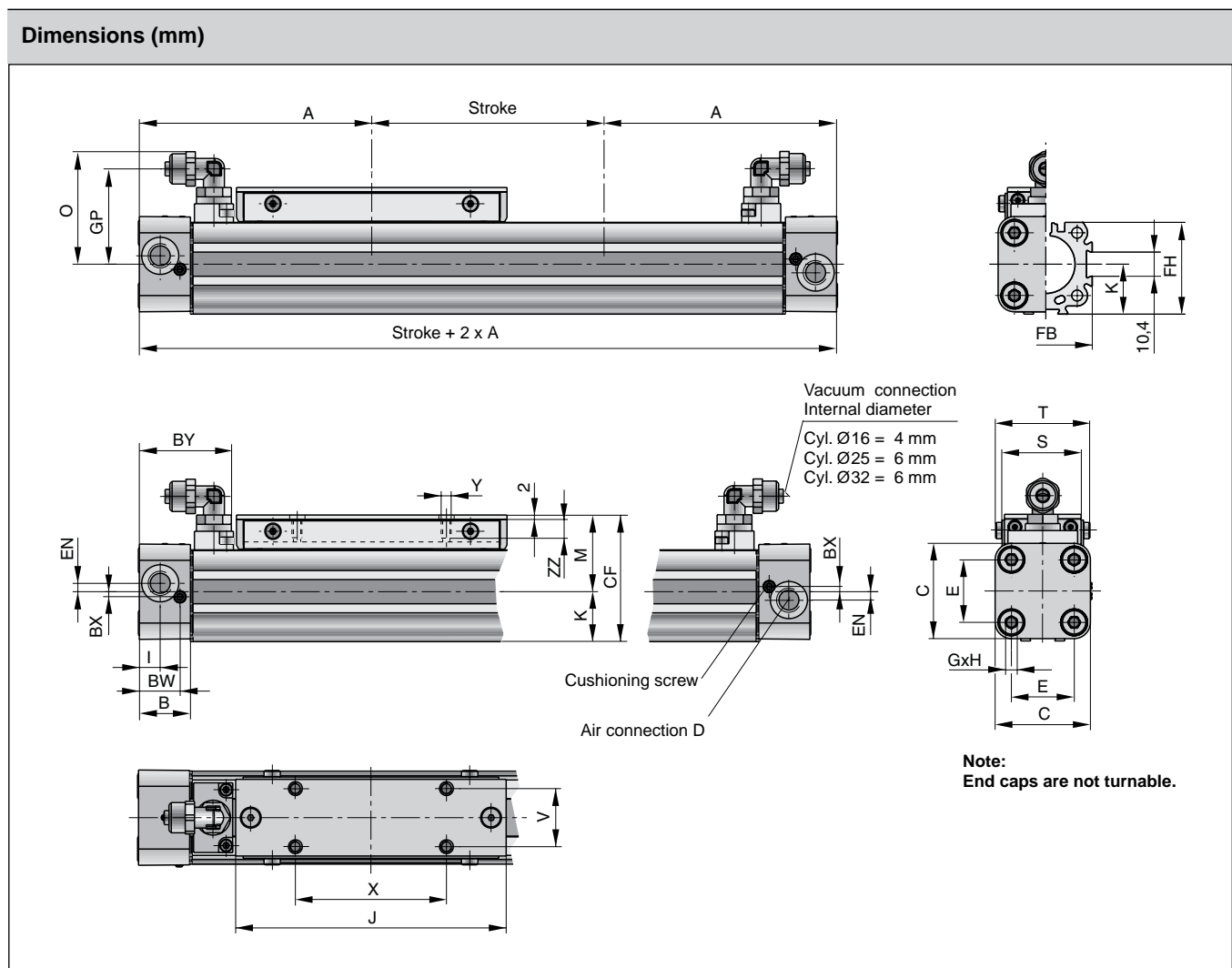

Dimension Table (mm)

Cylinder Series	A	B	C	D	E	G	H	I	J	K	M	O	S
OSP-P16	65	14	30	M5	18	M3	9	5.5	69	15	25	31	24
OSP-P25	100	22	41	G1/8	27	M5	15	9	117	21.5	33	48.5	35
OSP-P32	125	25.5	52	G1/4	36	M6	15	11.5	152	28.5	40	53.6	38

Cylinder Series	T	V	X	Y	BW	BX	BY	CF	EN	FB	FH	GP	ZZ
OSP-P16	29.6	16.5	36	M4	10.8	1.8	28.5	40	3	30	27.2	25.7	7
OSP-P25	40.6	25	65	M5	17.5	2.2	40.5	54.5	3.6	40	39.5	41	8
OSP-P32	45	27	90	M6	20.5	2.5	47.1	68.5	5.5	52	51.7	46.2	10

Ordering Instructions / Part Numbering System for OSP-P Clean Room Series

B

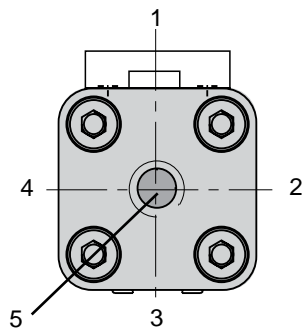
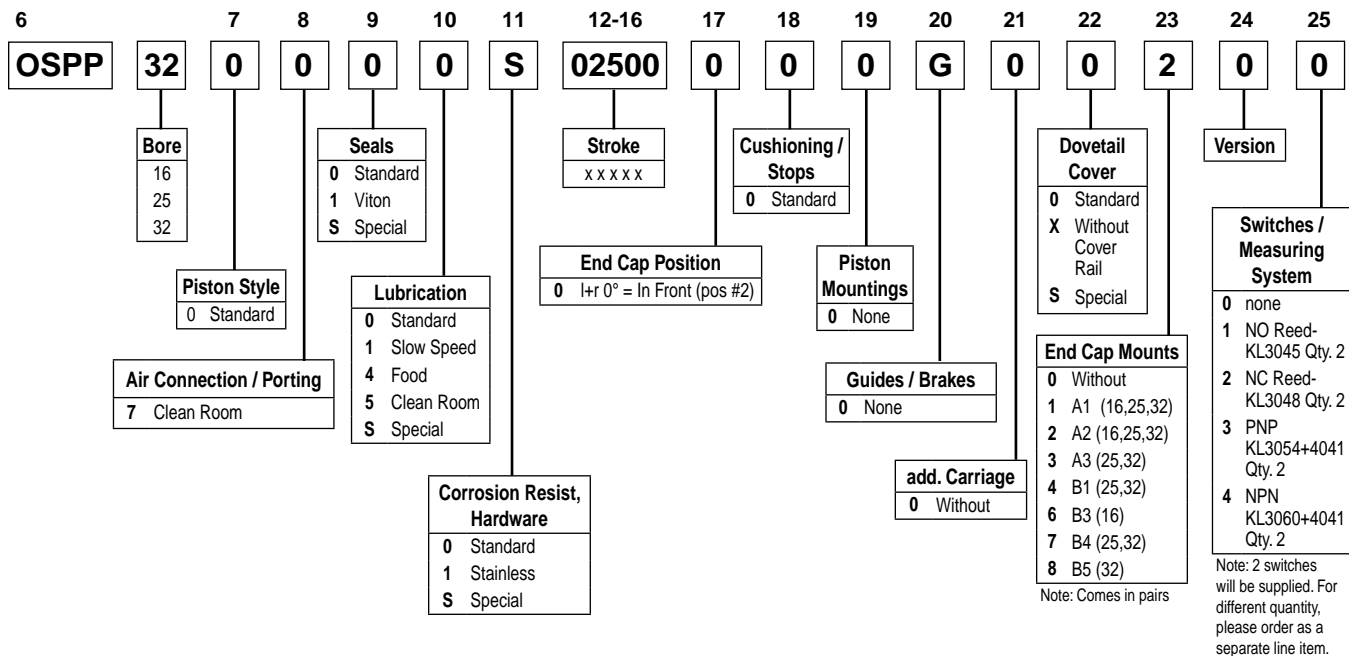

Note: Position #2 is the standard location.

Characteristics			
Characteristics	Symbol	Unit	Description
General Features			
Type			Rodless cylinder for synchronized bi-parting movements
Series			OSP-P
System			Double acting with end cushioning. For contactless position sensing
Guide			Slideline SL40
Synchronization			Toothed belt
Mounting			See drawings
Ambient temperature range	T_{min} T_{max}	°C °C	-10 +60
Weight (Mass)		kg	see table page B36
Medium			Filtered, unlubricated compressed air (other media on request)
Lubrication			Special slow speed grease – additional oil mist lubrication not required
Material			
Toothed Belt			Steel-corded polyurethane
Belt wheel			Aluminum
Operating pressure range	p_{max}	bar	6
Cushioning middle position			Elastic buffer
Max. Speed	v_{max}	m/s	0.2
Max. stroke of each stroke		mm	500
Max. mass per guide carrier		kg	25
Max. moments on guide carrier			
lateral moment	$M_{X_{max}}$	Nm	25
axial moment	$M_{Y_{max}}$	Nm	46
rotating moment	$M_{Z_{max}}$	Nm	46
For more technical information see pages B41			

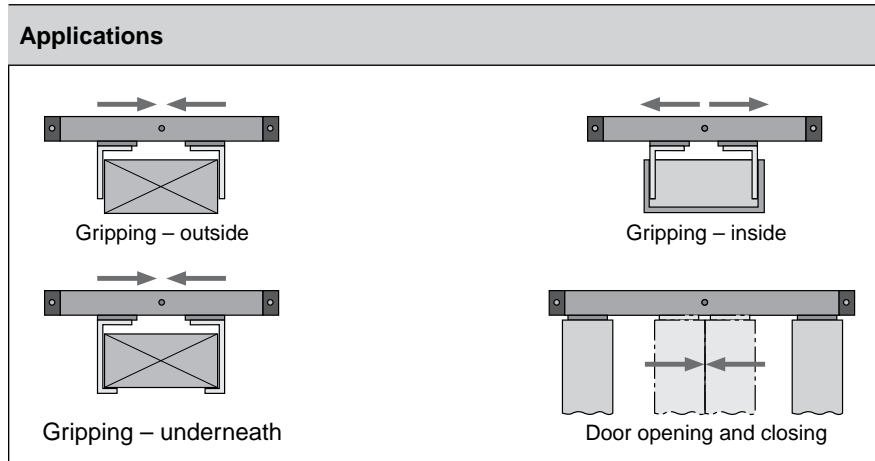

Rodless Cylinder Ø 40 mm

for synchronized
 bi-parting movements

Type OSP-P40-SL-BP

B



Features:

- Accurate bi-parting movement through toothed belt synchronization
- Optimum slow speed performance
- Increased action force
- Anodized aluminum guide rail with prism-form slideway arrangement
- Adjustable polymer slide units
- Combined sealing system with polymer and felt elements to remove dirt and lubricate the slideway
- Integrated grease nipples for guide lubrication

Applications:

- Opening and closing operations
- Gripping of workpieces – outside
- Gripping of hollow workpieces – inside
- Gripping underneath larger objects
- Clamping force adjustable via pressure regulator



B

Weight (mass) kg		
Cylinder series (Basic cylinder)	Weight (Mass) kg	
	At 0 mm stroke	per 100 mm stroke
OSP-P40-SL-BP	10.334	2.134

Function:

The OSP-P40-SL-BP bidirectional linear drive is based on the OSP-P40 rodless pneumatic cylinder and adapted SLIDELINE SL40 polymer plain-bearing guides.

Two pistons in the cylinder bore are connected via yokes and carriers to the SLIDELINE guide carriers, which handle the forces and moments generated.

The bi-parting movements of the guide carriers are accurately synchronized by a recirculating toothed belt.

The two pistons are driven from the middle to the end positions via a common G1/4 air connection in the middle of the cylinder, and are driven from the end positions to the middle via an air connection in each end cap.

End position cushioning is provided by adjustable air cushioning in the end caps, and middle position cushioning by rubber buffers.

Dimensions (mm)

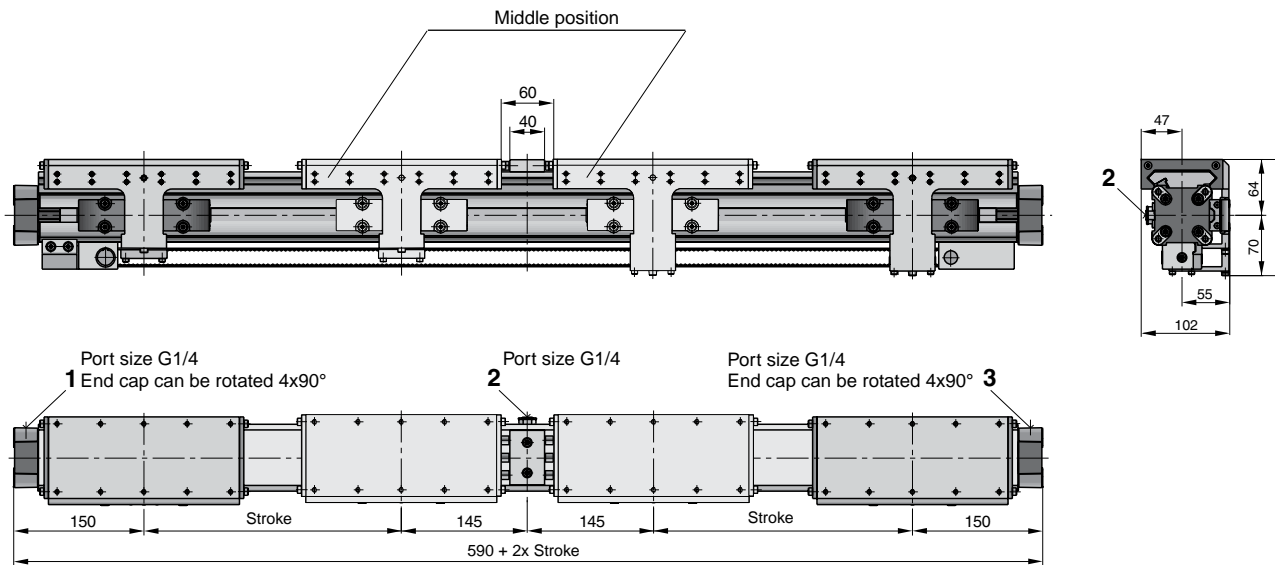

Air connections:

To drive the guide carriers to the middle position: pressurize ports 1 and 3.

To drive the guide carriers to the end positions: pressurize port 2.

For more dimensions see pages B11 and B42

Ordering Instructions / Part Numbering System for OSP-P Bi-Parting Rodless Cylinders Series

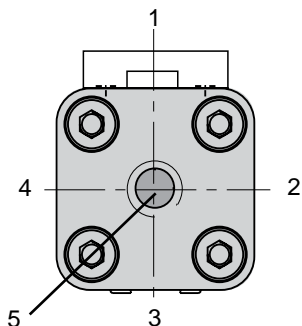
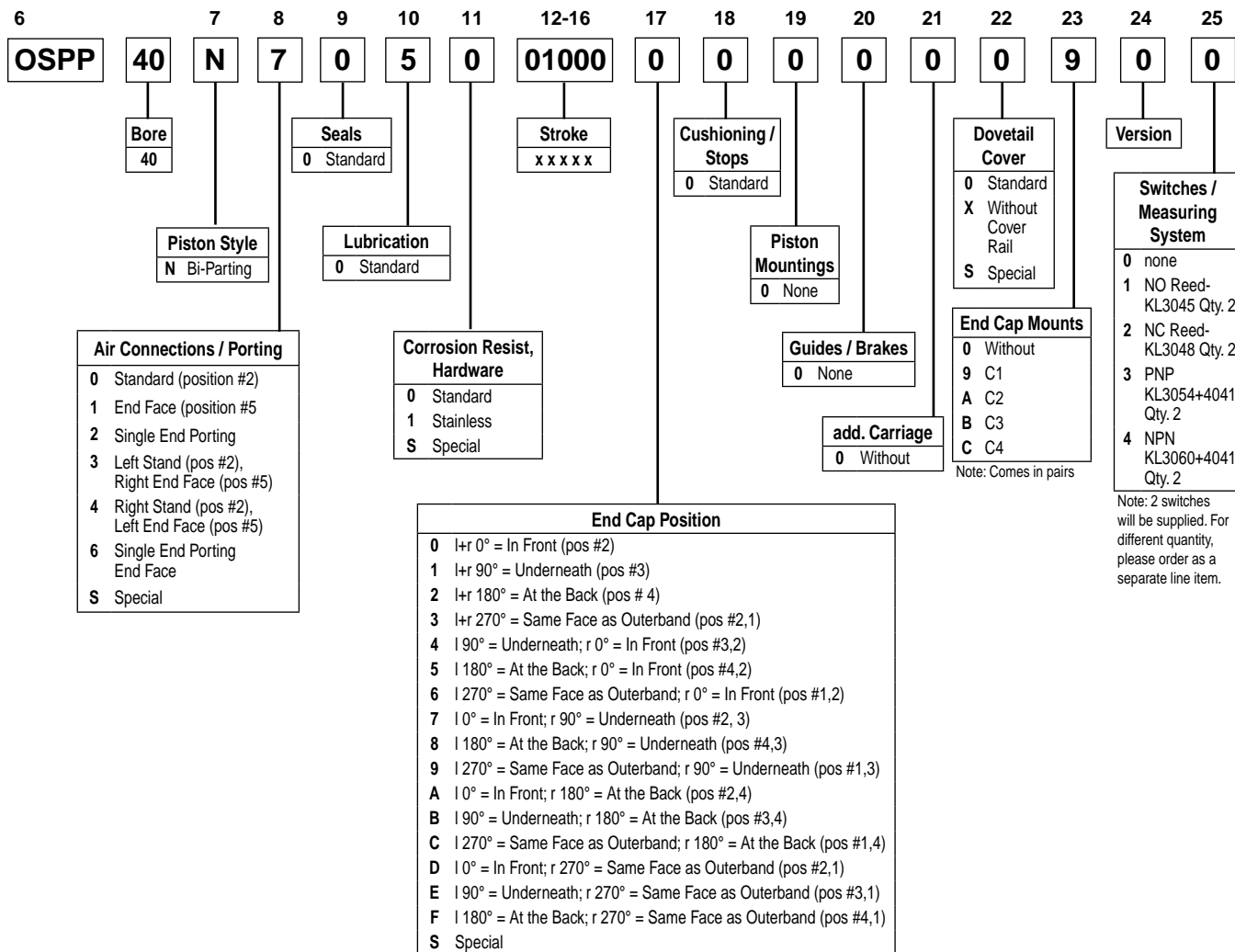

Note: Position #2 is the standard location.



B



Linear Guides for Series OSP-P

B



Overview.....	B40	Recirculating Ball Bearing Guide STARLINE	
Plain Bearing Guide SLIDELINE		Technical	B68-B70
Technical	B41	Dimensions	B69
Dimensions	B42	Variable Stops	B71-B73
Multi-Brakes	B43-B46	Accessories (Mountings & Supports)	B74-B77
Accessories (Mountings & Supports)	B47-B49	Ordering Information	B78
Ordering Information	B50	Recirculating Ball Bearing Guide KF	
Roller Guide POWERSLIDE		Technical	B79-B81
Technical	B51-B54	Dimensions	B80
Dimensions	B52	Variable Stops	B82-B84
Accessories (Mountings & Supports)	B55-B57	Accessories (Mountings & Supports)	B85-B90
Ordering Information	B58	Ordering Information	B91
Aluminum Roller Guide PROLINE		Heavy Duty Guide HD	
Technical	B59	Technical	B92
Dimensions	B60	Dimensions	B93-B94
Multi-Brakes	B61-B63	Variable Stops	B95
Accessories (Mountings & Supports)	B64-B66	Intermediate Stop.....	B96-B98
Ordering Information	B67	Ordering Information	B99



OSP

— ORIGA
— SYSTEM
— PLUS

B

Adaptive modular system

The Origa system plus – OSP – provides a comprehensive range of linear guides for the pneumatic and electric linear drives.

Advantages:

- Takes high loads and forces
- High precision
- Smooth operation
- Can be retrofitted
- Can be installed in any position

Rodless Pneumatic Cylinder
Series OSP - P

Piston diameters 10 – 80 mm

See page:
B7 (Standard)



Linear Guides

SLIDELINE

The cost-effective plain bearing guide for medium loads.
Active/ Passive Brake optional.
Piston diameters 16 – 80 mm



POWERSLIDE

The roller guide for heavy loads and hard application conditions
Piston diameters 16 – 50 mm



PROLINE

The compact aluminum roller guide for high loads and velocities.
Active/ Passive Brake optional.
Piston diameters 16 – 50 mm



STARLINE

Recirculating ball bearing guide for very high loads and precision
Piston diameters 16 – 50 mm



KF GUIDE

Recirculating ball bearing guide for highest loads and precision.
Correspond to FESTO dimensions (Type DGPL-KF)
Piston diameters 16 – 50 mm



HD HEAVY DUTY GUIDE

The ball bushing guide for the heavy loads and greatest accuracy.
Piston diameters 25 – 50 mm



Versions

for pneumatic linear drive:
Series OSP-P

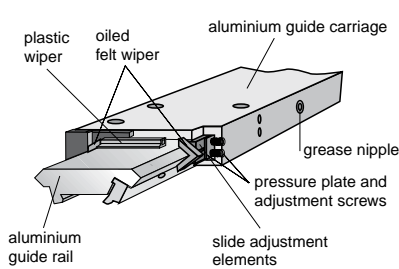

Option – Integrated Brake

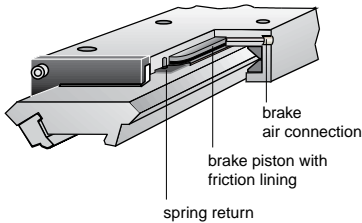

**Integrated Brake (optional)
for series OSP-P25 to OSP-P50:**

- Actuated by pressure
- Released by exhausting and spring return

For further technical data see also linear drives OSP-P (page B7)

Loads, Forces and Moments

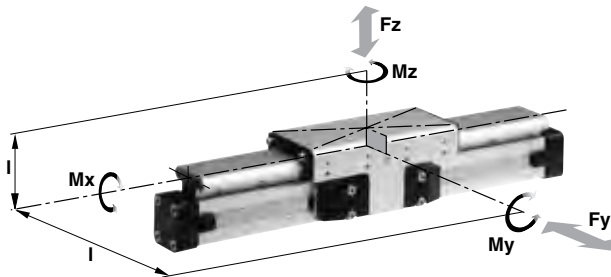

Technical Data

The table shows the maximum permissible values for smooth operation, which should not be exceeded even under dynamic conditions.

The load and moment figures apply to speeds $v < 0.2$ m/s.

*** Please note:**

In the cushioning diagram, add the mass of the guide carriage to the mass to be cushioned.

Plain Bearing Guide SLIDELINE



**Series SL 16 to 80
for Linear-drive
• Series OSP-P**

Features:

- Adjustable plastic slide elements – optional with integral brake
- Composite sealing system with plastic and felt wiper elements to remove dirt and lubricate the slideways.
- Corrosion resistant version available on request.
- Any length of stroke up to 5500 mm (longer strokes on request)

- 1) Only with integrated brake:
Braking force on dry oil-free surface
Values are decreased for lubricated slideways
- 2) Corrosion resistant fixtures available on request

Series	For linear drive	Max. moments (Nm)			Max. loads (N)	Maximum braking force at 6 bar (N) ¹⁾	Mass of linear drive with guide (kg)		Mass* of guide carriage (kg)
		Mx	My	Mz			Fy, Fz	with 0 mm stroke	
SL16	OSP-P16	6	11	11	325	–	0.57	0.22	0.23
SL25	OSP-P25	14	34	34	675	325	1.55	0.39	0.61
SL32	OSP-P32	29	60	60	925	545	2.98	0.65	0.95
SL40	OSP-P40	50	110	110	1500	835	4.05	0.78	1.22
SL50	OSP-P50	77	180	180	2000	1200	6.72	0.97	2.06
SL63	OSP-P63	120	260	260	2500	–	11.66	1.47	3.32
SL80	OSP-P80	120	260	260	2500	–	15.71	1.81	3.32



B

Dimensions

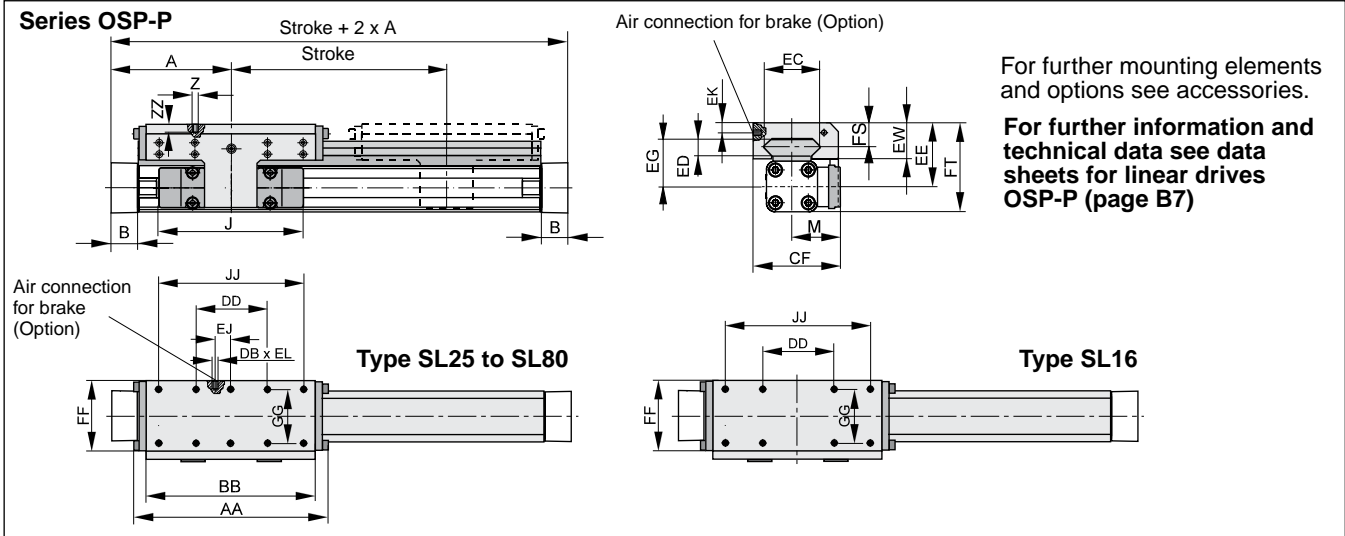

For further mounting elements and options see accessories.
 For further information and technical data see data sheets for linear drives OSP-P (page B7)

Dimension Table (mm)

Series	A	B	J	M	Z	AA	BB	DB	DD	CF	EC	ED	EE	EG	EJ	EK	EL	EW	FF	FT	FS	GG	JJ	ZZ
SL 16	65	14	69	31	M4	106	88	-	30	55	36	8	40	30	-	-	-	22	48	55	14	36	70	8
SL 25	100	22	117	40.5	M6	162	142	M5	60	72.5	47	12	53	39	22	6	6	30	64	73.5	20	50	120	12
SL 32	125	25.5	152	49	M6	205	185	M5	80	91	67	14	62	48	32	6	6	33	84	88	21	64	160	12
SL 40	150	28	152	55	M6	240	220	M5	100	102	77	14	64	50	58	6	6	34	94	98.5	21.5	78	200	12
SL 50	175	33	200	62	M6	284	264	M5	120	117	94	14	75	56	81	6	6	39	110	118.5	26	90	240	16
SL 63	215	38	256	79	M8	312	292	-	130	152	116	18	86	66	-	-	-	46	152	139	29	120	260	14
SL 80	260	47	348	96	M8	312	292	-	130	169	116	18	99	79	-	-	-	46	152	165	29	120	260	14

Mid-Section Support

(for versions see pages B47)

Mid-section supports are required from a certain stroke length to prevent excessive deflection and vibration of the linear drive. The diagrams show the maximum permissible unsupported length in relation to loading. A distinction must be drawn between loading 1 and loading 2. Deflection of 0.5 mm max. between supports is permissible.

Note:

For speeds $v > 0.5$ m/s the distance between supports should not exceed 1 m.

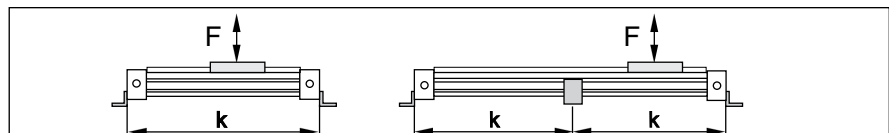
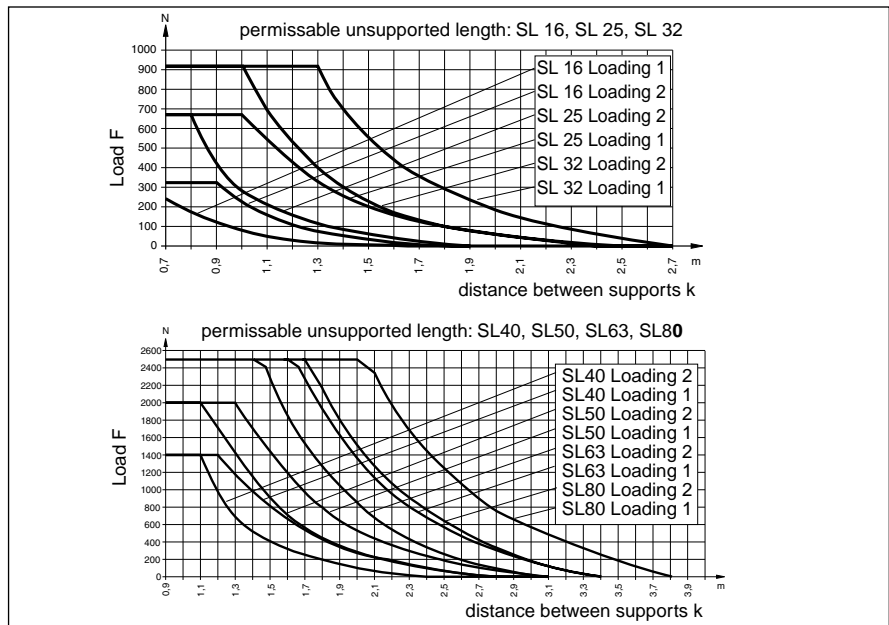
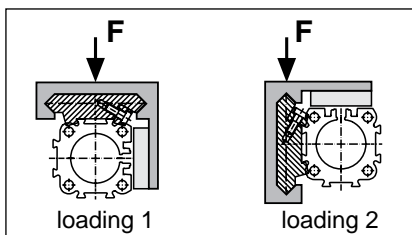

Features & Ordering Information

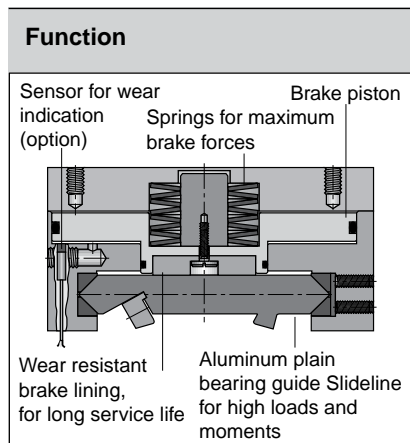
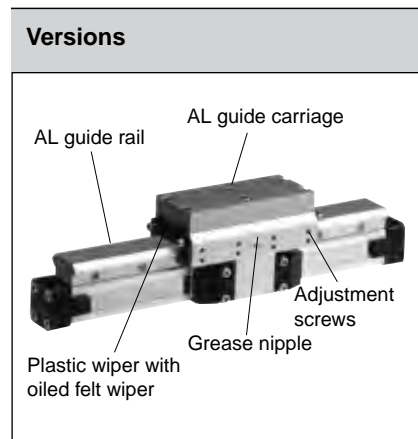

Multi-Brake Passive Brake with plain bearing guide Slideline SL



Function:

The Multi-Brake is a passive device. When the air pressure is removed the brake is actuated and movement of the cylinder is blocked. The brake is released by pressurization.

The high friction, wear resistant brake linings allow the Multi-Brake to be used as a dynamic brake to stop cylinder movement in the shortest possible time. The powerful springs also allow the Multi-Brake to be used effectively in positioning applications.

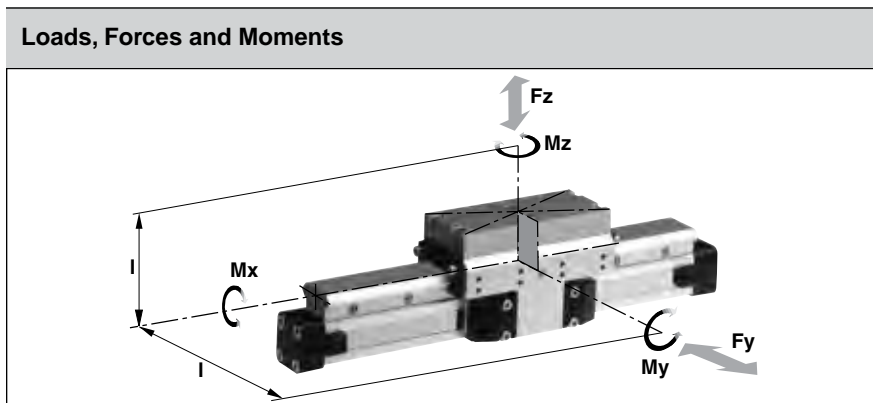

Technical Data:

The table shows the maximum values for light, shock-free operation, which must not be exceeded even in dynamic operation. Load and moment data are based on speeds $v < 0.2$ m/s.

Operating pressure 4.5 - 8 bar
A pressure of 4.5 bar is required to release the brake.
For further technical information, please refer to the data sheets for linear drives OSP-P (page B7)

Series MB-SL 25 to 80 for Linear-drive

- Series OSP-P

Features:

- Brake operated by spring actuation
- Brake release by pressurization
- Optional sensor to indicate brake lining wear
- Anodized aluminum rail, with prism shaped slide elements
- Adjustable plastic slide elements
- Composite sealing system with plastic and felt wiper elements to remove dirt and lubricate the slideway
- Replenishable guide lubrication by integrated grease nipples
- Blocking function in case of pressure loss
- Intermediate stops possible

¹⁾ Braking surface dry – oil on the braking surface will reduce the braking force

*** Please note:**

in the cushioning diagram, the mass of the guide carriage has to be added to the total moving mass.

Series	For linear drive	Max. moments (Nm)			Max. loads (N) Ly, Lz	Max. brake force (N) ¹⁾	Mass of linear drive with guide (kg)		Mass* guide carriage (kg)
		Mx	My	Mz			with 0 mm stroke	increase per 100 mm stroke	
MB-SL 25	OSP-P25	14	34	34	675	470	2.04	0.39	1.10
MB-SL 32	OSP-P32	29	60	60	925	790	3.82	0.65	1.79
MB-SL 40	OSP-P40	50	110	110	1500	1200	5.16	0.78	2.34
MB-SL 50	OSP-P50	77	180	180	2000	1870	8.29	0.97	3.63
MB-SL 63	OSP-P63	120	260	260	2500	2900	13.31	1.47	4.97
MB-SL 80	OSP-P80	120	260	260	2500	2900	17.36	1.81	4.97



Series OSP-P with Passive Brake MB-SL

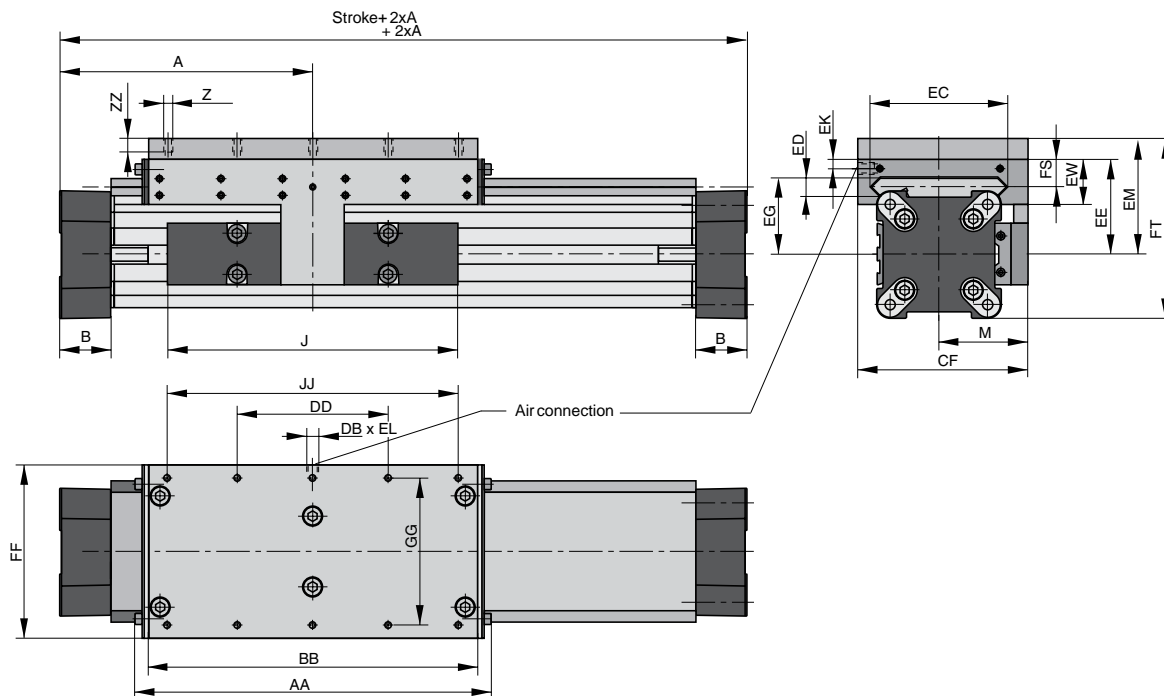

Dimension Table (mm)

Series	A	B	J	M	Z	AA	BB	DB	DD	CF	EC	ED	EE	EG	EK	EL	EM	EW	FF	FT	FS	GG	JJ	ZZ
MB-SL25	100	22	117	40,5	M6	162	142	M5	60	72.5	47	12	53	39	9	5	73	30	64	93.5	20	50	120	12
MB-SL32	125	25.5	152	49	M6	205	185	G1/8	80	91	67	14	62	48	7	10	82	33	84	108	21	64	160	12
MB-SL40	150	28	152	55	M6	240	220	G1/8	100	102	77	14	64	50	6.5	10	84	34	94	118.5	21.5	78	200	12
MB-SL50	175	33	200	62	M6	284	264	G1/8	120	117	94	14	75	56	10	12	95	39	110	138.5	26	90	240	12
MB-SL63	215	38	256	79	M8	312	292	G1/8	130	152	116	18	86	66	11	12	106	46	152	159	29	120	260	13
MB-SL80	260	47	348	96	M8	312	292	G1/8	130	169	116	18	99	79	11	12	119	46	152	185	29	120	260	13

Loading

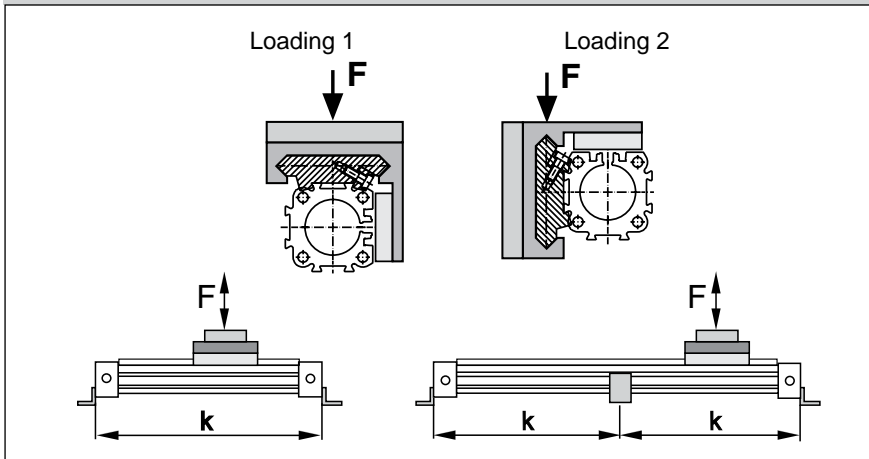

Mid Section Support

(for versions see page B47)

Mid-Section supports are required from a certain stroke length to prevent excessive deflection and vibration of the linear drive.

The diagrams show the maximum permissible unsupported length in relation to loading. A distinction must be drawn between loading 1 and loading 2. Deflection of 0.5 mm max. between supports is permissible.

Note:

For speeds $v > 0.5$ m/s the distance between supports should not exceed 1 m.

B

Permissible Unsupported Length MB-SL25, MB-SL32

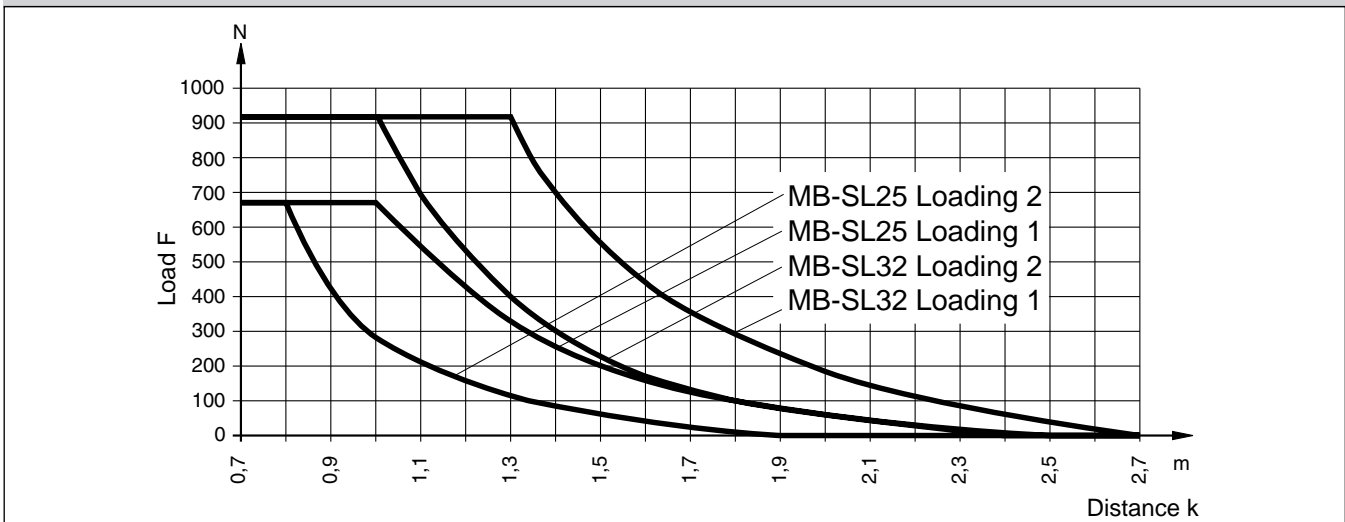

Permissible Unsupported Length MB-SL40, MB-SL50, MB-SL63 and MB-SL80

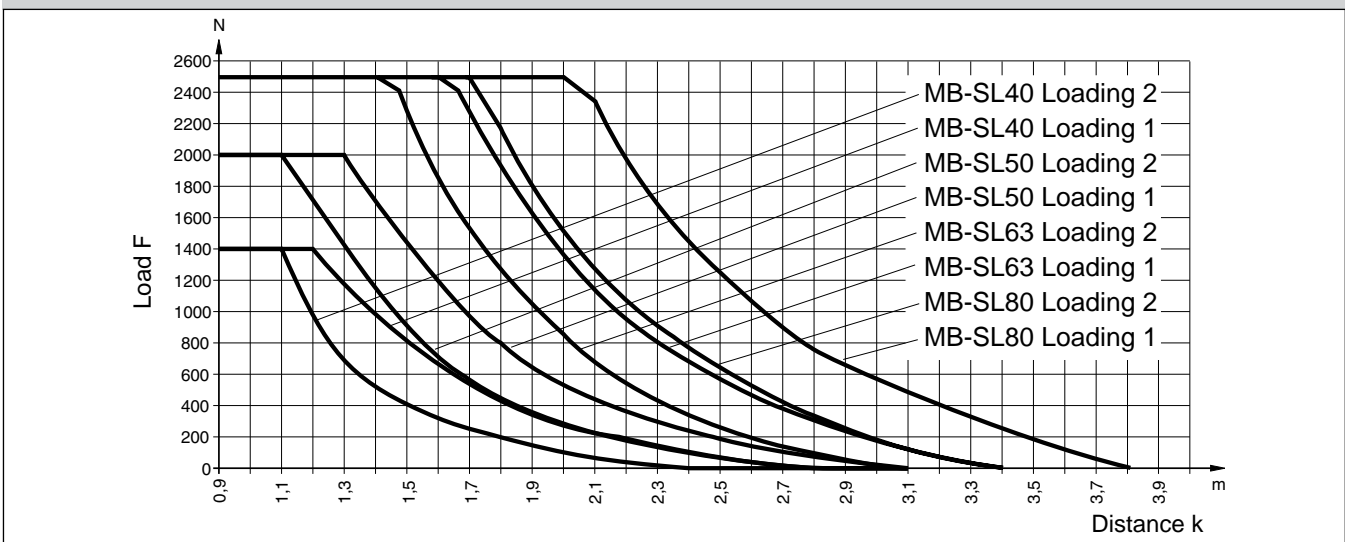

Application Example - Vertical Application

B

Control of a cylinder with 3/2 way valves. Basic position – **exhausted**

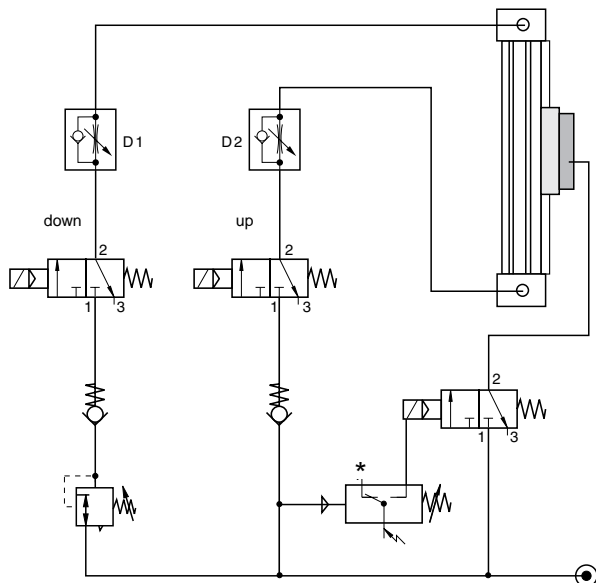

Control of a cylinder with 3/2 way valves. Basic position – **pressurized**

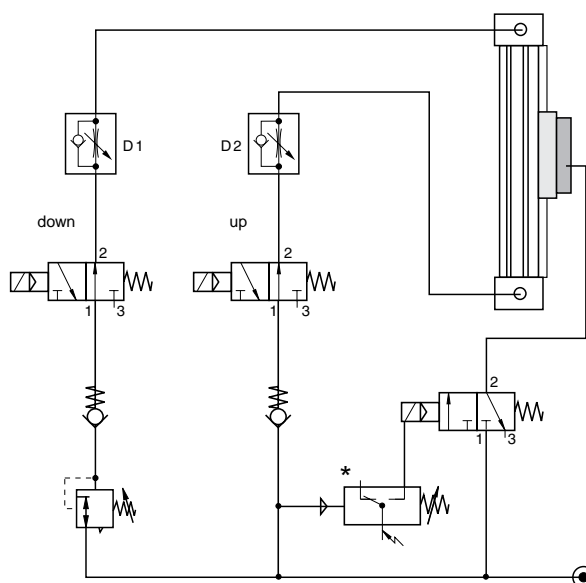

Control Examples

Under normal operating circumstances the pressure switch is closed and the air flows through the 3/2 way solenoid valves from port 1 to 2, thus lifting the brake from the rail (operating condition).

The brake is pressurized by means of a 3/2 way valve in combination with a pressure switch. When there is a pressure loss, the brake is actuated by the pressure switch.

When the air pressure is restored to both cylinder chambers, the brake is lifted and the linear drive can be moved again.

The speed regulating valves D1 and D2 control the speed of the linear drive, and have no influence on the brake. The two non-return valves give the system a higher stability.

The pressure regulating valve is used to compensate for the downward force in this vertical application.

Please note:



Before the brake is lifted, make sure that both air chambers of the linear drive are pressurized.

Small diameter tubing, fittings and valves with a nominal diameter, and tubing that is too long all change the reaction time of the brake!

***Tip:**

The pressure switch actuates the brake when the pressure drops below the set value.



For accessories, such as tubing and fittings, please refer to our separate catalogue.

Required Components

Way Valves
Port size
M5, G1/8
G1/4, G1/2
Pressure Regulating Valves
G1/8 - G3/8
Pneumatic Accessories
P/E-Switch
Non-Return Valves
G1/8 - G3/8
Screw-in Speed Regulating Valves
M5 - G1/4

Contact factory for literature on the above valves/accessories

OSP-Guide Mountings

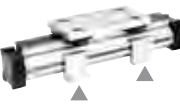
Overview		Type – OSP Guides																	
Mounting Type	Type	SLIDELINE PROLINE MULTIBRAKE						POWERSLIDE											
		16 ¹⁾	25	32	40	50	63 ¹⁾	80 ¹⁾	16/25	25/25	25/35	25/44	32/35	32/44	40/44	40/60	50/60	50/76	
End cap mounting 	Type A1	X							X										
	Type A2	O	O	O															
	Type A3										O	O		O					
End cap mounting, reinforced 	Type B1		X	X						X	X	X	X	X					
	Type B3								O										
	Type B4											O		O					
	Type B5																		
End cap mounting 	Type C1				X	X	X	X								X	X	X	X
	Type C2				O	O													
	Type C3						O	O								O		O	
	Type C4																O		O
Mid-Section support, small Mid-Section support, wide 	Type D1	X	X	X	X	X	X	X	X	X	X	X	X	X	X	X	X	X	X
	Type E1	X	X	X	X	X	X	X	X	X	X	X	X	X	X	X	X	X	X
	Type E2	O	O	O	O	O													
	Type E3						O	O	O	O	O		O		O		O		
	Type E4											O		O		O		O	
	Type E5																		

- X = carriage mounted in top (12 o'clock position)
- O = carriage mounted in lateral (3 or 9 o'clock position)
- = available components

1) = not available for all sizes

Linear Drive Accessories

Mountings for Linear Drives fitted with OSP-Guides



For Linear-drives
 • Series OSP-P



End Cap Mountings

End Cap Mountings

Four internal screw threads are located in the end faces of all OSP actuators for mounting the drive unit. End cap mountings may be secured across any two adjacent screws.

Material: Series OSP-16, 25, 32:
Galvanized steel
Series OSP-40,50, 63, 80:
Anodized aluminum

The mountings are supplied in pairs.

Series OSP-P16,25,32:Type A

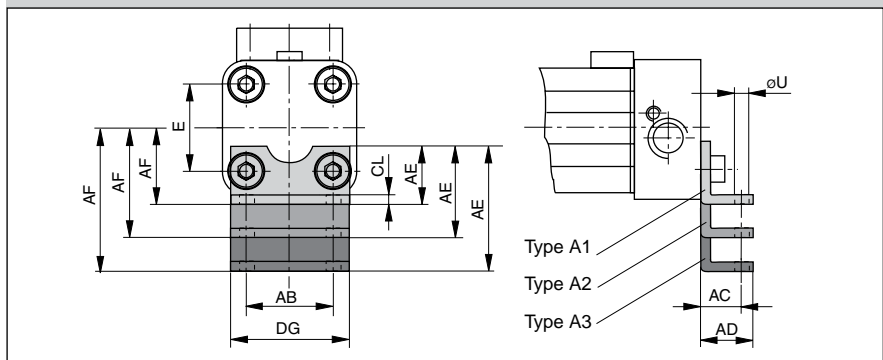

Series OSP-P16,25,32:Type B

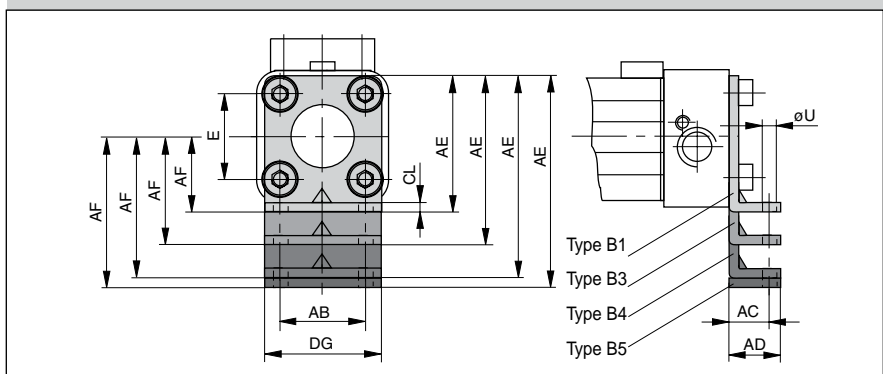

Series OSP-P40,50,63,80:Type C

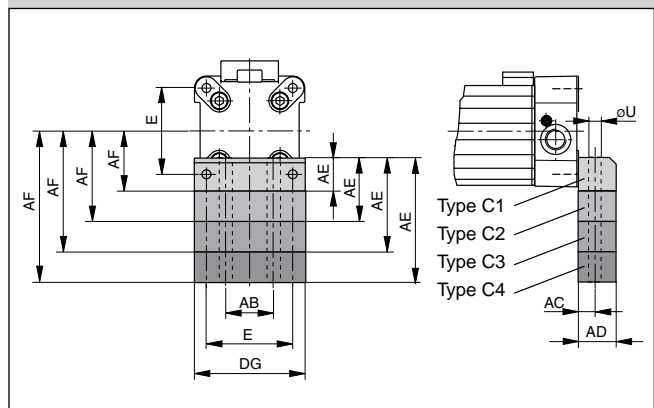

Dimension Table (mm)
– Dimensions AE and AF (Dependent on the mounting type)

Mount. type	Dimensions AE for size								AF for size							
	16	25	32	40	50	63	80	16	25	32	40	50	63	80		
A1	12.5	18	20	-	-	-	-	15	22	30	-	-	-	-		
A2	27.5	33	34	-	-	-	-	30	37	44	-	-	-	-		
A3	-	45	42	-	-	-	-	-	49	52	-	-	-	-		
B1	-	42	55	-	-	-	-	-	22	30	-	-	-	-		
B3	55	-	-	-	-	-	-	42	-	-	-	-	-	-		
B4	-	80	85	-	-	-	-	-	60	60	-	-	-	-		
B5	-	-	90	-	-	-	-	-	-	65	-	-	-	-		
C1	-	-	-	24	30	40	50	-	-	-	38	48	57	72		
C2	-	-	-	37	39	-	-	-	-	-	51	57	-	-		
C3	-	-	-	46	54	76	88	-	-	-	60	72	93	110		
C4	-	-	-	56	77	-	-	-	-	-	70	95	-	-		

Dimension Table (mm)

Series	E	øU	AB	AC	AD	CL	DG
OSP-P16	18	3.6	18	10	14	1.6	26
OSP-P25	27	5.8	27	16	22	2.5	39
OSP-P32	36	6.6	36	18	26	3	50
OSP-P40	54	9	30	12.5	24	-	68
OSP-P50	70	9	40	12.5	24	-	86
OSP-P63	78	11	48	15	30	-	104
OSP-P80	96	14	60	17.5	35	-	130

B



Series OSP-P16 to 80: Type E
(Mounting from above / below using a cap screw)

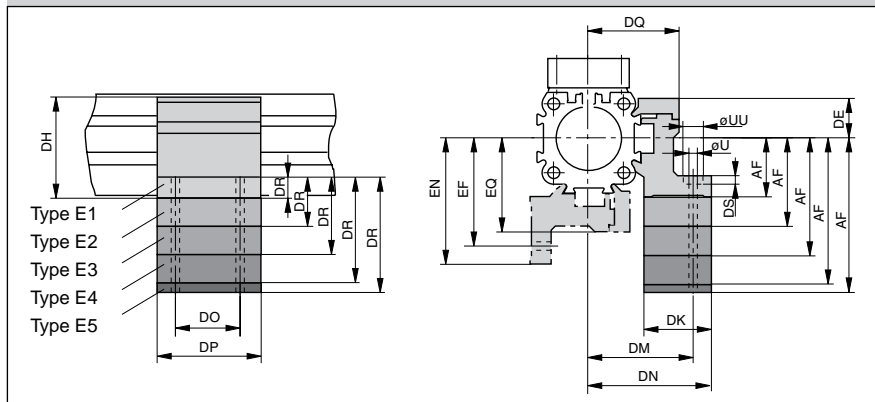

Mid-Section Support

Information regarding type E1 and D1:

Mounting of the Mid-Section supports is also possible on the lower side of the drive. In this case, please note the new center line dimensions.

Stainless steel version on request.



B

Series OSP-P16 to 80: Type D1
(Mounting from below with thread screw)

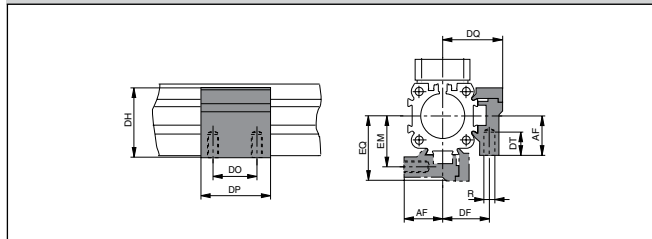

Dimension Table (mm)
– Dimensions AF and DR (Dependent on the mounting type)

Mount. type	Dimensions DR for size								Dimensions AF for size							
	16	25	32	40	50	63	80	16	25	32	40	50	63	80		
D1	-	-	-	-	-	-	-	15	22	30	38	48	57	72		
E1	6	8	10	10	10	12	15	15	22	30	38	48	57	72		
E2	21	23	24	23	19	-	-	30	37	44	51	57	-	-		
E3	33	35	32	32	34	48	53	42	49	52	60	72	93	110		
E4	-	46	40	42	57	-	-	60	60	70	95	-	-	-		
E5	-	-	45	-	-	-	-	-	-	65	-	-	-	-		

Dimension Table (mm)

Series	R	U	UU	DE	DF	DH	DK	DM	DN	DO	DP	DQ	DS	DT	EF	EM	EN	EQ
OSP-P16	M3	3.4	6	14.2	20	29.2	24	32	36.4	18	30	27	3.4	6.5	32	20	36.4	27
OSP-P25	M5	5.5	10	16	27	38	26	40	47.5	36	50	34.5	5.7	10	41.5	28.5	49	36
OSP-P32	M5	5.5	10	16	33	46	27	46	54.5	36	50	40.5	5.7	10	48.5	35.5	57	43
OSP-P40	M6	7	-	23	35	61	34	53	60	45	60	45	-	11	56	38	63	48
OSP-P50	M6	7	-	23	40	71	34	59	67	45	60	52	-	11	64	45	72	57
OSP-P63	M8	9	-	34	47.5	91	44	73	83	45	65	63	-	16	79	53.5	89	69
OSP-P80	M10	11	-	39.5	60	111.5	63	97	112	55	80	81	-	25	103	66	118	87

Ordering information for mountings Type A – Type B – Type C – Type D – Type E

Mounting type (versions)	Order No.						
	size						
	16	25	32	40	50	63	80
A1 *)	20408	2010	3010	-	-	-	-
A2 *)	20464	2040	3040	-	-	-	-
A3 *)	-	2060	3060	-	-	-	-
B1 *)	-	20311	20313	-	-	-	-
B3 *)	20465	-	-	-	-	-	-
B4 *)	-	20312	20314	-	-	-	-
B5 *)	-	-	20976	-	-	-	-
C1 *)	-	-	-	4010	5010	6010	8010
C2 *)	-	-	-	20338	20349	-	-
C3 *)	-	-	-	20339	20350	20821	20822
C4 *)	-	-	-	20340	20351	-	-
D1	20434	20008	20157	20027	20162	20451	20480
E1	20435	20009	20158	20028	20163	20452	20482
E2	20436	20352	20355	20358	20361	-	-
E3	20437	20353	20356	20359	20362	20453	20819
E4	-	20354	20357	20360	20363	-	-
E5	-	-	20977	-	-	-	-

(* Pair)

Ordering Instructions / Part Numbering System for OSP-P SLIDELINE Series

B

6	7	8	9	10	11	12-16	17	18	19	20	21	22	23	24	25
OSPP	25	0	2	0	0	01500	0	0	0	2	0	0	0	0	0
	Bore 16 25 32 40 50 63 80		Seals 0 Standard 1 Viton S Special			Stroke x x x x x		Piston Mountings 0 none				Dovetail Cover 0 Standard X Without Cover Rail S Special		Version	
		Piston Style 0 Standard 1 Tandem S Special		Lubrication 0 Standard 1 Slow Speed 4 Food 5 Clean Room S Special			Cushioning / Stops 0 Standard S Special								
					Corrosion Resist, Hardware 0 Standard 1 Stainless S Special		Guides / Brakes 2 SL Slideline 3 SL Slideline with Activebrake 4 SL Slideline with Multibrake (without sensors)					End Cap Mounts 0 without 1 A1 (16,25,32) 2 A2 (16,25,32) 3 A3 (25,32) 4 B1 (25,32) 6 B3 (16) 7 B4 (25,32) 8 B5 (32) 9 C1 (40,50,63,80) A C2 (40,50) B C3 (40,50,63,80) C C4 (40,50) <small>Note: Comes in pairs</small>		Switches / Measuring System 0 none 1 NO Reed-KL3045 Qty. 2 2 NC Reed-KL3048 Qty. 2 3 PNP KL3054+4041 Qty. 2 4 NPN KL3060+4041 Qty. 2 X 21240 SFI 0,1mm Y 21241 SFI 1mm Z 4650 SFA S Special <small>Note: 2 switches will be supplied. For different quantity, please order as a separate line item.</small>	
	Air Connections / Porting 0 Standard (position #2) 1 end face (position #5) 2 single end porting 3 left stand (pos #2), right end face (pos#5) 4 right stand (pos #2), left end face (pos #5) 6 single end porting end face A 3/2 Way valve VOE 24V = (25,32,40,50) B 3/2 Way valve VOE 220V~/110V= (25,32,40,50) C 3/2 Way valve VOE 48V=(25,32,40,50) E 3/2 Way valve VOE 110V~ (25,32,40,50) S Special <small>Note: Single End Porting on 16mm bore, then end caps cannot be rotated.</small>					End Cap Position 0 l+r 0° = in front (pos #2) 1 l+r 90° = underneath (pos #3) 2 l+r 180° = at the back (pos # 4) 3 l+r 270° = same face as outerband (pos #2,1) 4 l 90° = underneath; r 0° = in front (pos #3,2) 5 l 180° = at the back; r 0° = in front (pos #4,2) 6 l 270° = same face as outerband; r 0° = in front (pos #1,2) 7 l 0° = in front; r 90° = underneath (pos #2, 3) 8 l 180° = at the back; r 90° = underneath (pos #4,3) 9 l 270° = same face as outerband; r 90° = underneath (pos #1,3) A l 0° = in front; r 180° = at the back (pos #2,4) B l 90° = underneath; r 180° = at the back (pos #3,4) C l 270° = same face as outerband; r 180° = at the back (pos #1,4) D l 0° = in front; r 270° = same face as outerband (pos #2,1) E l 90° = underneath; r 270° = same face as outerband (pos #3,1) F l 180° = at the back; r 270° = same face as outerband (pos #4,1) S Special		add. Carriage 0 without 2 Guide Carriage Slideline SL 3 Guide Carriage SL-AB 4 Guide Carriage SL-MB M Guide Carriage SL-MB without Brake Function							

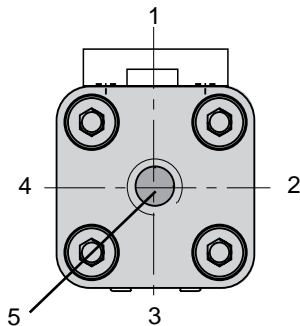

Note: Position #2 is the standard location.

Versions

for pneumatic linear drive:
Series OSP-P

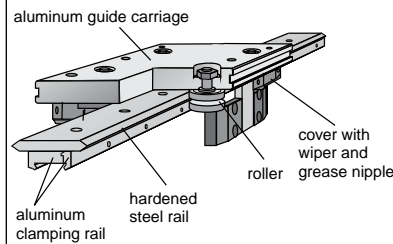

Roller Guide POWER- SLIDE



**Series PS 16 to 50
 for Linear-drive**
 • **Series OSP-P**

Loads, Forces and Moments

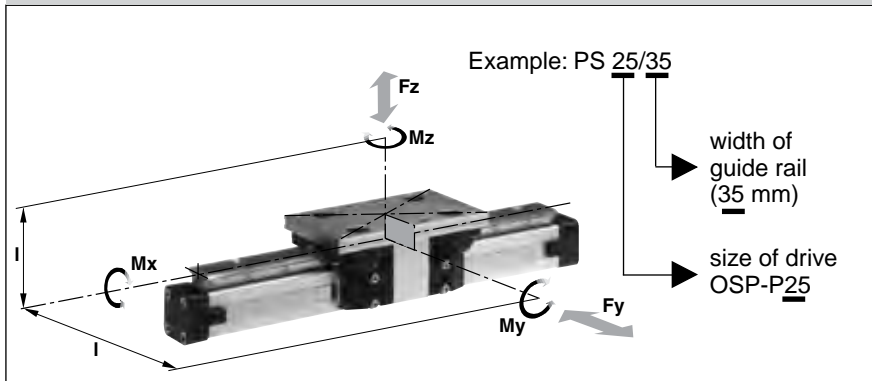

Features:

- Anodized aluminum guide carriage with vee rollers having 2 rows of ball bearings
- Hardened steel guide rail
- Several guide sizes can be used on the same drive
- Corrosion resistance version available on request
- Max. speed $v = 3 \text{ m/s}$,
- Tough roller cover with wiper and grease nipple
- Any length of stroke up to 3500 mm, (longer strokes on request)

Technical Data

The Table shows the maximum permissible values for smooth operation, which should not be exceeded even under dynamic conditions.

For further information and technical data see page B7 for linear drives OSP-P

*** Please note:**

In the cushioning diagram, add the mass of the guide carriage to the mass to be cushioned.

Series	For linear drive	Max. moments (Nm)			Max. load (N)	Mass of linear drive with guide (kg)		Mass* of guide carriage (kg)
		Mx	My	Mz		with 0 mm stroke	increase per 100 mm stroke	
PS 16/25	OSP-P16	14	45	45	1400	0.93	0.24	0.7
PS 25/25	OSP-P25	14	63	63	1400	1.5	0.4	0.7
PS 25/35	OSP-P25	20	70	70	1400	1.7	0.4	0.8
PS 25/44	OSP-P25	65	175	175	3000	2.6	0.5	1.5
PS 32/35	OSP-P32	20	70	70	1400	2.6	0.6	0.8
PS 32/44	OSP-P32	65	175	175	3000	3.4	0.7	1.5
PS 40/44	OSP-P40	65	175	175	3000	4.6	1.1	1.5
PS 40/60	OSP-P40	90	250	250	3000	6	1.3	2.2
PS 50/60	OSP-P50	90	250	250	3000	7.6	1.4	2.3
PS 50/76	OSP-P50	140	350	350	4000	11.5	1.8	4.9

¹⁾ corrosion resistance version available on request (max. loads and moments are 25% lower)



Dimensions

Dimensions

Series OSP-P

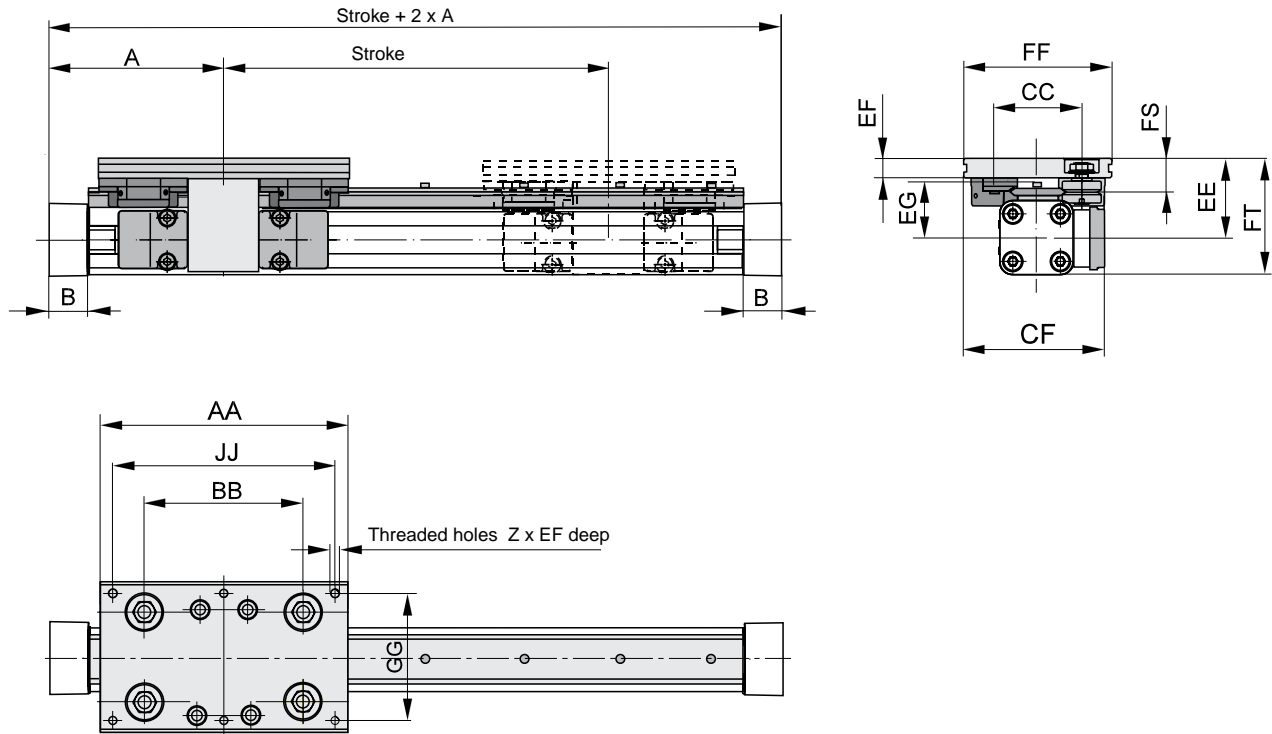

B

Dimension Table (mm)

Series	A	B	Z	AA	BB	CC	CF	EE	EF	EG	FF	FS	FT	GG	JJ
PS 16/25	65	14	4xM6	120	65	47	80	49	12	35	80	21	64	64	100
PS 25/25	100	22	6xM6	145	90	47	79.5	53	11	39	80	20	73.5	64	125
PS 25/35	100	22	6xM6	156	100	57	89.5	52.5	12.5	37.5	95	21.5	73	80	140
PS 25/44	100	22	6xM8	190	118	73	100	58	15	39	116	26	78.5	96	164
PS 32/35	125	25.5	6xM6	156	100	57	95.5	58.5	12.5	43.5	95	21.5	84.5	80	140
PS 32/44	125	25.5	6xM8	190	118	73	107	64	15	45	116	26	90	96	164
PS 40/44	150	28	6xM8	190	118	73	112.5	75	15	56	116	26	109.5	96	164
PS 40/60	150	28	6xM8	240	167	89	122.5	74	17	54	135	28.5	108.5	115	216
PS 50/60	175	33	6xM8	240	167	89	130.5	81	17	61	135	28.5	123.5	115	216
PS 50/76	175	33	6xM10	280	178	119	155.5	93	20	64	185	39	135.5	160	250

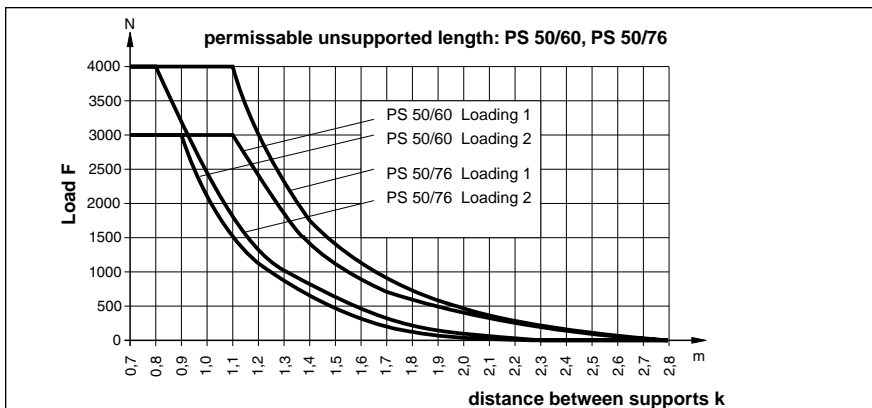
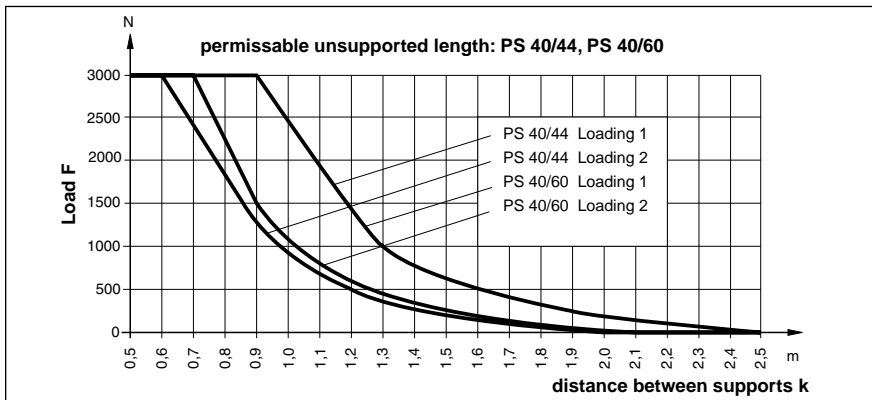
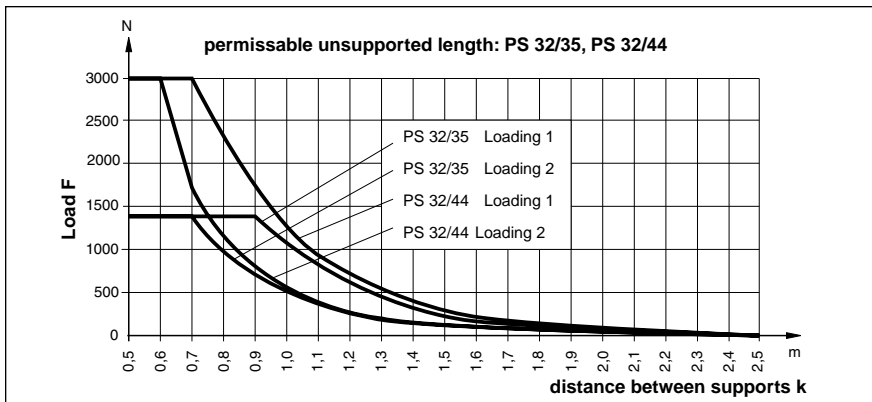
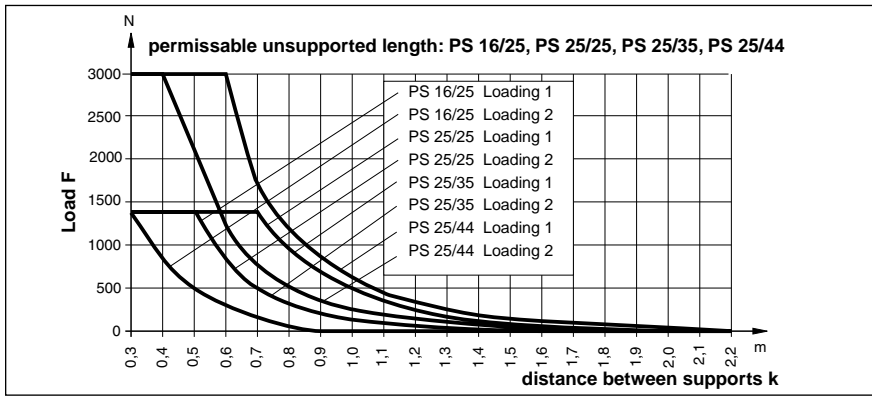

Mid-Section Support

(for versions, see accessories)

Mid-Section supports are required from a certain stroke length to prevent excessive deflection and vibration of the linear drive. The diagrams show the maximum permissible unsupported length in relation to loading.

A distinction must be drawn between loading 1 and loading 2.

Deflection of 0.5 mm max. between supports is permissible.

Note

For speeds $v > 0.5$ m/s the distance between supports should not exceed 1m.

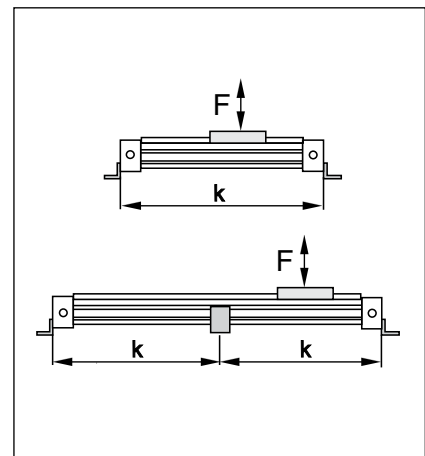
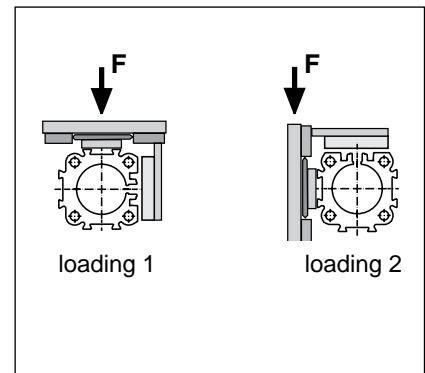

B

Service Life

Calculation of service life is achieved in two stages:

- Determination of load factor L_F from the loads to be carried
- Calculation of service life in km

1. Calculation of load factor L_F

$$L_F = \frac{M_x}{M_{x_{max}}} + \frac{M_y}{M_{y_{max}}} + \frac{M_z}{M_{z_{max}}} + \frac{F_y}{F_{y_{max}}} + \frac{F_z}{F_{z_{max}}}$$

with combined loads, L_F should not exceed the value 1.

2. Service life calculation

• For PS 16/25, PS 25/25, PS 25/35, and PS 32/35	Service life (km) =	$\frac{106}{(L_F + 0,02)^3}$
• For PS 25/44, PS 32/44, PS 40/44, PS 40/60 and PS 50/60:	Service life (km) =	$\frac{314}{(L_F + 0,015)^3}$
• For PS 50/76:	Service life (km) =	$\frac{680}{(L_F + 0,015)^3}$

Lubrication



For maximum system life, lubrication of the rollers must be maintained at all times.

Only high quality Lithium based greases should be used.

Lubrication intervals are dependent on environmental conditions

(temperature, running speed, grease quality etc.) therefore the installation should be regularly inspected.

B

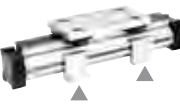
Overview		Type – OSP Guides																
Mounting Type	Type	SLIDELINE PROLINE MULTIBRAKE						POWERSLIDE										
		16 ¹⁾	25	32	40	50	63 ¹⁾	80 ¹⁾	16/25	25/25	25/35	25/44	32/35	32/44	40/44	40/60	50/60	50/76
End cap mounting 	Type A1	X							X									
	Type A2	O	O	O														
	Type A3									O	O		O					
End cap mounting, reinforced 	Type B1		X	X					X	X	X	X	X					
	Type B3								O									
	Type B4											O		O				
	Type B5																	
End cap mounting 	Type C1				X	X	X	X							X	X	X	X
	Type C2				O	O												
	Type C3						O	O							O		O	
	Type C4															O		O
Mid-Section support, small Mid-Section support, wide 	Type D1	X	X	X	X	X	X	X	X	X	X	X	X	X	X	X	X	X
	Type E1	X	X	X	X	X	X	X	X	X	X	X	X	X	X	X	X	X
	Type E2	O	O	O	O	O												
	Type E3						O	O	O	O	O		O		O		O	
	Type E4											O		O		O		O
	Type E5																	

- X = carriage mounted in top (12 o'clock position)
- O = carriage mounted in lateral (3 or 9 o'clock position)
- = available components

1) = not available for all sizes

Linear Drive Accessories

Mountings for Linear Drives fitted with OSP-Guides



For Linear-drives
• Series OSP-P

B



End Cap Mountings

Four internal screw threads are located in the end faces of all OSP actuators for mounting the drive unit. End cap mountings may be secured across any two adjacent screws.

Material: Series OSP-16, 25, 32:
Galvanized steel
Series OSP-40,50, 63, 80:
Anodized aluminum

The mountings are supplied in pairs.

Series OSP-P16,25,32:Type A

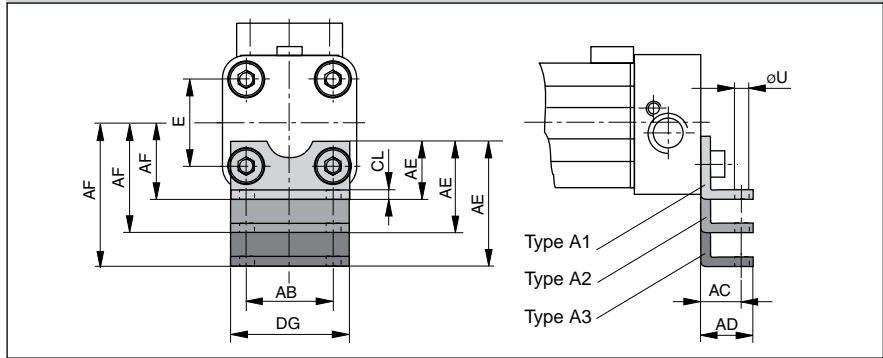

Series OSP-P16,25,32:Type B

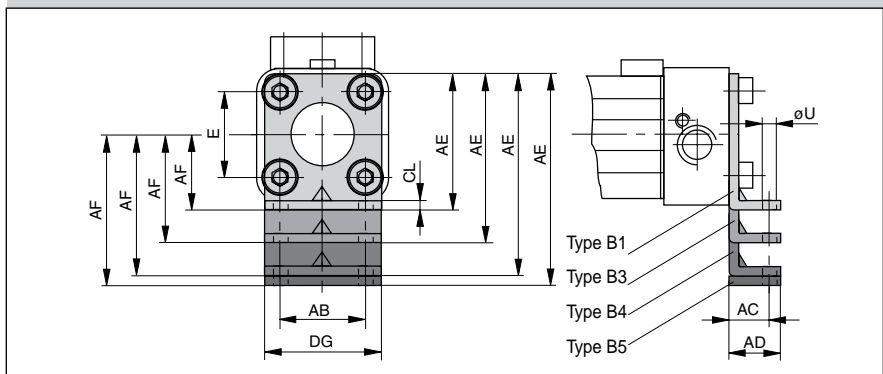

Series OSP-P40,50,63,80:Type C

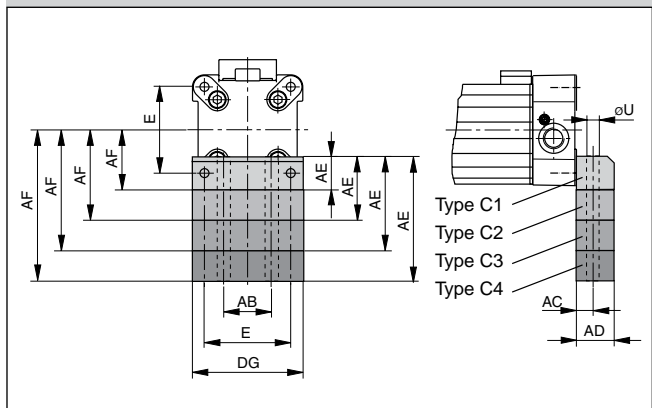

Dimension Table (mm)
– Dimensions AE and AF (Dependent on the mounting type)

Mount. type	Dimensions AE for size								AF for size							
	16	25	32	40	50	63	80	16	25	32	40	50	63	80		
A1	12.5	18	20	-	-	-	-	15	22	30	-	-	-	-		
A2	27.5	33	34	-	-	-	-	30	37	44	-	-	-	-		
A3	-	45	42	-	-	-	-	-	49	52	-	-	-	-		
B1	-	42	55	-	-	-	-	-	22	30	-	-	-	-		
B3	55	-	-	-	-	-	-	42	-	-	-	-	-	-		
B4	-	80	85	-	-	-	-	-	60	60	-	-	-	-		
B5	-	-	90	-	-	-	-	-	-	65	-	-	-	-		
C1	-	-	-	24	30	40	50	-	-	-	38	48	57	72		
C2	-	-	-	37	39	-	-	-	-	-	51	57	-	-		
C3	-	-	-	46	54	76	88	-	-	-	60	72	93	110		
C4	-	-	-	56	77	-	-	-	-	-	70	95	-	-		

Dimension Table (mm)

Series	E	øU	AB	AC	AD	CL	DG
OSP-P16	18	3.6	18	10	14	1.6	26
OSP-P25	27	5.8	27	16	22	2.5	39
OSP-P32	36	6.6	36	18	26	3	50
OSP-P40	54	9	30	12.5	24	-	68
OSP-P50	70	9	40	12.5	24	-	86
OSP-P63	78	11	48	15	30	-	104
OSP-P80	96	14	60	17.5	35	-	130

B



Series OSP-P16 to 80: Type E
(Mounting from above / below using a cap screw)

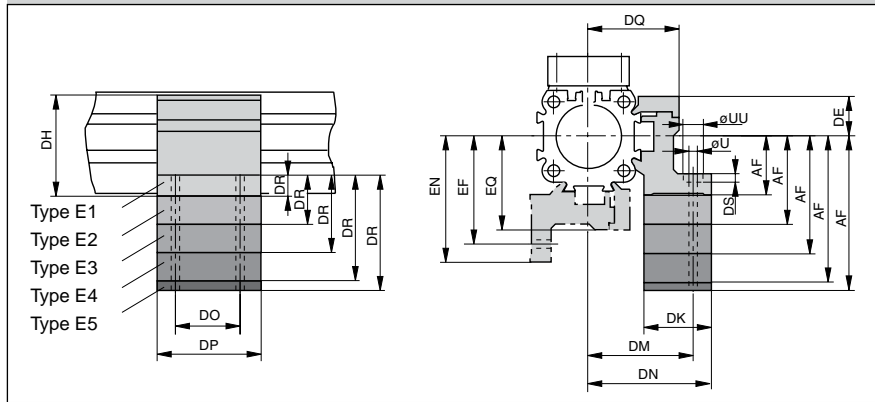

Mid-Section Support

Information regarding type E1 and D1:
Mounting of the Mid-Section supports is also possible on the lower side of the drive. In this case, please note the new center line dimensions.
Stainless steel version on request.



B

Series OSP-P16 to 80: Type D1
(Mounting from below with thread screw)

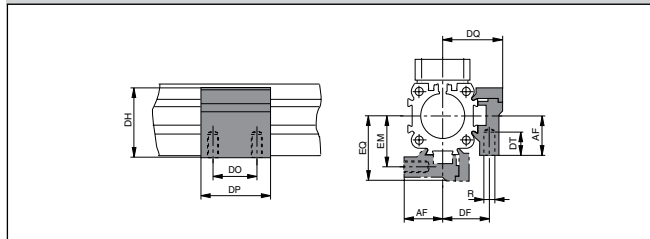

Dimension Table (mm)
– Dimensions AF and DR (Dependent on the mounting type)

Mount. type	Dimensions DR for size							Dimensions AF for size						
	16	25	32	40	50	63	80	16	25	32	40	50	63	80
D1	-	-	-	-	-	-	-	15	22	30	38	48	57	72
E1	6	8	10	10	10	12	15	15	22	30	38	48	57	72
E2	21	23	24	23	19	-	-	30	37	44	51	57	-	-
E3	33	35	32	32	34	48	53	42	49	52	60	72	93	110
E4	-	46	40	42	57	-	-	-	60	60	70	95	-	-
E5	-	-	45	-	-	-	-	-	-	65	-	-	-	-

Dimension Table (mm)

Series	R	U	UU	DE	DF	DH	DK	DM	DN	DO	DP	DQ	DS	DT	EF	EM	EN	EQ
OSP-P16	M3	3.4	6	14.2	20	29.2	24	32	36.4	18	30	27	3.4	6.5	32	20	36.4	27
OSP-P25	M5	5.5	10	16	27	38	26	40	47.5	36	50	34.5	5.7	10	41.5	28.5	49	36
OSP-P32	M5	5.5	10	16	33	46	27	46	54.5	36	50	40.5	5.7	10	48.5	35.5	57	43
OSP-P40	M6	7	-	23	35	61	34	53	60	45	60	45	-	11	56	38	63	48
OSP-P50	M6	7	-	23	40	71	34	59	67	45	60	52	-	11	64	45	72	57
OSP-P63	M8	9	-	34	47.5	91	44	73	83	45	65	63	-	16	79	53.5	89	69
OSP-P80	M10	11	-	39.5	60	111.5	63	97	112	55	80	81	-	25	103	66	118	87

Ordering information for mountings Type A – Type B – Type C – Type D – Type E

Mounting type (versions)	Order No.						
	size						
	16	25	32	40	50	63	80
A1 *)	20408	2010	3010	-	-	-	-
A2 *)	20464	2040	3040	-	-	-	-
A3 *)	-	2060	3060	-	-	-	-
B1 *)	-	20311	20313	-	-	-	-
B3 *)	20465	-	-	-	-	-	-
B4 *)	-	20312	20314	-	-	-	-
B5 *)	-	-	20976	-	-	-	-
C1 *)	-	-	-	4010	5010	6010	8010
C2 *)	-	-	-	20338	20349	-	-
C3 *)	-	-	-	20339	20350	20821	20822
C4 *)	-	-	-	20340	20351	-	-
D1	20434	20008	20157	20027	20162	20451	20480
E1	20435	20009	20158	20028	20163	20452	20482
E2	20436	20352	20355	20358	20361	-	-
E3	20437	20353	20356	20359	20362	20453	20819
E4	-	20354	20357	20360	20363	-	-
E5	-	-	20977	-	-	-	-

(* Pair)

Ordering Instructions / Part Numbering System for OSP-P POWERSLIDE Series

B

6	7	8	9	10	11	12-16	17	18	19	20	21	22	23	24	25	
OSPP	32	0	0	0	0	S	02500	0	0	0	G	0	0	2	0	0
	Bore 16 25 32 40 50		Seals 0 Standard 1 Viton S Special			Stroke x x x x x		Cushioning / Stops 0 Standard S Special		Piston Mountings 0 none		Dovetail Cover 0 Standard X Without Cover Rail S Special		Version Switches / Measuring System 0 none 1 NO Reed-KL3045 Qty: 2 2 NC Reed-KL3048 Qty: 2 3 PNP KL3054+4041 Qty: 2 4 NPN KL3060+4041 Qty: 2 X 21240 SFI 0,1mm Y 21241 SFI 1mm Z 4650 SFA S Special		
	Piston Style 0 Standard 1 Tandem S Special		Lubrication 0 Standard 1 Slow Speed 4 Food 5 Clean Room S Special					Guides / Brakes E PSXX/25 Powerslide (16,25) F PSXX/35 Powerslide (25,32) G PSXX/44 Powerslide (25,32,40) H PSXX/60 Powerslide (40,50) I PSXX/76 Powerslide (50)				End Cap Mounts 0 without 1 A1 (16,25,32) 2 A2 (16,25,32) 3 A3 (25,32) 4 B1 (25,32) 6 B3 (16) 7 B4 (25,32) 8 B5 (32) 9 C1 (40,50) A C2 (40,50) B C3 (40,50) C C4 (40,50)				
	Air Connections / Porting 0 Standard (position #2) 1 end face (position #5) 2 single end porting 3 left stand (pos #2), right end face (pos#5) 4 right stand (pos #2), left end face (pos #5) 6 single end porting end face A 3/2 Way valve VOE 24V = (25,32,40,50) B 3/2 Way valve VOE 220V~/110V= (25,32,40,50) C 3/2 Way valve VOE 48V=(25,32,40,50) E 3/2 Way valve VOE 110V~ (25,32,40,50) S Special		Corrosion Resist. Hardware 0 Standard 1 Stainless S Special		End Cap Position 0 l+r 0° = in front (pos #2) 1 l+r 90° = underneath (pos #3) 2 l+r 180° = at the back (pos #4) 3 l+r 270° = same face as outerband (pos #2,1) 4 l 90° = underneath; r 0° = in front (pos #3,2) 5 l 180° = at the back; r 0° = in front (pos #4,2) 6 l 270° = same face as outerband; r 0° = in front (pos #1,2) 7 l 0° = in front; r 90° = underneath (pos #2, 3) 8 l 180° = at the back; r 90° = underneath (pos #4,3) 9 l 270° = same face as outerband; r 90° = underneath (pos #1,3) A l 0° = in front; r 180° = at the back (pos #2,4) B l 90° = underneath; r 180° = at the back (pos #3,4) C l 270° = same face as outerband; r 180° = at the back (pos #1,4) D l 0° = in front; r 270° = same face as outerband (pos #2,1) E l 90° = underneath; r 270° = same face as outerband (pos #3,1) F l 180° = at the back; r 270° = same face as outerband (pos #4,1) S Special							add. Carriage 0 without E Guide Carriage Powerslide PSXX/25 (16,25) F Guide Carriage Powerslide PSXX/35 (25,32) G Guide Carriage Powerslide PSXX/44 (25,32,40) H Guide Carriage Powerslide PSXX/60 (40,50)				

Note: Single End Porting on 16mm bore, then end caps cannot be rotated.

Note: Comes in pairs

Note: 2 switches will be supplied. For different quantity, please order as a separate line item.

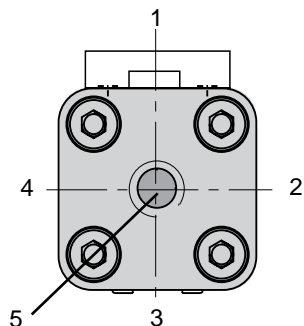

Note: Position #2 is the standard location.



Versions

for pneumatic linear drive:
Series OSP-P

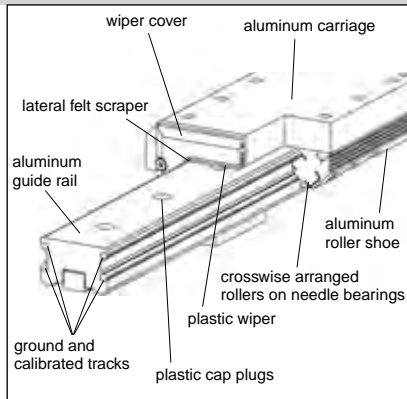

Aluminum Roller Guide PROLINE



**Series PL 16 to 50
 for Linear-drive
 • Series OSP-P**

Technical Data

The table shows the maximal permissible loads. If multiple moments and forces act upon the cylinder simultaneously, the following equation applies:

$$\frac{M_x}{M_{x_{max}}} + \frac{M_y}{M_{y_{max}}} + \frac{M_z}{M_{z_{max}}} + \frac{F_y}{F_{y_{max}}} + \frac{F_z}{F_{z_{max}}} \leq 1$$

The sum of the loads should not exceed >1.
 With a load factor of less than 1, service life is 8000 km

The table shows the maximum permissible values for light, shock-free operation, which must not be exceeded even under dynamic conditions.

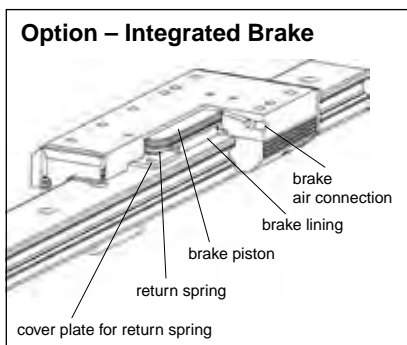

Features:

- High precision
- High velocities (10 m/s)
- Smooth operation - low noise
- Integrated wiper system
- Long life lubrication
- Compact dimensions - compatible to Slideline plain bearing guide
- Any length of stroke up to 3750 mm

**Integrated Brake (optional)
 for Series OSP-P25 to OSP-P50:**

- Actuated by pressurization
- Release by depressurization and spring actuation

Loads, Forces and Moments

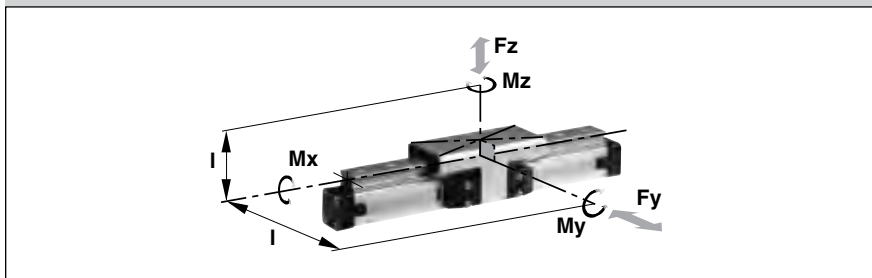

*** Please note:**

The mass of the carriage has to be added to the total moving mass when using the cushioning diagram.

Series	For linear drive	Max. moments (Nm)			Max. loads (N) Fy, Fz	Maximum braking force at 6 bar (N) ¹⁾	Mass of linear drive with guide (kg)		Mass* guide carriage (kg)
		Mx	My	Mz			with 0 mm stroke	increase per 100 mm stroke	
PL 16	OSP-P16	8	12	12	542	-	0.55	0.19	0.24
PL 25	OSP-P25	16	39	39	857	on request	1.65	0.40	0.75
PL 32	OSP-P32	29	73	73	1171	on request	3.24	0.62	1.18
PL 40	OSP-P40	57	158	158	2074	on request	4.35	0.70	1.70
PL 50	OSP-P50	111	249	249	3111	on request	7.03	0.95	2.50

¹⁾ Only for version with brake:

Braking surface dry – oiled surface reduces the effective braking force.



Dimensions & Technical Data

Dimension Table (mm) Series OSP-P PL16, PL25, PL32, PL40, PL50

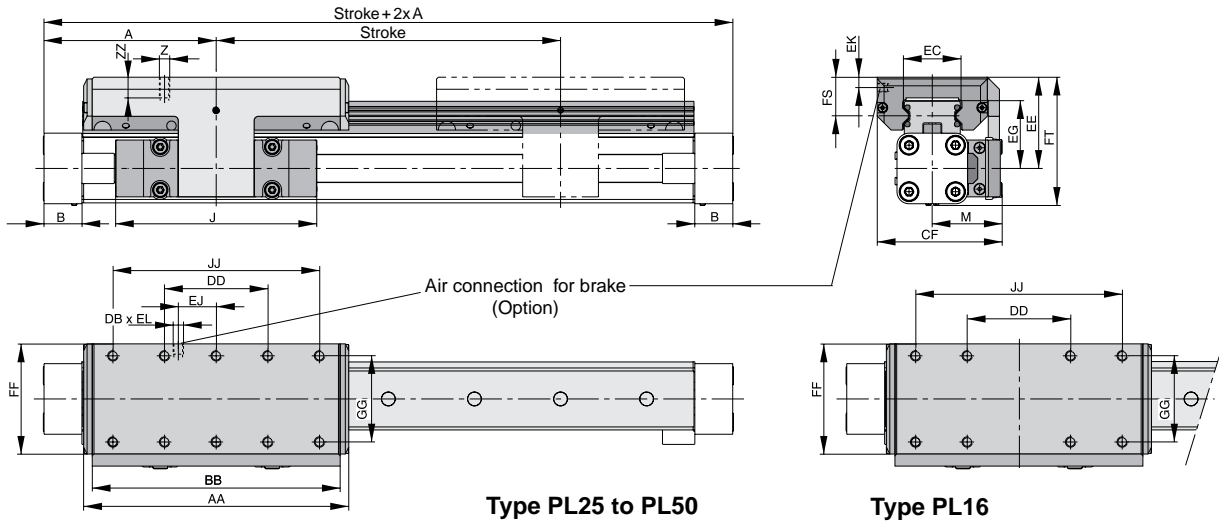

B

Dimension Table (mm) Series OSP-P PL16, PL25, PL32, PL40, PL50

Series	A	B	J	M	Z	AA	BB	DB	DD	CF	EC	EE	EG	EJ	EK	EL	FF	FS	FT	GG	JJ	ZZ
PL16	65	14	69	31	M4	98	88	-	30	55	23	40	30	-	-	-	48	17	55	36	70	8
PL25	100	22	117	40.5	M6	154	144	M5	60	72.5	32.5	53	39	22	6	6	64	23	73.5	50	120	12
PL32	125	25.5	152	49	M6	197	187	M5	80	91	42	62	48	32	6	6	84	25	88	64	160	12
PL40	150	28	152	55	M6	232	222	M5	100	102	47	64	50.5	58	6	6	94	23.5	98.5	78	200	12
PL50	175	33	200	62	M6	276	266	M5	120	117	63	75	57	81	6	6	110	29	118.5	90	240	16

Mid-Section Support

(For versions, see page B64)
 Mid-section supports are required from a certain stroke length to prevent excessive deflection and vibration of the linear drive. The diagrams show the maximum permissible unsupported length in relation to loading. A distinction must be drawn between loading 1 and loading 2. Deflection of 0.5 mm max. between supports is permissible.

Note:

For speeds $v > 0.5$ m/s the distance between supports should not exceed 1 m.

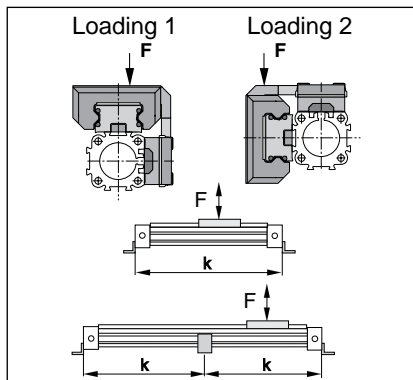

Permissible Unsupported Length PL16, PL25, PL32, PL40 and PL50

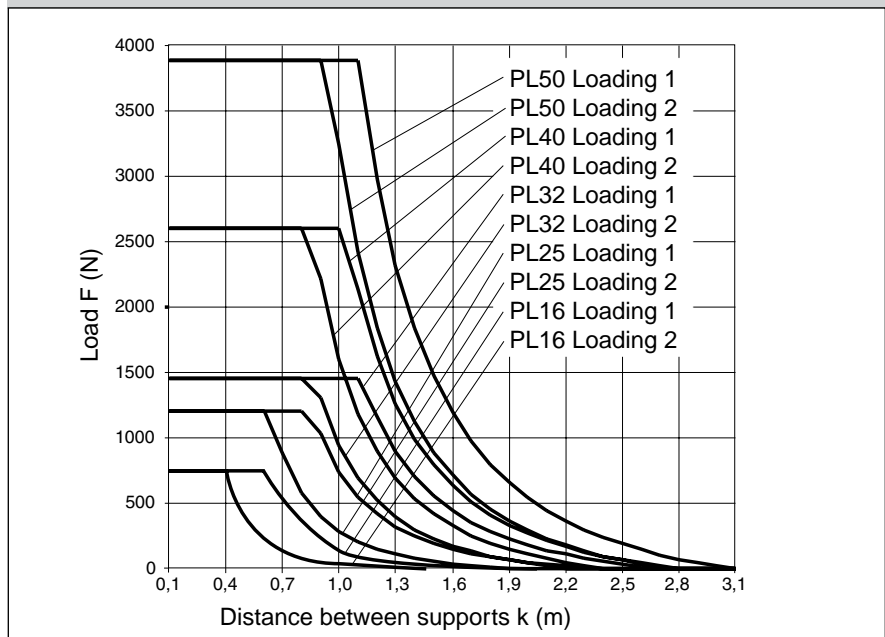

Features & Ordering Information

Versions

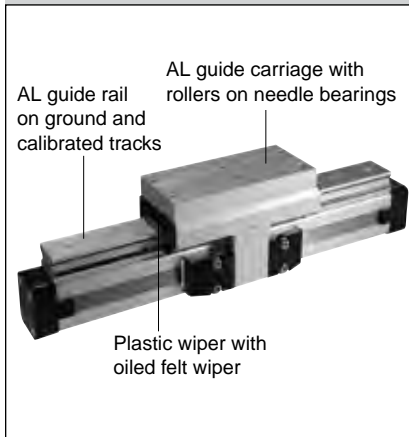

Function

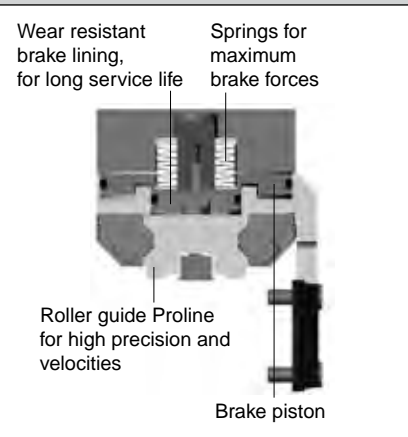

Multi-Brake Passive Brake with Aluminum Roller Guide Proline PL



Series MB-PL 25 to 50
for Linear-drive
• Series OSP-P

B

Function:

The Multi-Brake is a passive device. When the air pressure is removed the brake is actuated and movement of the cylinder is blocked. The brake is released by pressurization.

The high friction, wear resistant brake linings allow the Multi-Brake to be used as a dynamic brake to stop cylinder movement in the shortest possible time. The powerful springs also allow the Multi-Brake to be used effectively in positioning applications.

Features:

- Brake operated by spring actuation
- Brake release by pressurization
- Optional sensor to indicate brake lining wear
- Composite sealing system with plastic and felt wiper elements to remove dirt and lubricate the slideway
- Blocking function in case of pressure loss
- Intermediate stops possible

¹⁾ Braking surface dry – oil on the braking surface will reduce the braking force

* Please note:

In the cushioning diagram, the mass of the guide carriage has to be added to the total moving mass.

Loads, Forces and Moments

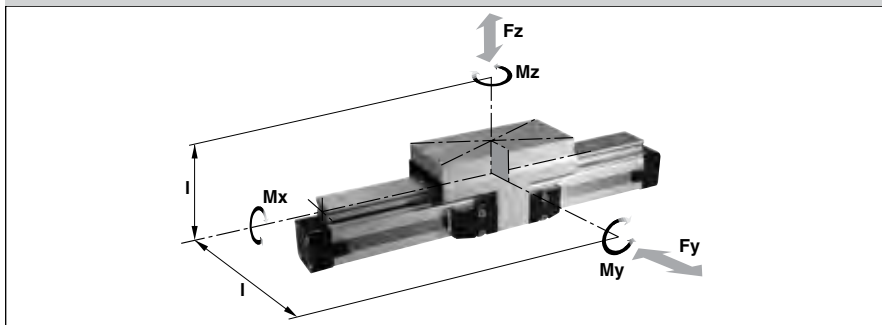

Technical Data

The table shows the maximal permissible loads. If multiple moments and forces act upon the cylinder simultaneously, the following equation applies:

$$\frac{M_x}{M_{x_{max}}} + \frac{M_y}{M_{y_{max}}} + \frac{M_z}{M_{z_{max}}} + \frac{L_y}{L_{y_{max}}} + \frac{L_z}{L_{z_{max}}} \leq 1$$

The sum of the loads should not exceed >1. With a load factor of less than 1, service life is 8000 km

The table shows the maximum permissible values for light, shock-free operation, which must not be exceeded even under dynamic conditions. Operating Pressure 4.5 - 8 bar. A pressure of min. 4.5 bar release the brake.

Series	For linear drive	Max. moments (Nm)			Max. loads (N) F _y , F _z	Max. brake force (N) ¹⁾	Mass of linear drive with guide (kg)		Mass* guide carriage (kg)
		M _x	M _y	M _z			with 0 mm stroke	increase per 100 mm stroke	
MB-PL25	OSP-P25	16	39	39	857	315	2.14	0.40	1.24
MB-PL32	OSP-P32	29	73	73	1171	490	4.08	0.62	2.02
MB-PL40	OSP-P40	57	158	158	2074	715	5.46	0.70	2.82
MB-PL50	OSP-P50	111	249	249	3111	1100	8.60	0.95	4.07



Dimensions & Technical Data

Series OSP-P with Passive Brake MB-PL

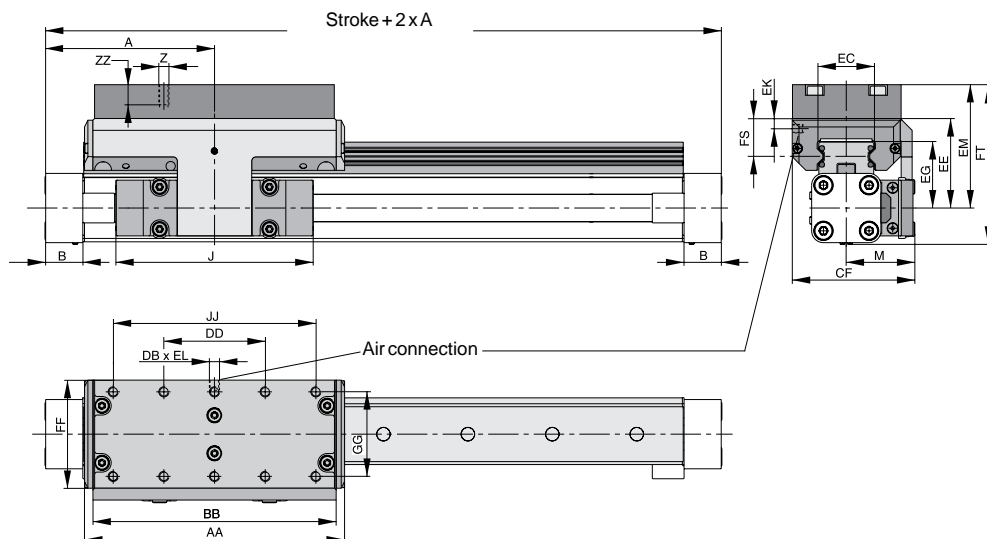

B

Dimension Table (mm) Series OSP-P MB-PL25, MB-PL32, MB-PL40, MB-PL50

Series	A	B	J	M	Z	AA	BB	DB	DD	CF	EC	EE	EG	EK	EL	EM	FF	FS	FT	GG	JJ	ZZ
MB-PL25	100	22	117	40.5	M6	154	144	M5	60	72.5	32.5	53	39	9	5	73	64	23	93.5	50	120	12
MB-PL32	125	25.5	152	49	M6	197	187	G1/8	80	91	42	62	48	7	10	82	84	25	108	64	160	12
MB-PL40	150	28	152	55	M6	232	222	G1/8	100	102	47	64	50.5	6.5	10	84	94	23.5	118.5	78	200	12
MB-PL50	175	33	200	62	M6	276	266	G1/8	120	117	63	75	57	10	12	95	110	29	138.5	90	240	16

Mid Section Support

(for versions see page B66)

Mid-Section supports are required from a certain stroke length to prevent excessive deflection and vibration of the linear drive. The diagrams show the maximum permissible unsupported length in relation to loading.

A distinction must be drawn between loading 1 and loading 2. Deflection of 0.5 mm max. between supports is permissible.

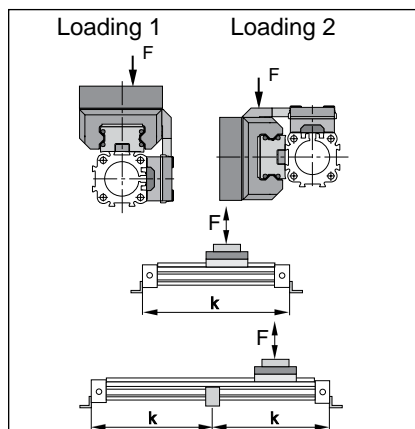

Note:

For speeds $v > 0.5$ m/s the distance between supports should not exceed 1 m.

Permissible Unsupported Length OSP-P MB-PL25, MB-PL32, MB-PL40, MB-PL50

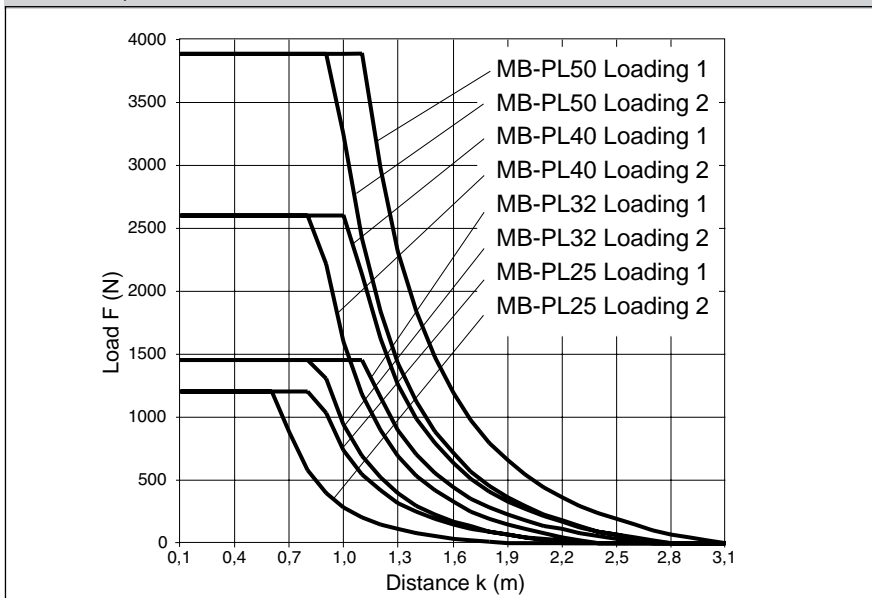

B

Application Example - Vertical Application

Control of a cylinder with 3/2 way valves. Basic position – **exhausted**

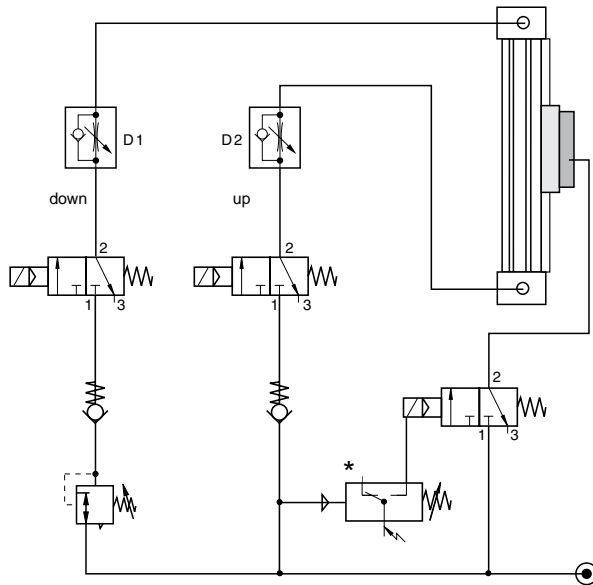

Control of a cylinder with 3/2 way valves. Basic position – **pressurized**

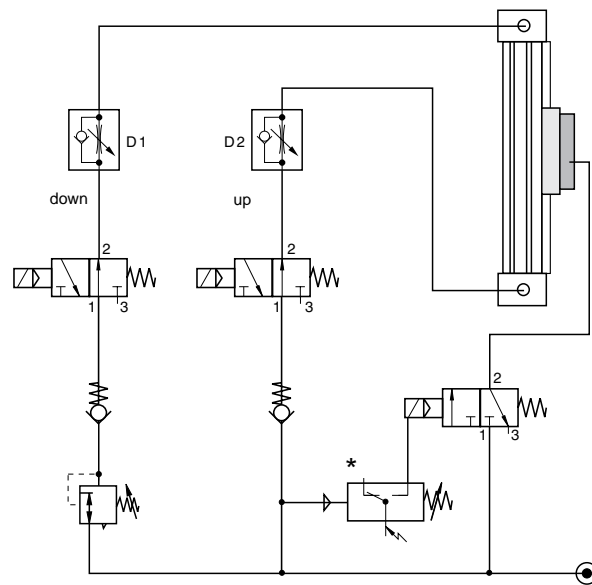

Control Examples

Under normal operating circumstances the pressure switch is closed and the air flows through the 3/2 way solenoid valves from port 1 to 2, thus lifting the brake from the rail (operating condition).

The brake is pressurized by means of a 3/2 way valve in combination with a pressure switch. When there is a pressure loss, the brake is actuated by the pressure switch.

When the air pressure is restored to both cylinder chambers, the brake is lifted and the linear drive can be moved again.

The speed regulating valves D1 and D2 control the speed of the linear drive, and have no influence on the brake. The two non-return valves give the system a higher stability.

The pressure regulating valve is used to compensate for the downward force in this vertical application.

Please note:



Before the brake is lifted, make sure that both air chambers of the linear drive are pressurized.

Small diameter tubing, fittings and valves with a nominal diameter, and tubing that is too long all change the reaction time of the brake!

Tip:

The pressure switch actuates the brake when the pressure drops below the set value.

Required Components

Way Valves
Port size
M5, G1/8
G1/4, G1/2
Pressure Regulating Valves
G1/8 - G3/8
Pneumatic Accessories
P/E-Switch
Non-Return Valves
G1/8 - G3/8
Screw-in Speed Regulating Valves
M5 - G1/4

Contact factory for literature on the above valves/accessories





Linear Drive Accessories

Mountings for Linear Drives fitted with OSP-Guides

B



For Linear-drives
 • Series OSP-P

Overview		Type – OSP Guides																	
Mounting Type	Type	SLIDELINE PROLINE MULTIBRAKE							POWERSLIDE										
		16 ¹⁾	25	32	40	50	63 ¹⁾	80 ¹⁾	16/25	25/25	25/35	25/44	32/35	32/44	40/44	40/60	50/60	50/76	
End cap mounting 	Type A1	X							X										
	Type A2	O	O	O															
	Type A3									O	O		O						
End cap mounting, reinforced 	Type B1		X	X						X	X	X	X	X					
	Type B3								O										
	Type B4											O		O					
	Type B5																		
End cap mounting 	Type C1				X	X	X	X								X	X	X	X
	Type C2				O	O													
	Type C3						O	O								O		O	
	Type C4																O		O
Mid-Section support, small Mid-Section support, wide 	Type D1	X	X	X	X	X	X	X	X	X	X	X	X	X	X	X	X	X	X
	Type E1	X	X	X	X	X	X	X	X	X	X	X	X	X	X	X	X	X	X
	Type E2	O	O	O	O	O													
	Type E3						O	O	O	O	O		O		O		O		O
	Type E4											O		O		O		O	
	Type E5																		



- X = carriage mounted in top (12 o'clock position)
- O = carriage mounted in lateral (3 or 9 o'clock position)
- = available components

1) = not available for all sizes

Series OSP-P16,25,32:Type A

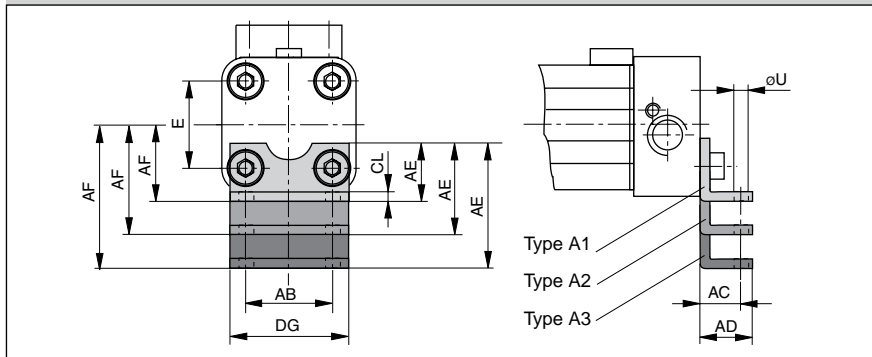

End Cap Mountings

Four internal screw threads are located in the end faces of all OSP actuators for mounting the drive unit. End cap mountings may be secured across any two adjacent screws.

Material:

Series OSP-16, 25, 32:
Galvanized steel

Series OSP-40,50, 63, 80:
Anodized aluminum

The mountings are supplied in pairs.

Series OSP-P16,25,32:Type B

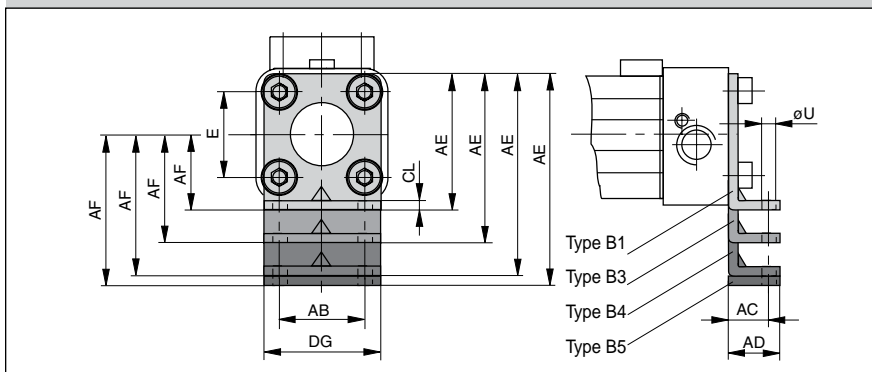

Series OSP-P40,50,63,80:Type C

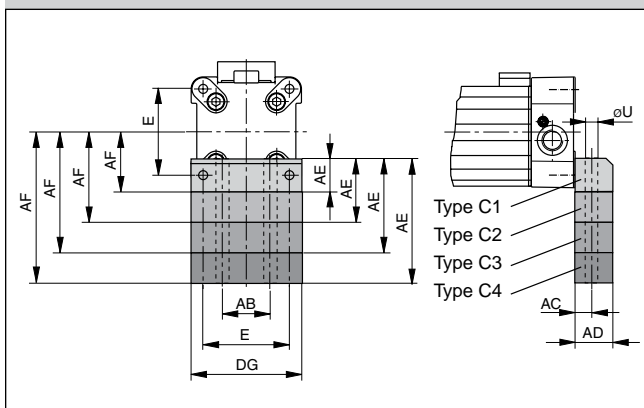

Dimension Table (mm)
– Dimensions AE and AF (Dependent on the mounting type)

Mount. type	Dimensions AE for size								AF for size							
	16	25	32	40	50	63	80	16	25	32	40	50	63	80		
A1	12.5	18	20	-	-	-	-	15	22	30	-	-	-	-		
A2	27.5	33	34	-	-	-	-	30	37	44	-	-	-	-		
A3	-	45	42	-	-	-	-	-	49	52	-	-	-	-		
B1	-	42	55	-	-	-	-	22	30	-	-	-	-	-		
B3	55	-	-	-	-	-	-	42	-	-	-	-	-	-		
B4	-	80	85	-	-	-	-	60	60	-	-	-	-	-		
B5	-	-	90	-	-	-	-	-	65	-	-	-	-	-		
C1	-	-	-	24	30	40	50	-	-	-	38	48	57	72		
C2	-	-	-	37	39	-	-	-	-	-	51	57	-	-		
C3	-	-	-	46	54	76	88	-	-	-	60	72	93	110		
C4	-	-	-	56	77	-	-	-	-	-	70	95	-	-		

Dimension Table (mm)

Series	E	øU	AB	AC	AD	CL	DG
OSP-P16	18	3.6	18	10	14	1.6	26
OSP-P25	27	5.8	27	16	22	2.5	39
OSP-P32	36	6.6	36	18	26	3	50
OSP-P40	54	9	30	12.5	24	-	68
OSP-P50	70	9	40	12.5	24	-	86
OSP-P63	78	11	48	15	30	-	104
OSP-P80	96	14	60	17.5	35	-	130



Mid-Section Support

Mid-Section Support

Information regarding type E1 and D1:
Mounting of the Mid-Section supports is also possible on the lower side of the drive. In this case, please note the new center line dimensions.
Stainless steel version on request.



Series OSP-P16 to 80: Type E
(Mounting from above / below using a cap screw)

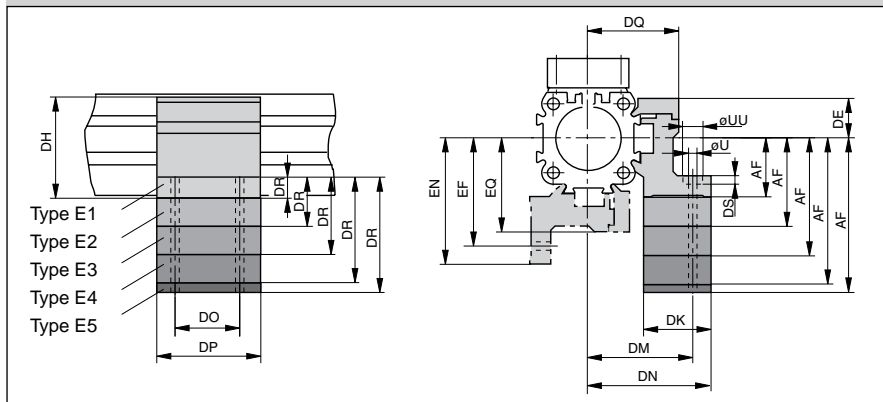

B

Dimension Table (mm)
– Dimensions AF and DR (Dependent on the mounting type)

Mount. type	Dimensions DR for size								Dimensions AF for size							
	16	25	32	40	50	63	80	16	25	32	40	50	63	80		
D1	-	-	-	-	-	-	-	15	22	30	38	48	57	72		
E1	6	8	10	10	10	12	15	15	22	30	38	48	57	72		
E2	21	23	24	23	19	-	-	30	37	44	51	57	-	-		
E3	33	35	32	32	34	48	53	42	49	52	60	72	93	110		
E4	-	46	40	42	57	-	-	60	60	70	95	-	-	-		
E5	-	-	45	-	-	-	-	-	65	-	-	-	-	-		

Series OSP-P16 to 80: Type D1
(Mounting from below with thread screw)

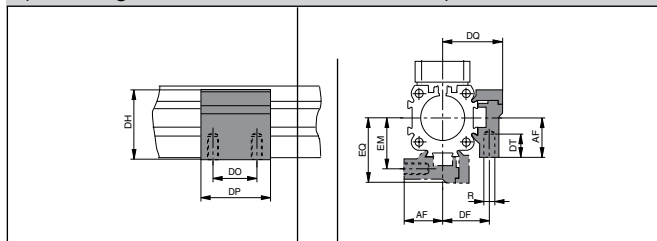

Dimension Table (mm)

Series	R	U	UU	DE	DF	DH	DK	DM	DN	DO	DP	DQ	DS	DT	EF	EM	EN	EQ
OSP-P16	M3	3.4	6	14.2	20	29.2	24	32	36.4	18	30	27	3.4	6.5	32	20	36.4	27
OSP-P25	M5	5.5	10	16	27	38	26	40	47.5	36	50	34.5	5.7	10	41.5	28.5	49	36
OSP-P32	M5	5.5	10	16	33	46	27	46	54.5	36	50	40.5	5.7	10	48.5	35.5	57	43
OSP-P40	M6	7	-	23	35	61	34	53	60	45	60	45	-	11	56	38	63	48
OSP-P50	M6	7	-	23	40	71	34	59	67	45	60	52	-	11	64	45	72	57
OSP-P63	M8	9	-	34	47.5	91	44	73	83	45	65	63	-	16	79	53.5	89	69
OSP-P80	M10	11	-	39.5	60	111.5	63	97	112	55	80	81	-	25	103	66	118	87

Ordering information for mountings Type A – Type B – Type C – Type D – Type E

Mounting type (versions)	Order No.						
	size						
	16	25	32	40	50	63	80
A1*)	20408	2010	3010	-	-	-	-
A2*)	20464	2040	3040	-	-	-	-
A3*)	-	2060	3060	-	-	-	-
B1*)	-	20311	20313	-	-	-	-
B3*)	20465	-	-	-	-	-	-
B4*)	-	20312	20314	-	-	-	-
B5*)	-	-	20976	-	-	-	-
C1*)	-	-	-	4010	5010	6010	8010
C2*)	-	-	-	20338	20349	-	-
C3*)	-	-	-	20339	20350	20821	20822
C4*)	-	-	-	20340	20351	-	-
D1	20434	20008	20157	20027	20162	20451	20480
E1	20435	20009	20158	20028	20163	20452	20482
E2	20436	20352	20355	20358	20361	-	-
E3	20437	20353	20356	20359	20362	20453	20819
E4	-	20354	20357	20360	20363	-	-
E5	-	-	20977	-	-	-	-

(* Pair)



Ordering Instructions / Part Numbering System for OSP-P PROLINE Series

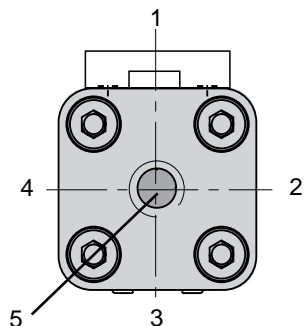
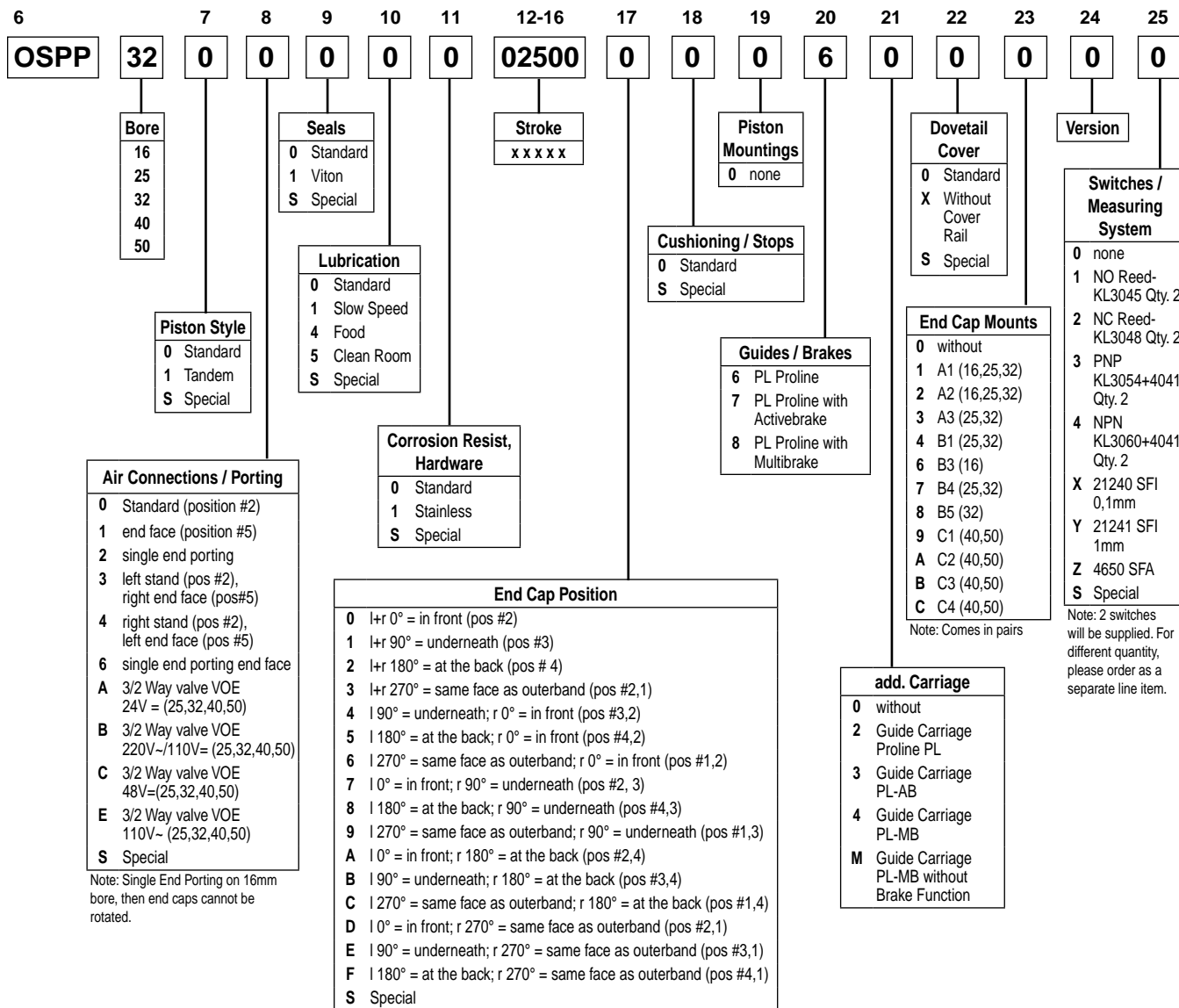

Note: Position #2 is the standard location.



Recirculating Ball Bearing Guide STARLINE

B



Series STL 16 to 50
 for Linear Drive Series OSP-P

Features:

- Polished and hardened steel guide rail
 - For very high loads in all directions
 - High precision
 - Integrated wiper system
 - Integrated grease nipples
 - Any length of stroke up to 3700 mm
 - Anodized aluminum guide carriage – dimensions compatible with OSP guides SLIDELINE and PROLINE
 - Installation height (STL16 - 32) compatible with OSP guides SLIDELINE and PROLINE
- Maximum speed
 STL16: v = 3 m/s
 STL25 to 50: v = 5 m/s

**** Please note:**

The mass of the carriage has to be added to the total moving mass when using the cushioning diagram.

Versions

for pneumatic linear drive:
 Series OSP-P

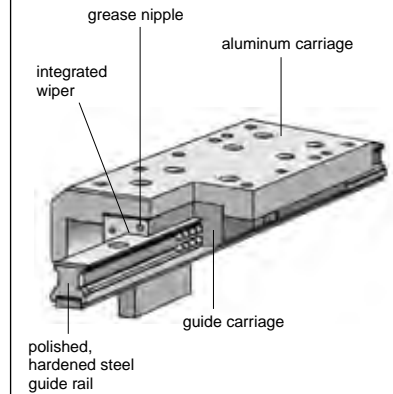

Loads, Forces and Moments

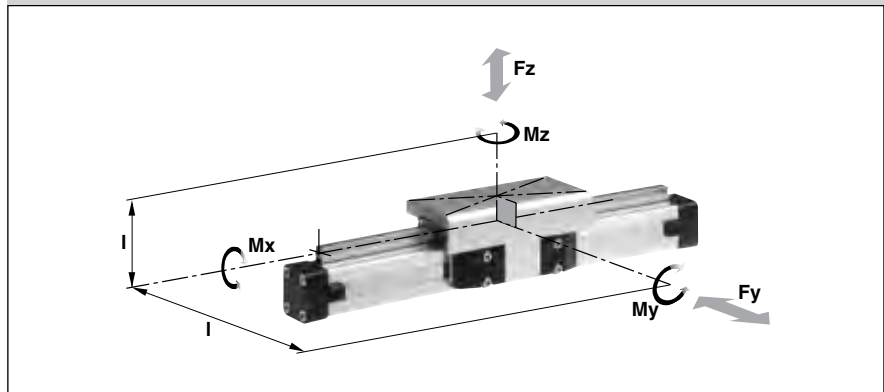

Technical Data

The table shows the maximum permissible loads. If multiple moments and forces act upon the cylinder simultaneously, the following equation applies:

$$\frac{M_x}{M_{x_{max}}} + \frac{M_y}{M_{y_{max}}} + \frac{M_z}{M_{z_{max}}} + \frac{F_y}{F_{y_{1max}}} + \frac{F_z}{F_{z_{max}}} \leq 1$$

The table shows the maximum permissible values for light, shock-free operation, which must not be exceeded even under dynamic conditions.

The sum of the loads should not exceed >1

Series	For linear drive	Max. moments (Nm)			Max. loads (N)		Mass of linear drive with guide (kg)		Mass ** guide carriage (kg)
		Mx	My	Mz	Fy	Fz	with 0 mm stroke	increase per 100 mm stroke	
STL16	OSP-P16	15	30	30	1000	1000	0.598	0.210	0.268
STL25	OSP-P25	50	110	110	3100	3100	1.733	0.369	0.835
STL32	OSP-P32	62	160	160	3100	3100	2.934	0.526	1.181
STL40	OSP-P40	150	400	400	4000	7500	4.452	0.701	1.901
STL50	OSP-P50	210	580	580	4000	7500	7.361	0.936	2.880

Dimensions Series OSP-P STL16 to STL 50

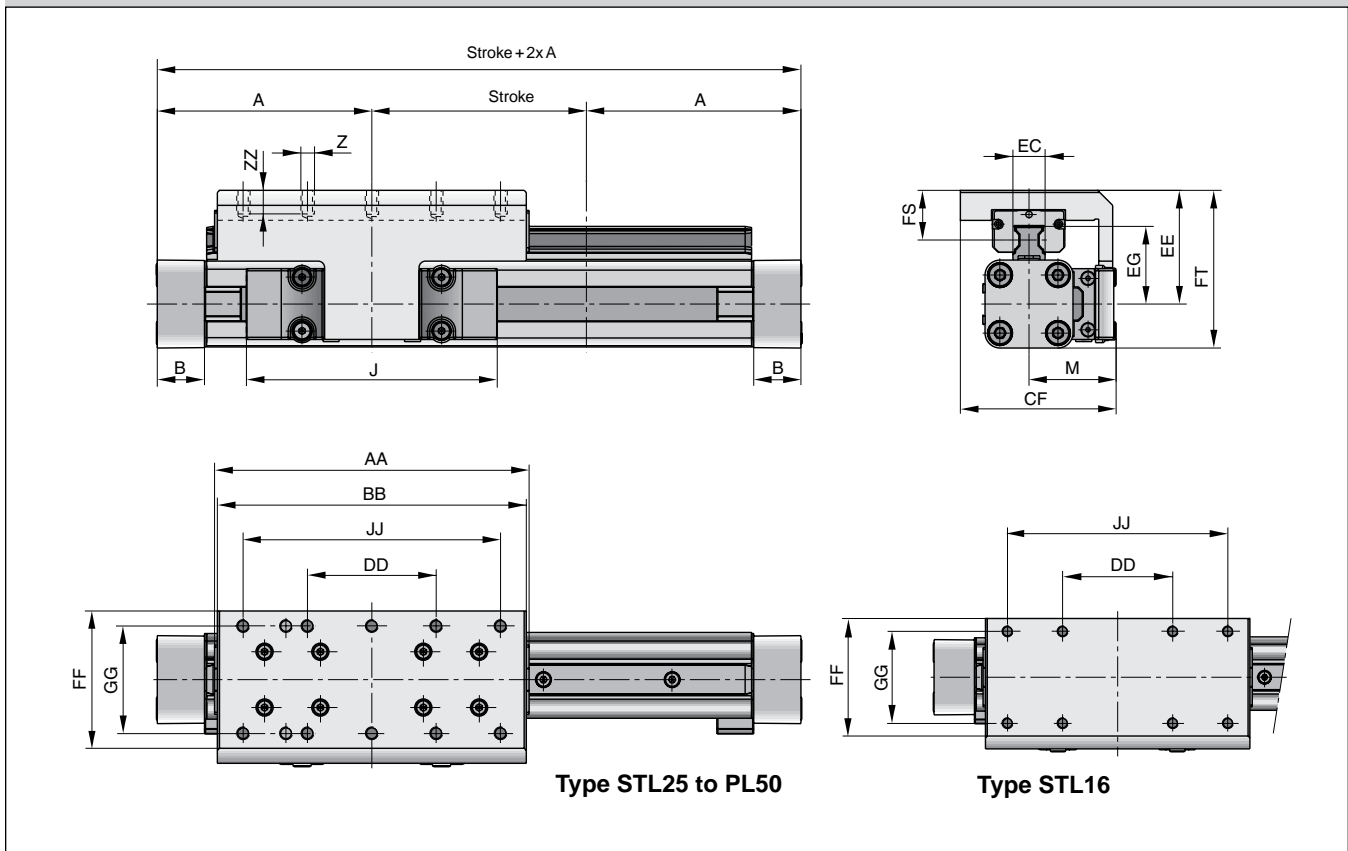

B

Dimension Table (mm) Series OSP-P STL16 to STL50

Series	A	B	J	M	Z	AA	BB	CF	DD	EC	EE	EG	FF	FS	FT	GG	JJ	ZZ
STL16	65	14	69	31	M4	93	90	55	30	15	40	24.6	48	18	55	36	70	8
STL25	100	22	117	40.5	M6	146.6	144	72.5	60	15	53	36.2	64	23.2	73.5	50	120	12
STL32	125	25.5	152	49	M6	186.6	184	91	80	15	62	42.2	84	26.2	88	64	160	12
STL40	150	28	152	55	M6	231	226	102	100	20	72	51.6	94	28.5	106.5	78	200	12
STL50	175	33	200	62	M6	270.9	266	117	120	23	85	62.3	110	32.5	128.5	90	240	16

Mid-Section Support

(For versions, see pages B76-B77)

Mid-section supports are required from a certain stroke length to prevent excessive deflection and vibration of the linear drive. The diagrams show the maximum permissible unsupported length in relation to loading. A distinction must be drawn between loading 1 and loading 2. Deflection of 0.5 mm max. between supports is permissible.

B

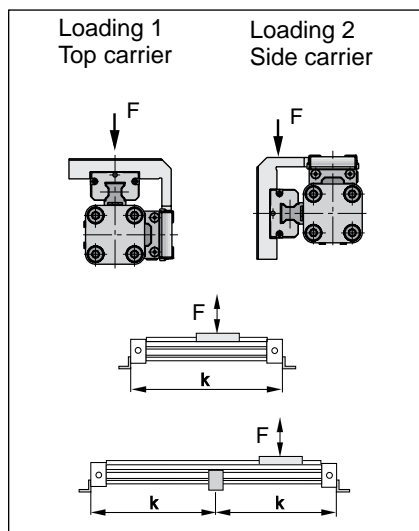

Note:

For speeds $v > 0.5$ m/s the distance between supports should not exceed 1 m.

Permissible Unsupported Length STL16 to STL50

Loading 1 – Top carrier

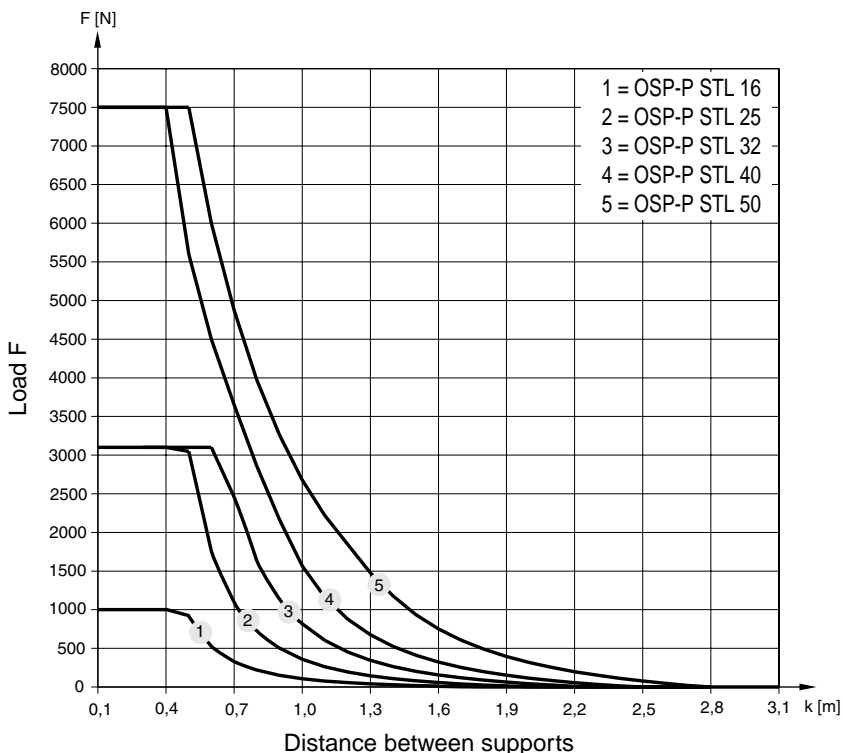

Permissible Unsupported Length STL16 to STL50

Loading 2 – Side carrier

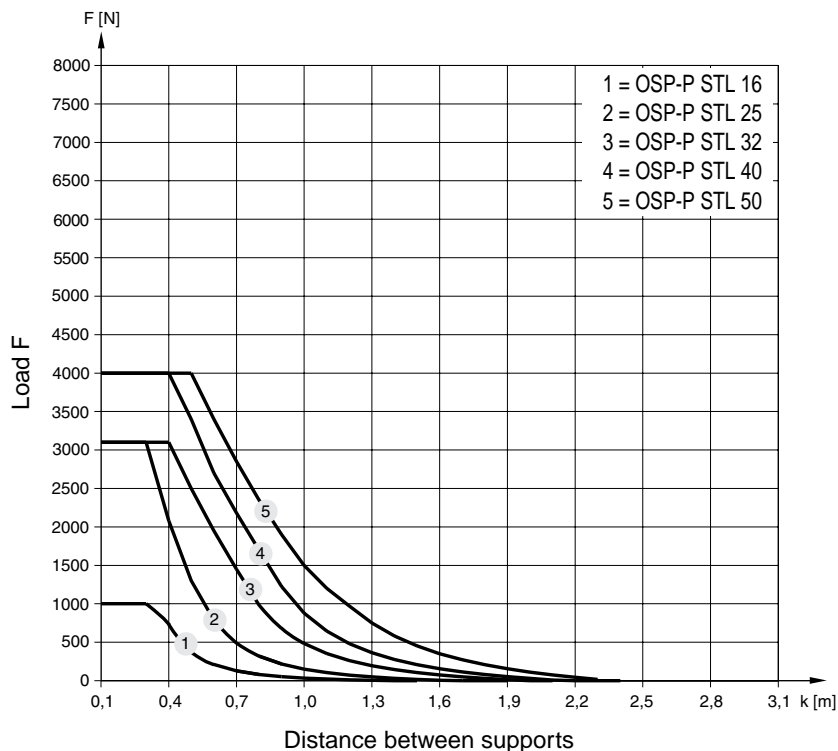

Variable Stop Type VS16 to VS50

Arrangement with two variable stops

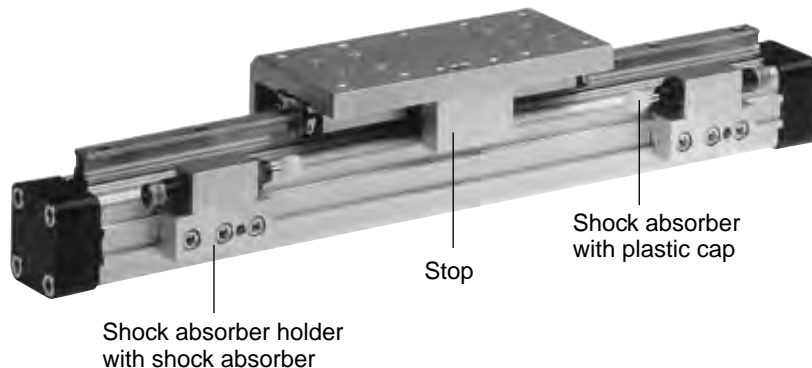

Variable Stop

The variable stop Type VS provides simple stroke limitation.

It can be retrofitted and positioned anywhere along the stroke length.

For every cylinder diameter two types of shock absorber are available

– see “Shock Absorber Selection” below.

Mid-section supports and magnetic switches can still be fitted on the same side as the variable stop.

Depending on the application, two variable stops can be fitted if required.



Shock Absorber Selection in Dependence on Mass and Speed for Series OSP-STL16

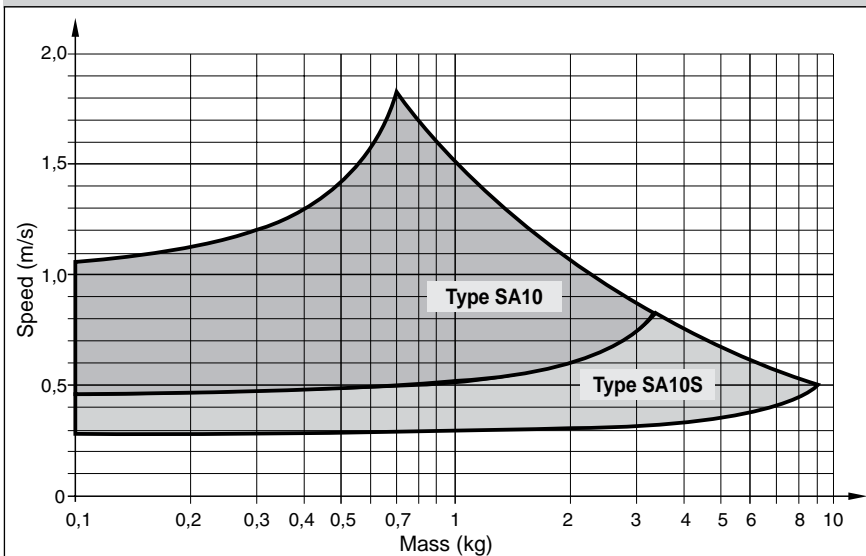

Shock Absorber Selection

The shock absorber is selected in dependence on the mass and speed.

The mass of the carrier itself must be taken into account.

Shock Absorber Selection in Dependence on Mass and Speed for Series OSP-STL25

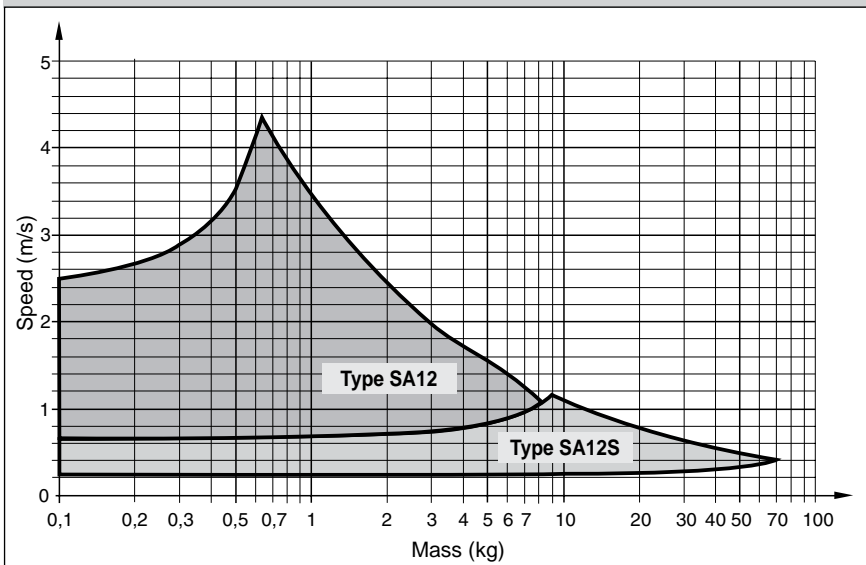

The values relate to an effective driving force of 78 N (6 bar)

The values relate to an effective driving force of 250 N (6 bar)

**Shock Absorber Selection in Dependence on Mass and Speed
 for Series OSP-STL32**

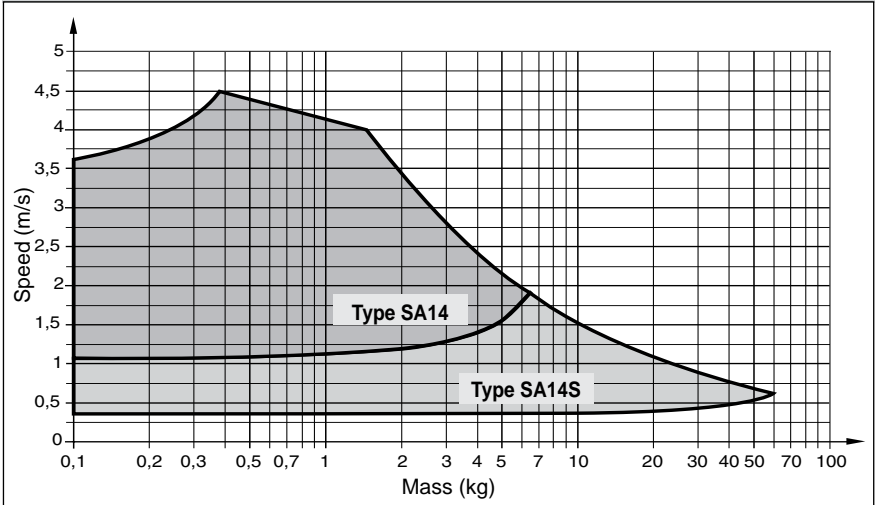

The values relate to an effective driving force of 420 N (6 bar)

**Shock Absorber Selection in Dependence on Mass and Speed
 for Series OSP-STL40**

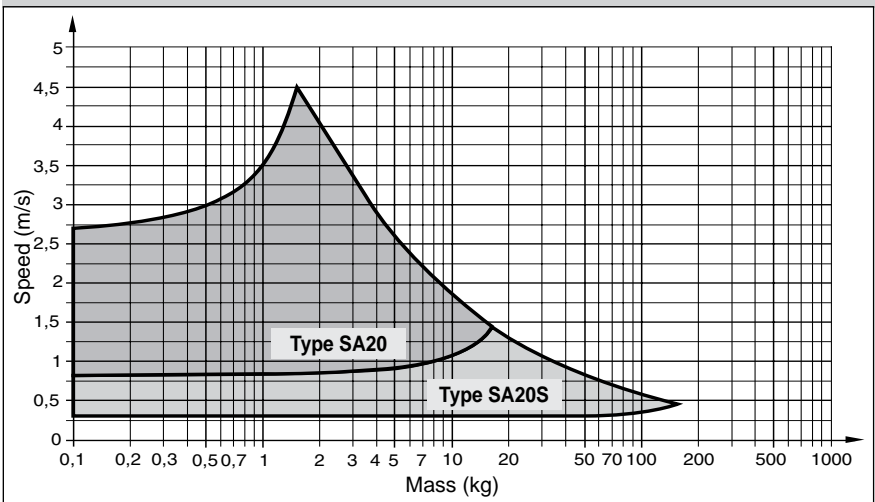

The values relate to an effective driving force of 640 N (6 bar)

**Shock Absorber Selection in Dependence on Mass and Speed
 for Series OSP-STL50**

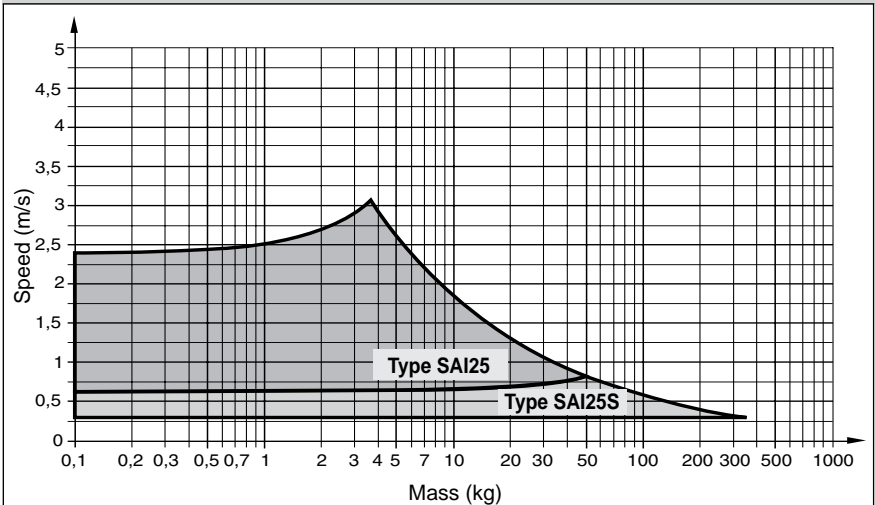

The values relate to an effective driving force of 1000 N (6 bar)

B



Dimensions – Variable Stop Type VS16 to VS50

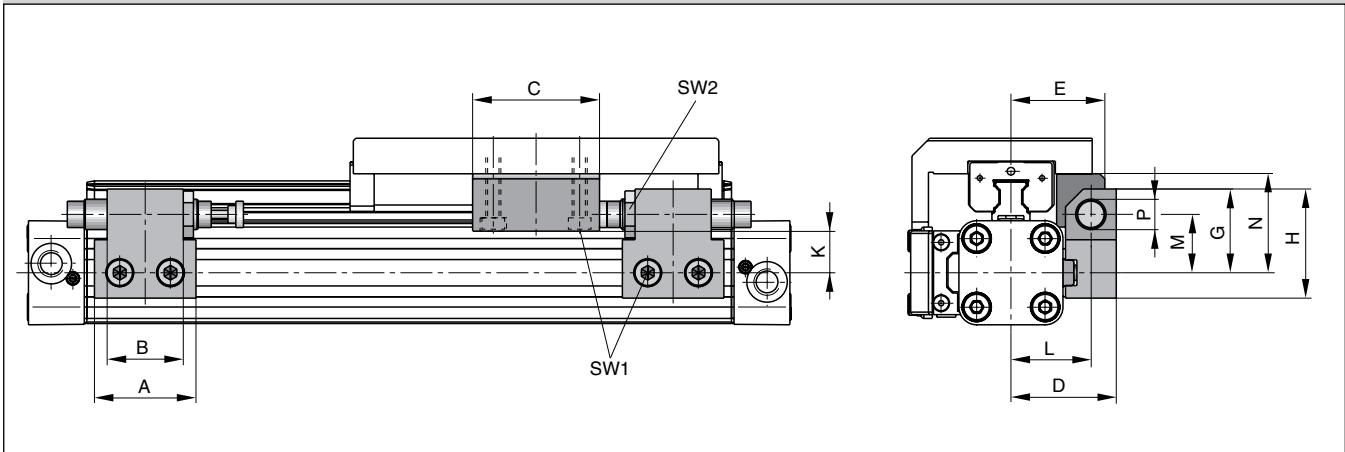

Dimension Table (mm) – Variable Stop Type VS16 to VS50

Series	Type	A	B	C	D	E	G	H	K	L	M	N	P	SW1	SW2
OSP-STL16	VS16	30	14	25	33	30	28	38	16.2	25.5	20.5	30	M10x1	4	12.5
OSP-STL25	VS25	40	30	50	41.5	37	33	43	18	31.5	23	39	M12x1	5	16
OSP-STL32	VS32	60	40	50	45.5	42	35	45	19	35.5	25	48	M14x1.5	5	17
OSP-STL40	VS40	84	52	60	64	59	48	63	25.6	50	34	58.6	M20x1.5	5	24
OSP-STL50	VS50	84	-	60	75	69	55	70	26.9	57	38	66.9	M25x1.5	5	30

Order Information – Variable Stop Type VS16 to VS50

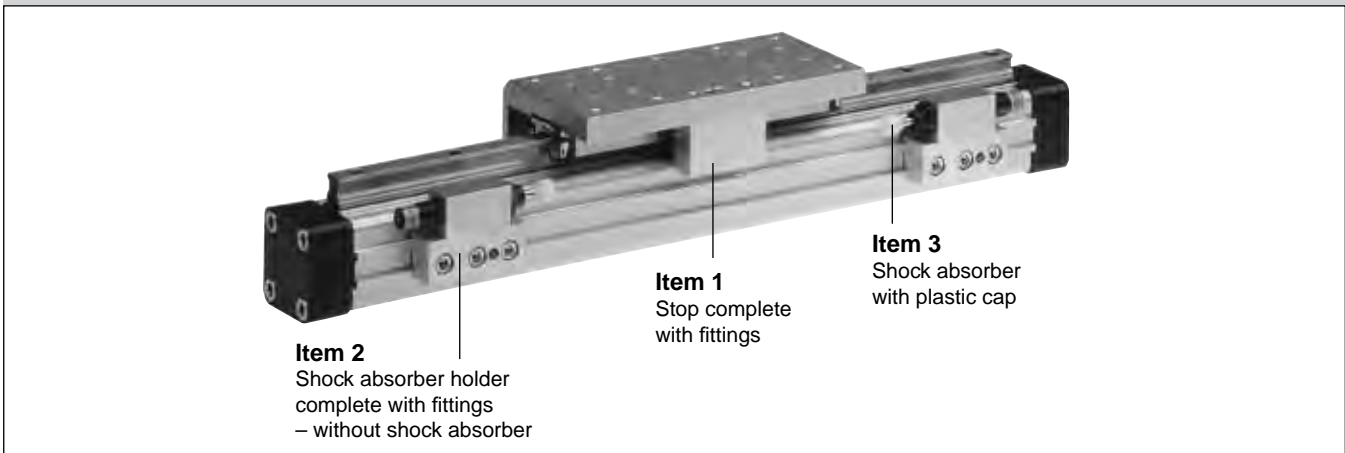

Order Instructions – Variable Stop Type VS16 to VS50

Item	Description	Size VS16		VS25		VS32		VS40		VS50	
		Type	Order No.	Type	Order No.	Type	Order No.	Type	Order No.	Type	Order No.
1	Stop, complete	-	21196	-	21197	-	21198	-	21199	-	21200
2	Shock absorber holder, complete	-	21201	-	21202	-	21203	-	21204	-	21205
3 *	Shock absorber, standard	SA10	7718	SA12	7706	SA14	7708	SA20	7710	SAI25	7712
	Shock absorber, version S	SA10S	7721	SA12S	7707	SA14S	7709	SA20S	7711	SAI25S	7835

* Shock absorber with plastic cap

Linear Drive Accessories

Ø 16 to 32 mm

End Cap Mounting Type: B

B

for Linear Drives with Recirculating Ball Bearing Guide

- Series OSP-P STL
- Series OSP-P KF

Material:

Galvanized steel
Anodized aluminum

The mountings are supplied in pairs.

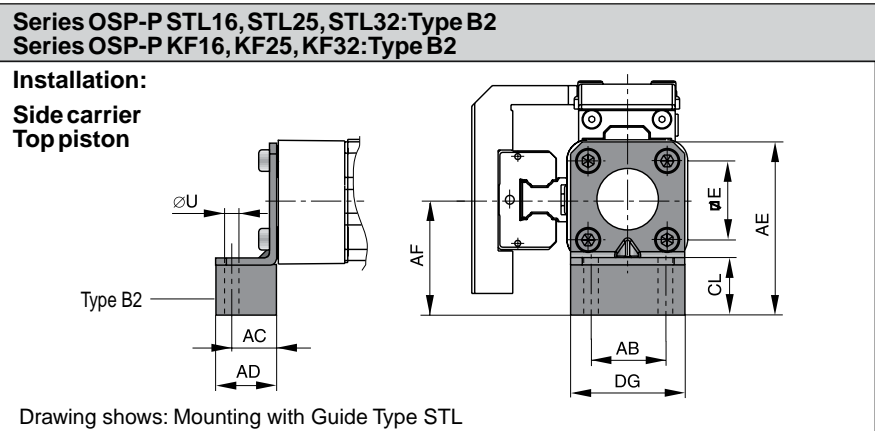
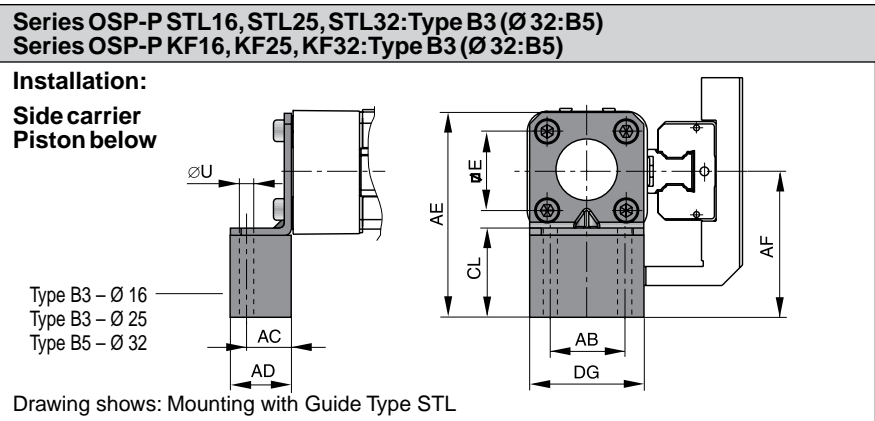
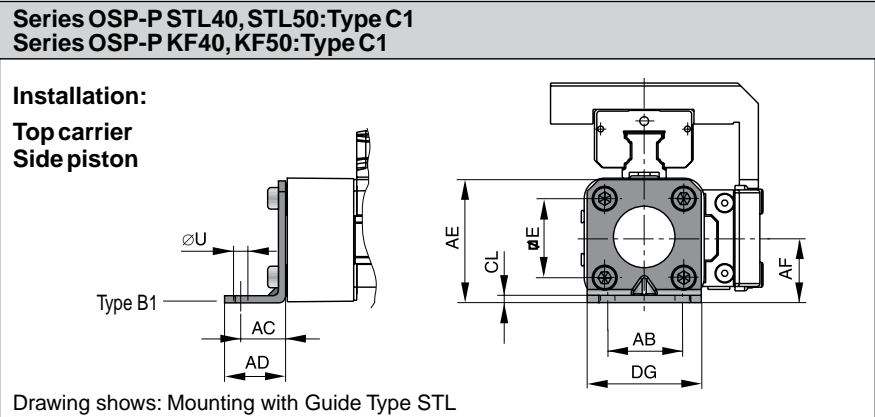

Dimension Table (mm) for End Cap Mounting Type: B1 to B5

Series Type	Mounting	E	ØU	AB	AC	AD	AE	AF	CL	DG	Order No. (pair)
OSP-P STL16	B1	18	3.6	18	10	14	28	15	2	26	21135
OSP-P KF16	B2	18	3.6	18	10	14	43	30	17	26	21136
	B3	18	3.6	18	10	14	55	42	29	26	21137
OSP-P STL25	B1	27	5.8	27	16	22	42	22	2.5	39	20311
OSP-P KF25	B2	27	5.8	27	16	22	57	37	17.5	39	21138
	B3	27	5.8	27	16	22	69	49	29.5	39	21139
OSP-P STL32	B1	36	6.6	36	18	26	55	30	3	50	20313
OSP-P KF32	B2	36	6.6	36	18	26	69	44	17	50	21140
	B5	36	6.6	36	18	26	90	65	9	50	21141

End Cap Mounting Type C

Series OSP-P STL40, STL50: Type C1
Series OSP-P KF40, KF50: Type C1

Installation:
Top carrier
Side piston

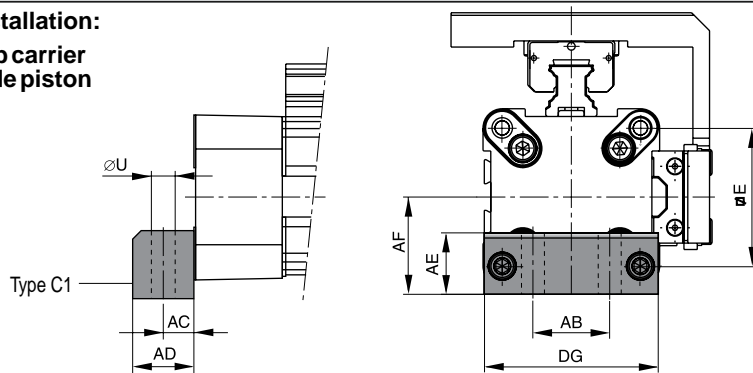

Drawing shows: Mounting with Guide Type STL

**Ø 40 to 50 mm
End Cap Mounting
Type: C**

for Linear Drives with
Recirculating Ball Bearing Guide

- Series OSP-P STL
- Series OSP-P KF

Material:

Anodized aluminum

The mountings are supplied in pairs.



Series OSP-P STL40, STL50: Type C4 (Ø 50: C3)
Series OSP-P KF40, KF50: Type C4 (Ø 50: C3)

Installation:
Side carrier
Piston below

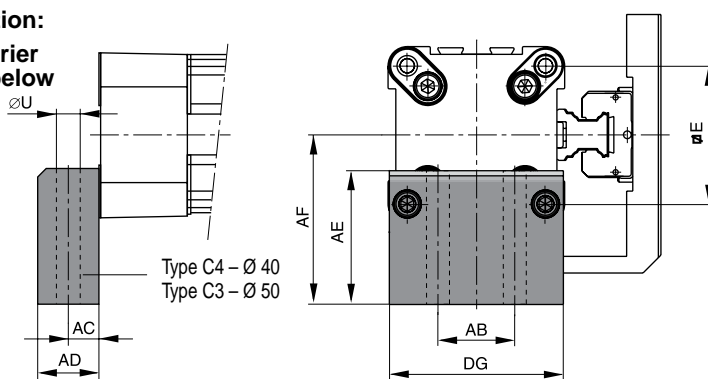

Drawing shows: Mounting with Guide Type STL

Series OSP-P STL40, STL50: Type C2
Series OSP-P KF40, KF50: Type C2

Installation:
Side carrier
Top piston

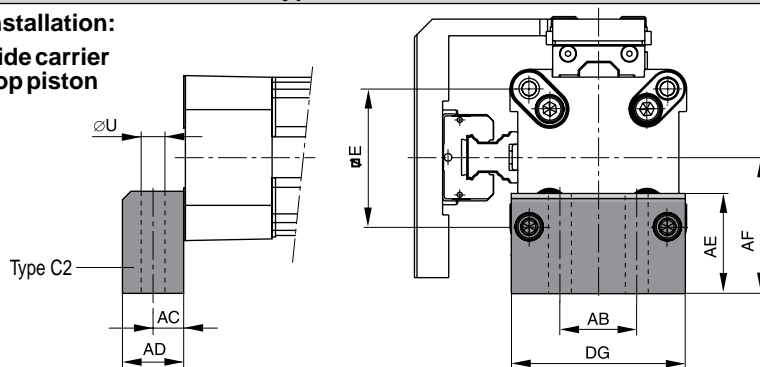

Drawing shows: Mounting with Guide Type STL

Dimension Table (mm) for End Cap Mounting Type: C1 to C4

Series Type	Mounting	E	ØU	AB	AC	AD	AE	AF	DG	Order No. (pair)
OSP-P STL40	C1	54	9	30	12.5	24	24	38	68	4010
OSP-P KF40	C2	54	9	30	12.5	24	37	51	68	20338
	C4	54	9	30	12.5	24	56	70	68	20340
OSP-P STL50	C1	70	9	40	12.5	24	30	48	86	5010
OSP-P KF50	C2	70	9	40	12.5	24	39	57	86	20349
	C3	70	9	40	12.5	24	54	72	86	20350



Mid-Section Support Type D1ST

Linear Drive Accessories

Ø 16 to 50 Mid-Section Support Type: D1ST

for Linear Drives with
 Recirculating Ball Bearing Guide

- Series OSP-P STL
- Series OSP-P KF

Note on Types D1ST

The mid-section support can also be mounted on the underside of the actuator, in which case its distance from the center of the actuator is different.

For design notes, see page
 B70 (Series OSP-P STL)
 B81 (Series OSP-P KF)



Mid-Section Support Type: E1ST to E5ST

for Linear Drives with
 Recirculating Ball Bearing Guide

- Series OSP-P STL
- Series OSP-P KF



Series OSP-P STL16 to STL50: Type D1ST
 Series OSP-P KF16 to KF50: Type D1ST

Mountings from below with 2 screws

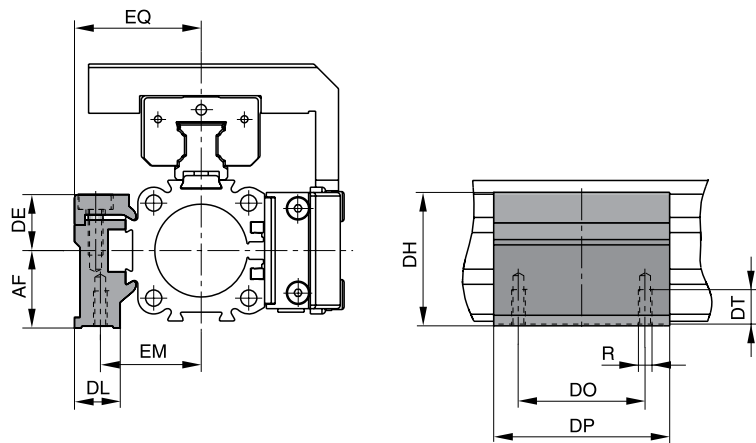

Drawing shows: Mounting with Guide Type STL

Dimension Table (mm) Mid-Section Support D1ST

Series OSP-P	Mounting Type	R	AF	DE	DH	DL	DO	DP	DT	EM	EQ	Order No.
STL/KF16	D1ST	M3	15	14.2	29.2	14.6	18	30	6.5	20	27	21125
STL/KF25	D1ST	M5	22	16	38	13	36	50	10	28.5	36	21126
STL/KF32	D1ST	M5	30	16	46	13	36	60	10	35.5	43	21127
STL/KF40	D1ST	M6	38	23	61	19	45	60	11	38	48	21128
STL/KF50	D1ST	M6	48	23	71	19	45	60	11	45	57	21129

Order example: Type D1ST16 Order No. 21125

Series OSP-P STL16 to STL50: Type E1ST
 Series OSP-P KF16 to KF50: Type E1ST

Installation:
 Top carrier
 Side position

Mounting from above / below
 using a cap screw

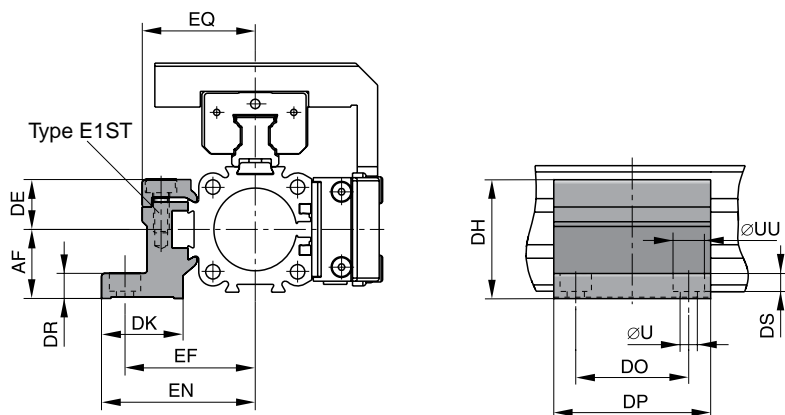

Drawing shows: Mounting with Guide Type STL

Mid-Section Support Type E1ST - E5ST

Mid-Section Support Type: E1ST to E5ST

for Linear Drives with Recirculating Ball Bearing Guide

- Series OSP-P STL
- Series OSP-P KF



B

Series OSP-P STL25 to STL50: Type E3ST, E4ST, E5ST
Series OSP-P STL25 to STL50: Type E3ST, E4ST, E5ST

Installation:
Side carrier
Piston below

Mounting from above / below using a cap screw

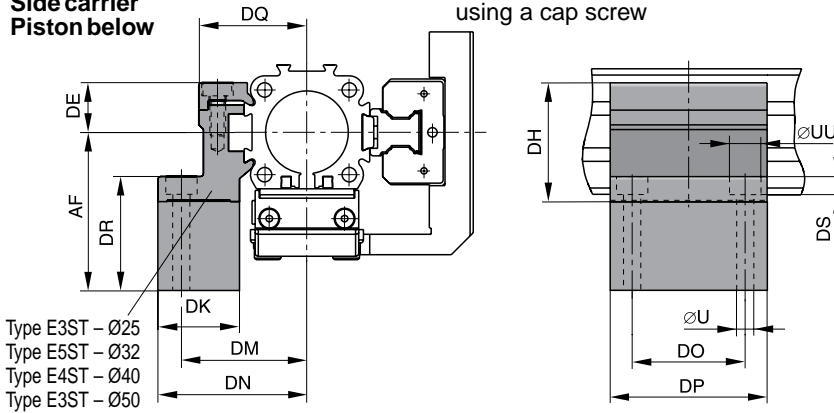

Type E3ST - Ø25
Type E5ST - Ø32
Type E4ST - Ø40
Type E3ST - Ø50

Drawing shows: Mounting with Guide Type STL

Series OSP-P STL16 to STL50: Type E2ST
Series OSP-P KF16 to KFL50: Type E2ST

Installation:
Side carrier
Top piston

Mounting from above / below using a cap screw

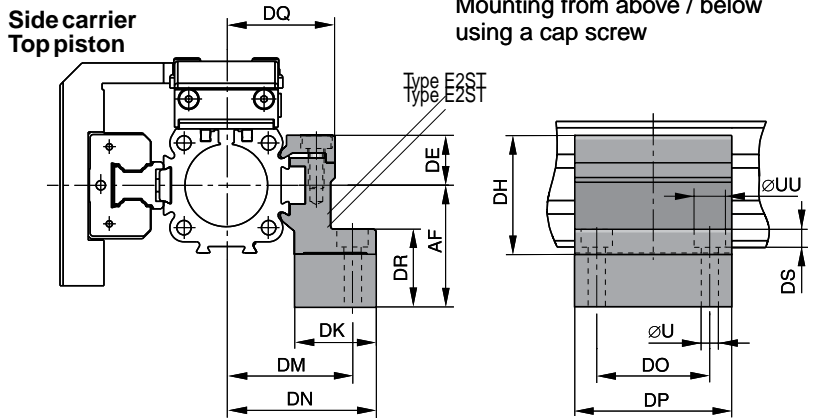

Type E2ST
Type E2ST

Drawing shows: Mounting with Guide Type STL

Dimension Table (mm) for Mid-Section Support E1ST to E5ST

Series OSP-P	Mounting Type	ØU	ØUU	AF	DE	DH	DK	DM	DN	DO	DP	DR	DQ	DS	EF	EN	EQ	Order No.
STL/KF16	E1ST	3.4	6	15	14.2	29.2	24	32	36.4	18	30	6	27	3.4	32	36.4	27	21130
STL/KF16	E2ST	3.4	6	30	14.2	29.2	24	32	36.4	18	30	21	27	3.4	32	36.4	27	21142
STL/KF25	E1ST	5.5	10	22	16	38	26	40	47.5	36	50	8	34.5	5.7	41.5	49	36	21131
STL/KF25	E2ST	5.5	10	37	16	38	26	40	47.5	36	50	23	34.5	5.7	41.5	49	36	21143
STL/KF25	E3ST	5.5	10	49	16	38	26	40	47.5	36	50	35	34.5	5.7	41.5	49	36	21148
STL/KF32	E1ST	5.5	10	30	16	46	27	46	54.5	36	60	10	40.5	5.7	48.5	57	43	21132
STL/KF32	E2ST	5.5	10	44	16	46	27	46	54.5	36	60	24	40.5	5.7	48.5	57	43	21144
STL/KF32	E5ST	5.5	10	65	16	46	27	46	54.5	36	60	45	40.5	5.7	48.5	57	43	21151
STL/KF40	E1ST	7	-	38	23	61	34	53	60	45	60	10	45	-	56	63	48	21133
STL/KF40	E2ST	7	-	51	23	61	34	53	60	45	60	23	45	-	56	63	48	21145
STL/KF40	E4ST	7	-	70	23	61	34	53	60	45	60	42	45	-	56	63	48	21150
STL/KF50	E1ST	7	-	48	23	71	34	59	67	45	60	10	52	-	64	72	57	21134
STL/KF50	E2ST	7	-	57	23	71	34	59	67	45	60	19	52	-	64	72	57	21146
STL/KF50	E3ST	7	-	72	23	71	34	59	67	45	60	34	52	-	64	72	57	21149

Order example: Type E1ST16

Order No. 21130



Ordering Instructions / Part Numbering System for OSP-P STARLINE Series



6	7	8	9	10	11	12-16	17	18	19	20	21	22	23	24	25
OSPP	32	0	0	0	0	02500	0	2	0	B	0	0	0	0	0
Bore 16 25 32 40 50		Seals 0 Standard 1 Viton S Special			Lubrication 0 Standard 1 Slow Speed 4 Food 5 Clean Room S Special		Stroke x x x x x		Piston Mountings 0 none		Dovetail Cover 0 Standard X Without Cover Rail S Special		Version 0 none 1 NO Reed-KL3045 Qty. 2 2 NC Reed-KL3048 Qty. 2 3 PNP KL3054+4041 Qty. 2 4 NPN KL3060+4041 Qty. 2 X 21240 SFI 0,1mm Y 21241 SFI 1mm Z 4650 SFA S Special Note: 2 switches will be supplied. For different quantity, please order as a separate line item.		
Piston Style 0 Standard 1 Tandem S Special		Corrosion Resist, Hardware 0 Standard 1 Stainless S Special		Cushioning / Stops 0 Standard 2 VS soft left 3 VS hard left 4 VS soft right 5 VS hard right 6 VS soft both sides 7 VS hard both sides S Special		End Cap Position 0 l+r 0° = in front (pos #2) 1 l+r 90° = underneath (pos #3) 2 l+r 180° = at the back (pos # 4) 3 l+r 270° = same face as outerband (pos #2,1) 4 l 90° = underneath; r 0° = in front (pos #3,2) 5 l 180° = at the back; r 0° = in front (pos #4,2) 6 l 270° = same face as outerband; r 0° = in front (pos #1,2) 7 l 0° = in front; r 90° = underneath (pos #2, 3) 8 l 180° = at the back; r 90° = underneath (pos #4,3) 9 l 270° = same face as outerband; r 90° = underneath (pos #1,3) A l 0° = in front; r 180° = at the back (pos #2,4) B l 90° = underneath; r 180° = at the back (pos #3,4) C l 270° = same face as outerband; r 180° = at the back (pos #1,4) D l 0° = in front; r 270° = same face as outerband (pos #2,1) E l 90° = underneath; r 270° = same face as outerband (pos #3,1) F l 180° = at the back; r 270° = same face as outerband (pos #4,1) S Special		End Cap Mounts 0 without 4 B1 (16,25,32) 5 B2 (16,25,32) 6 B3 (16,25) 8 B5 (32) 9 C1 (40,50) A C2 (40,50) B C3 (50) C C4 (40) Note: Comes in pairs		Guides / Brakes B STL Starline		add. Carriage 0 without B Guide Carriage Starline STL			
Air Connections / Porting 0 Standard (position #2) 1 end face (position #5) 2 single end porting 3 left stand (pos #2), right end face (pos#5) 4 right stand (pos #2), left end face (pos #5) 6 single end porting end face A 3/2 Way valve VOE 24V = (25,32,40,50) B 3/2 Way valve VOE 220V~/110V= (25,32,40,50) C 3/2 Way valve VOE 48V=(25,32,40,50) E 3/2 Way valve VOE 110V- (25,32,40,50) S Special Note: Single End Porting on 16mm bore, then end caps cannot be rotated.															

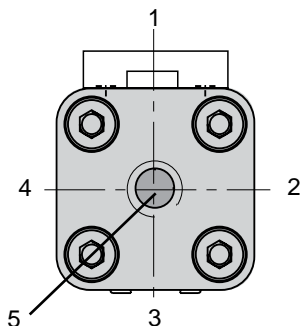

Note: Position #2 is the standard location.

Versions

for Pneumatic Linear Drive:
 Series OSP-P KF



Recirculating Ball Bearing Guide KF



Loads, Forces and Moments

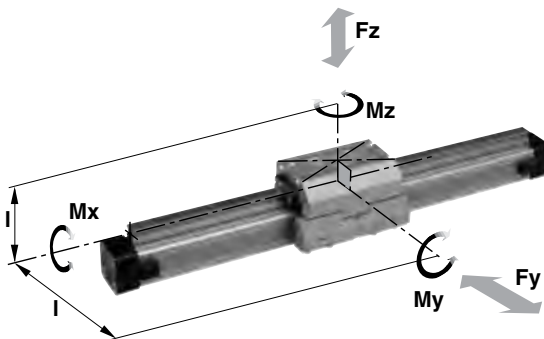

Series KF16 to KF50
 For Linear Drives
 Series OSP-P CLASSIC

Features:

- Anodized aluminum guide carriage, the mounting dimensions correspond to FESTO Type: DGPL-KF
- Polished and hardened steel guide rail
- For high loads in all directions
- High precision
- Integrated wiper system
- Integrated grease nipples
- Any length of stroke up to 3700 mm
- Maximum speed
 KF16, KF40: v = 3 m/s
 KF25, KF32, KF50: v = 5 m/s

Technical Data

The table shows the maximum permissible loads. If multiple moments and forces act upon the cylinder simultaneously, the following equation applies:

$$\frac{M_x}{M_{x_{max}}} + \frac{M_y}{M_{y_{max}}} + \frac{M_z}{M_{z_{max}}} + \frac{F_y}{F_{y_{max}}} + \frac{F_z}{F_{z_{max}}} \leq 1$$

The sum of the loads should not exceed >1

The table shows the maximum permissible values for light, shock-free operation, which must not be exceeded even under dynamic conditions.

*** Please note:**

the mass of the carriage has to be added to the total moving mass when using the cushioning diagram.

Series	for Linear Drive	Max. Moments (Nm)			Max. Load (N)		Mass of drive with guide (kg) with 0 mm stroke	increase per 100 mm stroke	Mass* guide carriage (kg)	Groove stone Thread Size
		Mx	My	Mz	Fy	Fz				
KF16	OSP-P16	12	25	25	1000	1000	0.558	0.21	0.228	–
KF25	OSP-P25	35	90	90	3100	3100	1.522	0.369	0.607	M5
KF32	OSP-P32	44	133	133	3100	3100	2.673	0.526	0.896	M5
KF40	OSP-P40	119	346	346	4000	7100	4.167	0.701	1.531	M6
KF50	OSP-P50	170	480	480	4000	7500	7.328	0.936	2.760	M8

Dimensions Series OSP-P KF16 to KF50

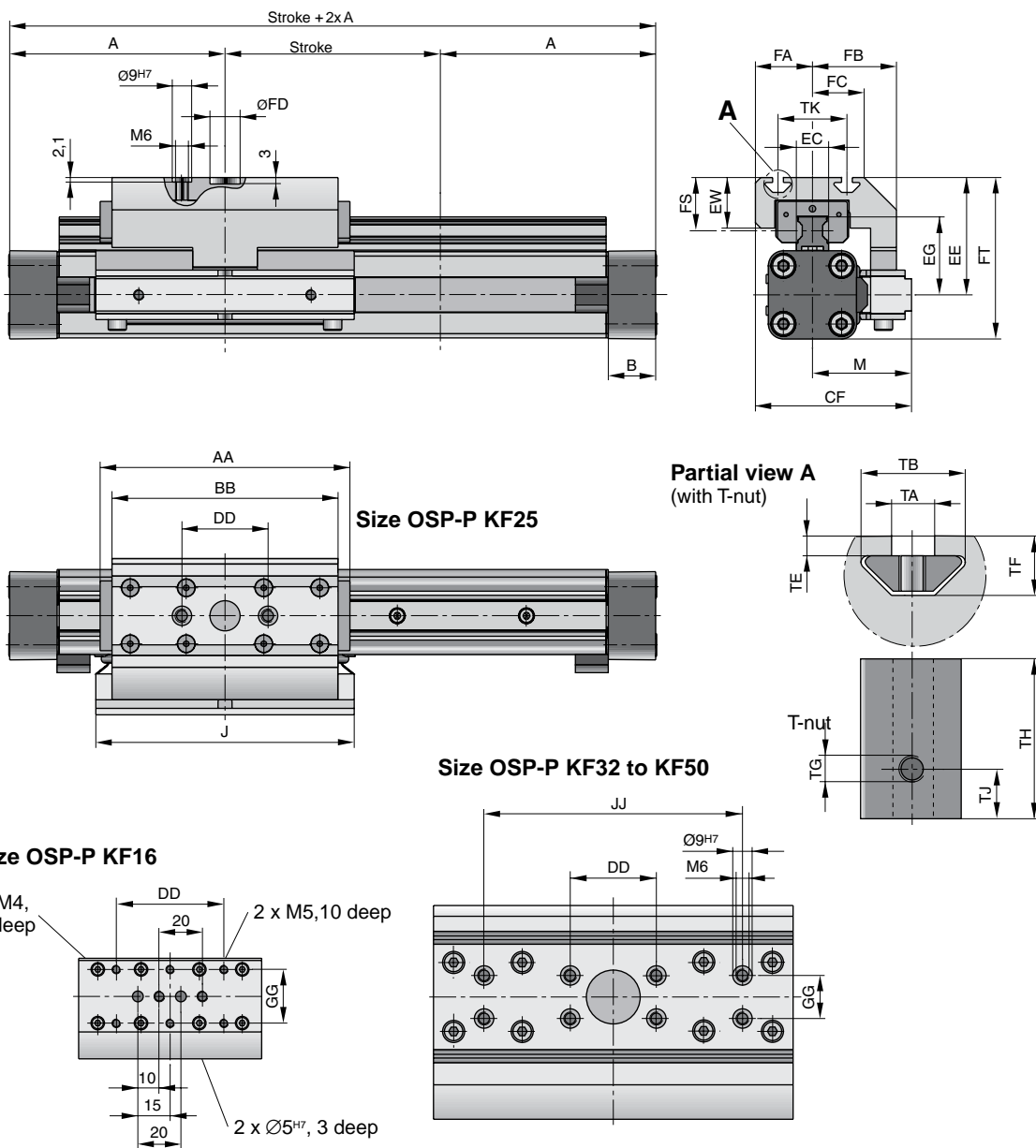

Dimension Table (mm) Series OSP-P KF16, KF25, KF32, KF40, KF50

Series	A	B	J	AA	BB	CF	DD	EC	EE	EG	EW	JJ	GG	M
KF16	65	14	76	93	85	48	50	15	41	24.6	10	—	25	30
KF25	100	22	120	120.2	105	72.5	40	15	54.5	36.2	23.5	—	—	46
KF32	125	25.5	160	146.2	131	93.8	40	15	60.5	42.2	23.5	—	20	59.8
KF40	150	28	150	188.5	167	103.3	40	20	69.5	51.6	26.5	120	20	60.8
KF50	175	33	180	220.2	202	121	40	23	90.5	62.3	32.5	120	40	69

Series	FA	FB	FC	FD	FT	FS	TA	TB	TE	TF	TG	TH	TJ	TK
KF16	17.7	29	16.5	—	56	19	—	—	—	—	—	—	—	—
KF25	26.5	39	24	14 ^{G7}	75	24.7	5	12.1	2.3	6.9	M5	11.5	4	32
KF32	34	53.8	34	25 ^{G7}	86.5	24.7	5	12.1	1.8	6.4	M5	11.5	4	47
KF40	42.5	56.8	41	25 ^{G7}	104	26	6	12.8	1.8	8.4	M6	17	5.5	55
KF50	52	65	50	25 ^{G7}	134	38	8	21.1	4.5	12.5	M8	23	7.5	72

B

Permissible Unsupported Length OSP-P KF16 to KF50

Loading 1 – Top carrier

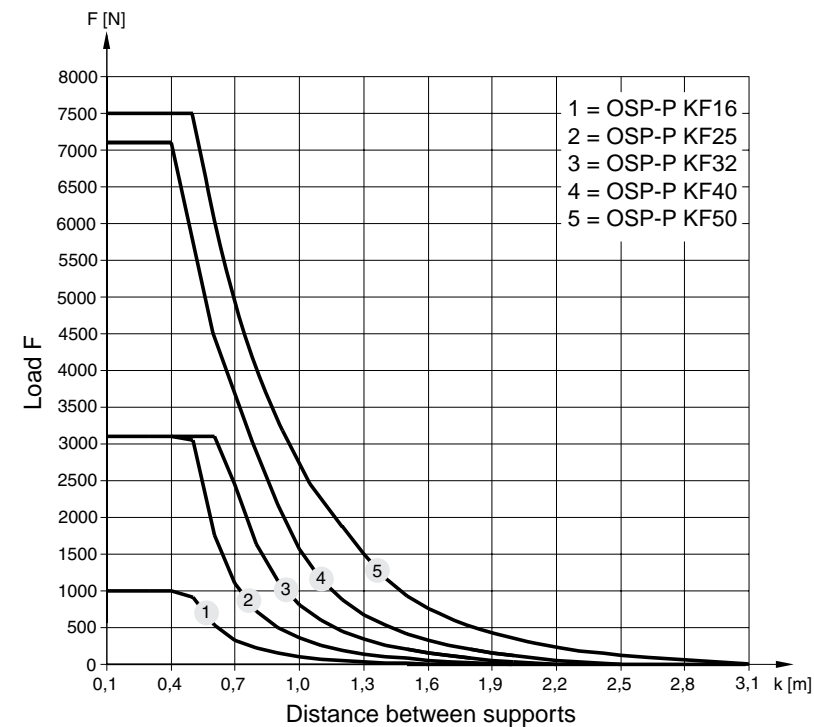

Permissible Unsupported Length OSP-P KF16 to KF50

Loading 2 – Side carrier

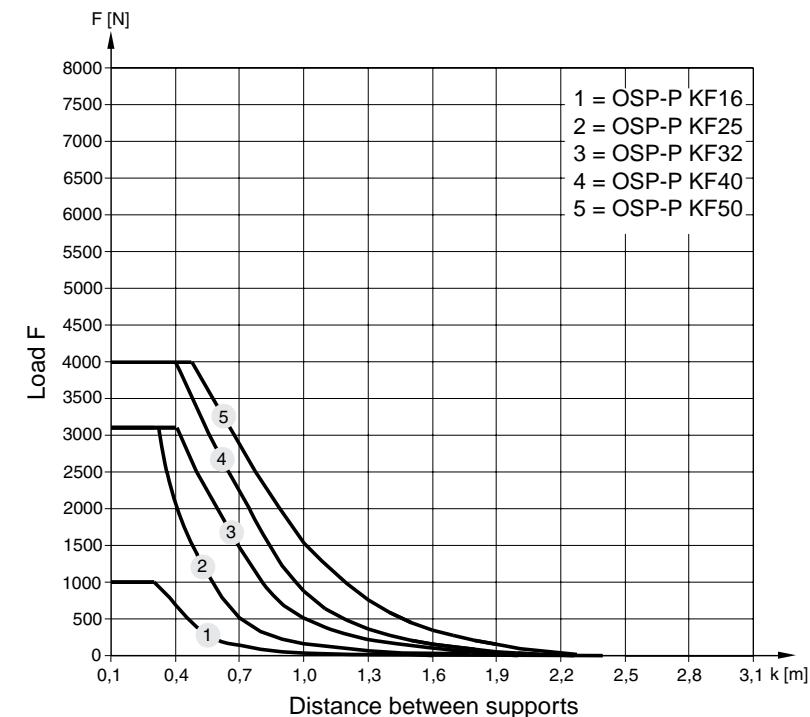

Mid-Section Support

(For versions, see pages B87-B88)
 Mid-section supports are required from a certain stroke length to prevent excessive deflection and vibration of the linear drive. The diagrams show the maximum permissible unsupported length in relation to loading. A distinction must be drawn between loading 1 and loading 2.
 Deflection of 0.5 mm max. between supports is permissible.

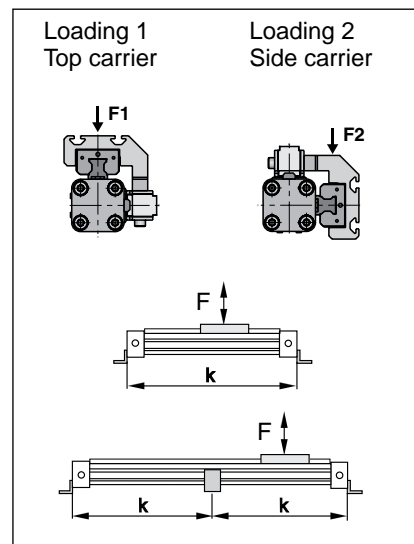

Note:
 For speeds $v > 0.5$ m/s the distance between supports should not exceed 1 m.

Variable Stop

The variable stop Type VS provides simple stroke limitation.

It can be retrofitted and positioned anywhere along the stroke length. For every cylinder diameter two types of shock absorber are available – see “Shock Absorber Selection” below.

Mid-section supports and magnetic switches can still be fitted on the same side as the variable stop.

Depending on the application, two variable stops can be fitted if required.

Variable Stop Type VS16 to VS50

Arrangement with two variable stops

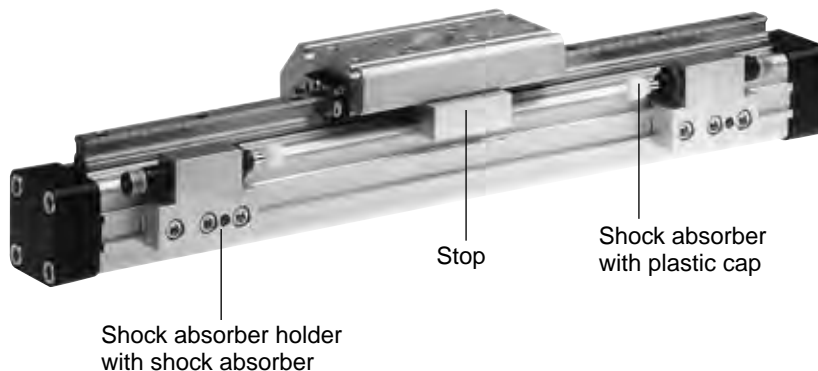

Shock Absorber Selection

The shock absorber is selected in dependence on the mass and speed.

The mass of the carrier itself must be taken into account.

Shock Absorber Selection in Dependence on Mass and Speed for Series OSP-KF16

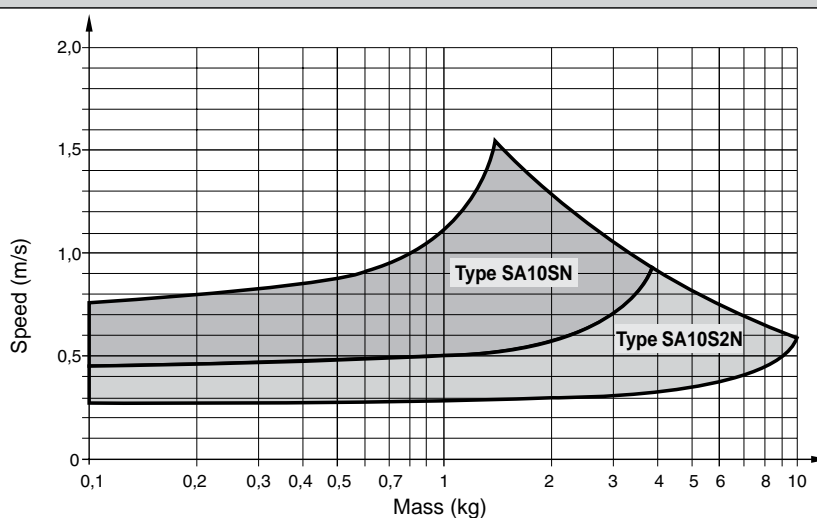

The values relate to an effective driving force of 78 N (6 bar)

Shock Absorber Selection in Dependence on Mass and Speed for Series OSP-KF25

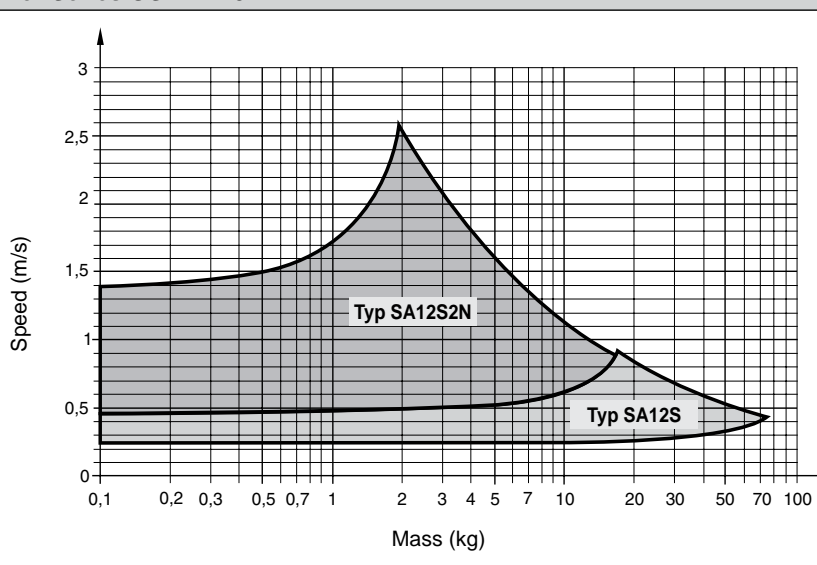

The values relate to an effective driving force of 250 N (6 bar)

B



Shock Absorber Selection in Dependence on Mass and Speed for Series OSP-KF32

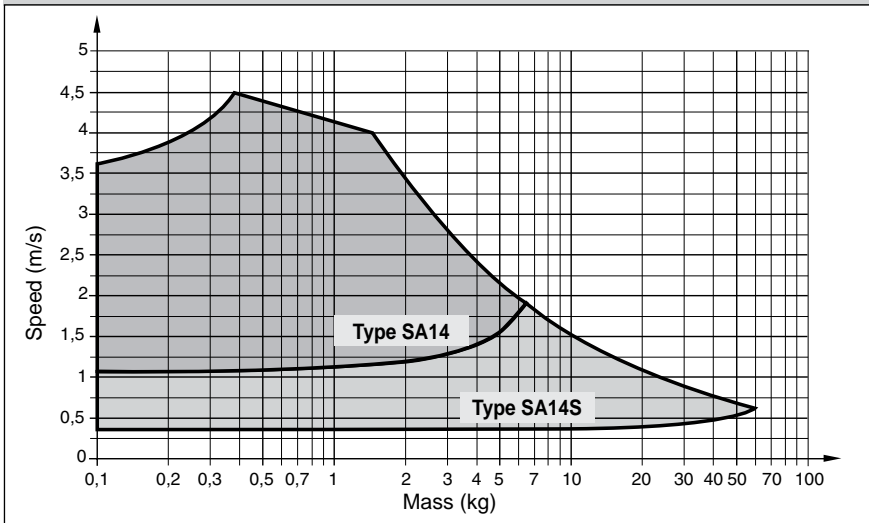

The values relate to an effective driving force of 420 N (6 bar)

Shock Absorber Selection in Dependence on Mass and Speed for Series OSP-KF40

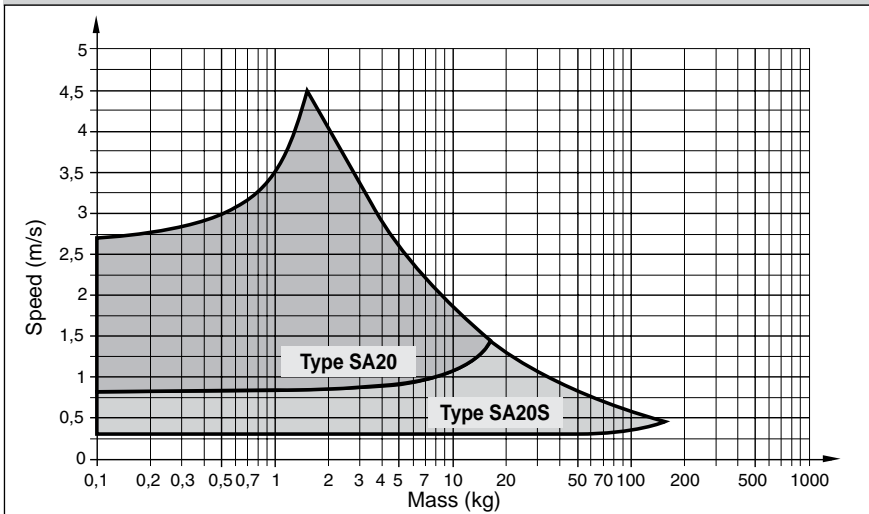

The values relate to an effective driving force of 640 N (6 bar)

Shock Absorber Selection in Dependence on Mass and Speed for Series OSP-KF50

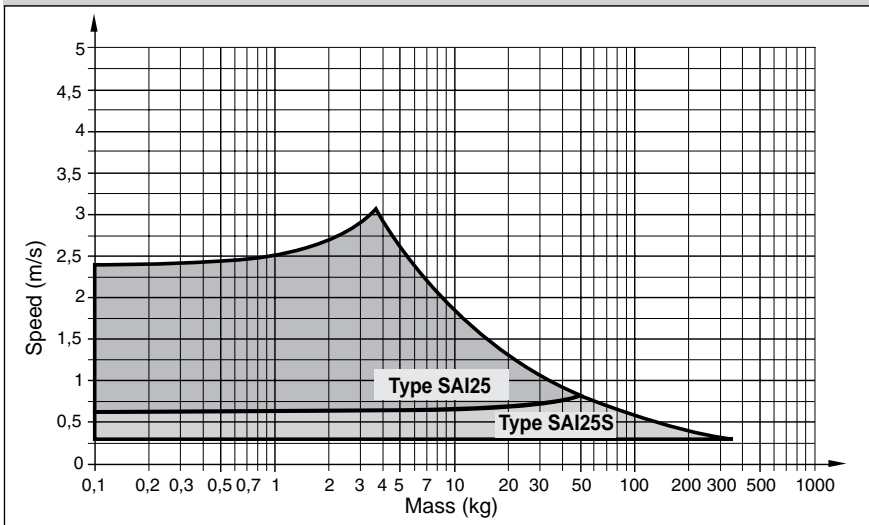

The values relate to an effective driving force of 1000 N (6 bar)

Dimensions – Variable Stop Type VS16 to VS50

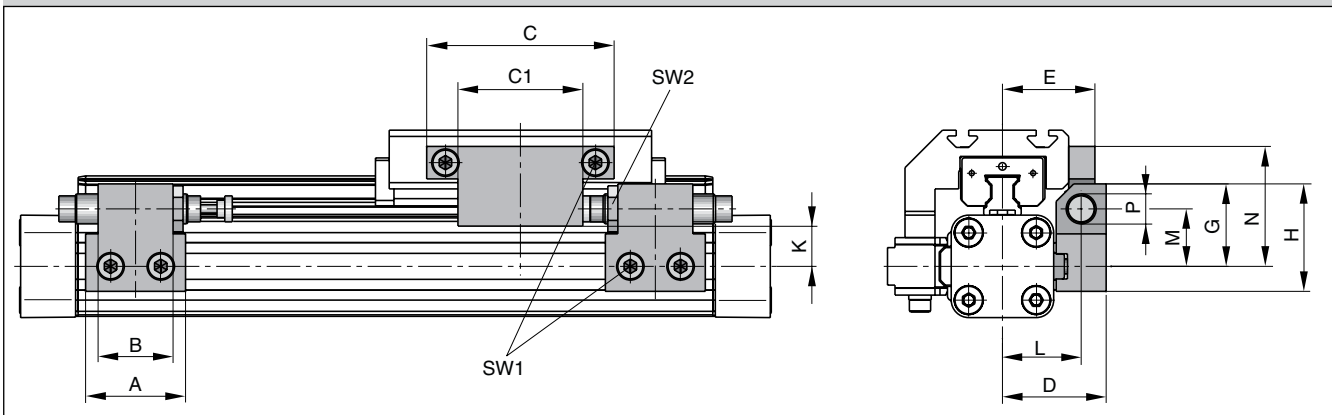

Dimension Table (mm) – Variable Stop Type VS16 to VS50

Series	Type	A	B	C	C1	D	E	G	H	K	L	M	N	P	SW1	SW2
OSP-KF16	VS16	30	14	50	25	33	29.7	28	38	16.2	25.5	20.5	40.5	M10 x 1	4	12.5
OSP-KF25	VS25	40	30	75	50	41.5	37	33	43	18	31.5	23	48	M12 x 1	5	16
OSP-KF32	VS32	60	40	50	-	45.5	41.5	35	45	19	35.5	25	37	M14 x 1.5	5	17
OSP-KF40	VS40	84	52	60	-	64	59	48	63	25.5	50	34	43	M20 x 1.5	5	24
OSP-KF50	VS50	84	-	60	-	75	69	55	70	26.9	57	38	58	M25 x 1.5	5	30

Order Information – Variable Stop Type VS16 to VS50

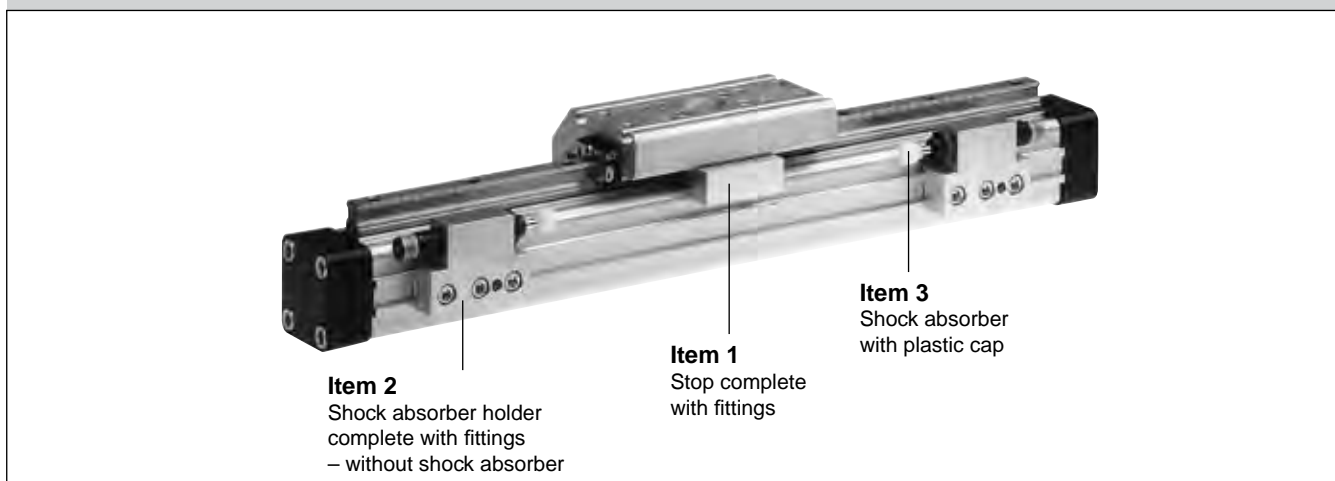

Order Instructions – Variable Stop Type VS16 to VS50

Item	Description	Size VS16		VS25		VS32		VS40		VS50	
		Type	Order No.	Type	Order No.	Type	Order No.	Type	Order No.	Type	Order No.
1	Stop, complete	-	21186	-	21187	-	21188	-	21189	-	21190
2	Shock absorber holder, complete	-	21201	-	21202	-	21203	-	21204	-	21205
3 *	Shock absorber, standard	SA10SN	7718	SA12S2N	7723	SA14	7708	SA20	7710	SAI25	7712
	Shock absorber, version S	SA10S2N	7721	SA12S	7707	SA14S	7709	SA20S	7711	SAI25S	7713

* Shock absorber with plastic cap

B

End Cap Mounting Type B

Series OSP-P STL40, STL50: Type C1
Series OSP-P KF40, KF50: Type C1

Installation:
Top carrier
Side piston

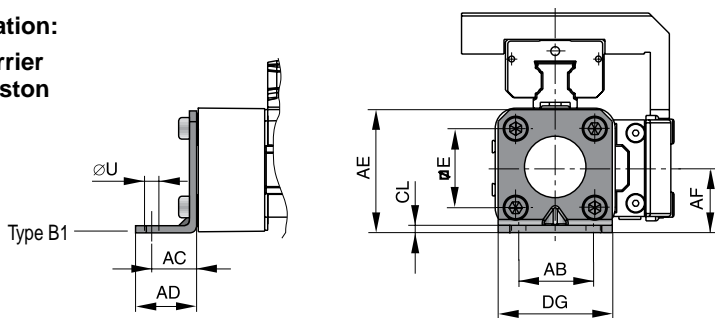

Drawing shows: Mounting with Guide Type STL

Series OSP-P STL16, STL25, STL32: Type B3 (Ø 32: B5)
Series OSP-P KF16, KF25, KF32: Type B3 (Ø 32: B5)

Installation:
Side carrier
Piston below

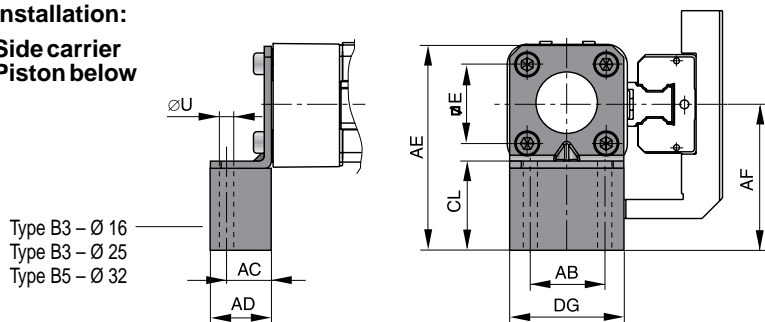

Drawing shows: Mounting with Guide Type STL

Series OSP-P STL16, STL25, STL32: Type B2
Series OSP-P KF16, KF25, KF32: Type B2

Installation:
Side carrier
Top piston

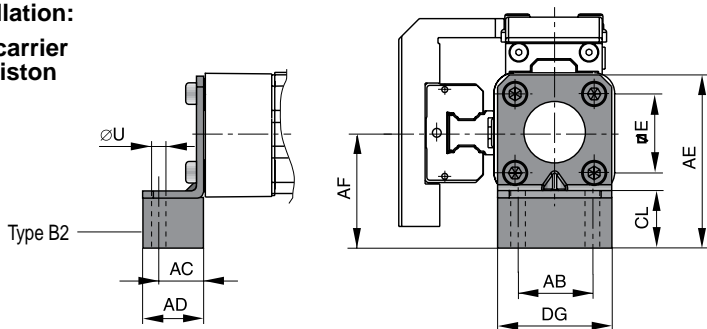

Drawing shows: Mounting with Guide Type STL

Dimension Table (mm) for End Cap Mounting Type: B1 to B5

Series Type	Mounting	E	ØU	AB	AC	AD	AE	AF	CL	DG	Order No. (pair)
OSP-P STL16	B1	18	3.6	18	10	14	28	15	2	26	21135
OSP-P KF16	B2	18	3.6	18	10	14	43	30	17	26	21136
	B3	18	3.6	18	10	14	55	42	29	26	21137
OSP-P STL25	B1	27	5.8	27	16	22	42	22	2.5	39	20311
OSP-P KF25	B2	27	5.8	27	16	22	57	37	17.5	39	21138
	B3	27	5.8	27	16	22	69	49	29.5	39	21139
OSP-P STL32	B1	36	6.6	36	18	26	55	30	3	50	20313
OSP-P KF32	B2	36	6.6	36	18	26	69	44	17	50	21140
	B5	36	6.6	36	18	26	90	65	9	50	21141

Linear Drive Accessories

Ø 16 to 32 mm

End Cap Mounting Type: B

for Linear Drives with Recirculating Ball Bearing Guide

- Series OSP-P STL
- Series OSP-P KF

Material:
Galvanized steel
Anodized aluminum

The mountings are supplied in pairs.



Ø 40 to 50 mm
End Cap Mounting
Type: C

for Linear Drives with
Recirculating Ball Bearing Guide

- Series OSP-P STL
- Series OSP-P KF

Material:
Anodized aluminum

The mountings are supplied in pairs.



Series OSP-P STL40, STL50: Type C1
Series OSP-P KF40, KF50: Type C1

Installation:
Top carrier
Side piston

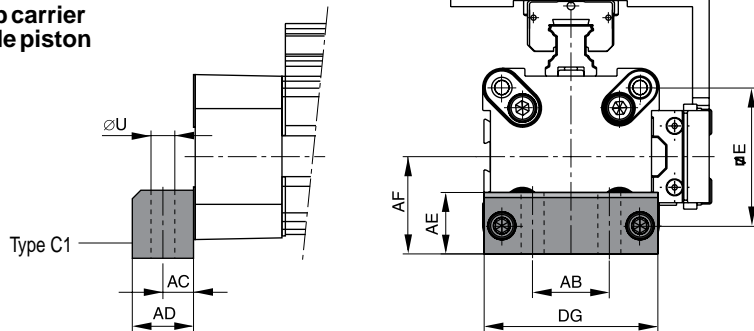

Drawing shows: Mounting with Guide Type STL

Series OSP-P STL40, STL50: Type C4 (Ø 50: C3)
Series OSP-P KF40, KF50: Type C4 (Ø 50: C3)

Installation:
Side carrier
Piston below

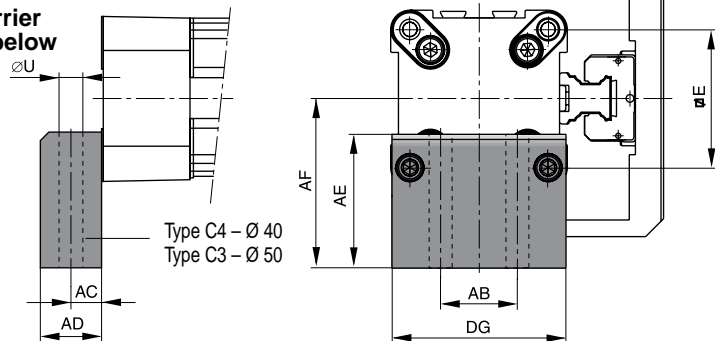

Drawing shows: Mounting with Guide Type STL

Series OSP-P STL40, STL50: Type C2
Series OSP-P KF40, KF50: Type C2

Installation:
Side carrier
Top piston

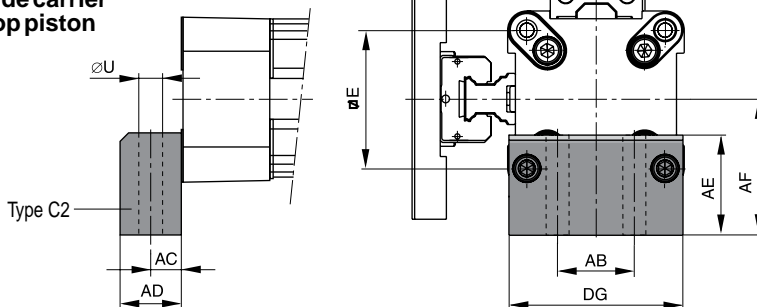

Drawing shows: Mounting with Guide Type STL

Dimension Table (mm) for End Cap Mounting Type: C1 to C4

Series Type	Mounting	E	ØU	AB	AC	AD	AE	AF	DG	Order No. (pair)
OSP-P STL40 OSP-P KF40	C1	54	9	30	12.5	24	24	38	68	4010
	C2	54	9	30	12.5	24	37	51	68	20338
	C4	54	9	30	12.5	24	56	70	68	20340
OSP-P STL50 OSP-P KF50	C1	70	9	40	12.5	24	30	48	86	5010
	C2	70	9	40	12.5	24	39	57	86	20349
	C3	70	9	40	12.5	24	54	72	86	20350

Mid-Section Support Type D1ST

Series OSP-P STL16 to STL50: Type D1ST
Series OSP-P KF16 to KF50: Type D1ST

Mountings from below with 2 screws

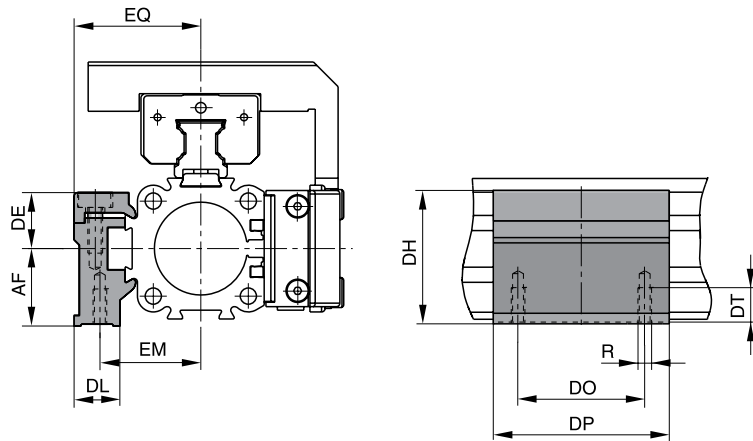

Drawing shows: Mounting with Guide Type STL

Dimension Table (mm) Mid-Section Support D1ST

Series OSP-P	Mounting Type	R	AF	DE	DH	DL	DO	DP	DT	EM	EQ	Order No.
STL/KF16	D1ST	M3	15	14.2	29.2	14.6	18	30	6.5	20	27	21125
STL/KF25	D1ST	M5	22	16	38	13	36	50	10	28.5	36	21126
STL/KF32	D1ST	M5	30	16	46	13	36	60	10	35.5	43	21127
STL/KF40	D1ST	M6	38	23	61	19	45	60	11	38	48	21128
STL/KF50	D1ST	M6	48	23	71	19	45	60	11	45	57	21129

Order example: Type D1ST16 Order No. 21125

Linear Drive Accessories

Ø 16 to 50

Mid-Section Support Type: D1ST

for Linear Drives with Recirculating Ball Bearing Guide

- Series OSP-P STL
- Series OSP-P KF

Note on Types D1ST

The mid-section support can also be mounted on the underside of the actuator, in which case its distance from the center of the actuator is different.

For design notes, see page B70 (Series OSP-P STL)
B81 (Series OSP-P KF)



Series OSP-P STL16 to STL50: Type E1ST
Series OSP-P KF16 to KF50: Type E1ST

Installation:
Top carrier
Side position

Mounting from above / below using a cap screw

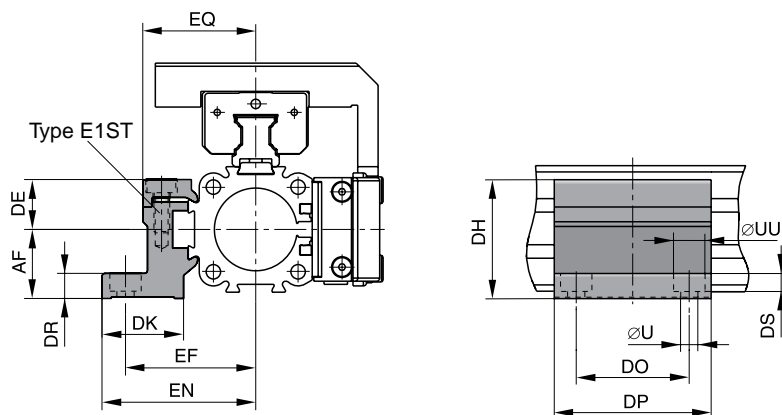

Drawing shows: Mounting with Guide Type STL

Mid-Section Support Type: E1ST to E5ST

for Linear Drives with Recirculating Ball Bearing Guide

- Series OSP-P STL
- Series OSP-P KF



Mid-Section Support Type E1ST - E5ST

**Mid-Section Support
 Type: E1ST to E5ST**

for Linear Drives with
 Recirculating Ball Bearing Guide

- Series OSP-P STL
- Series OSP-P KF

B



Series OSP-P STL25 to STL50: Type E3ST, E4ST, E5ST
 Series OSP-P STL25 to STL50: Type E3ST, E4ST, E5ST

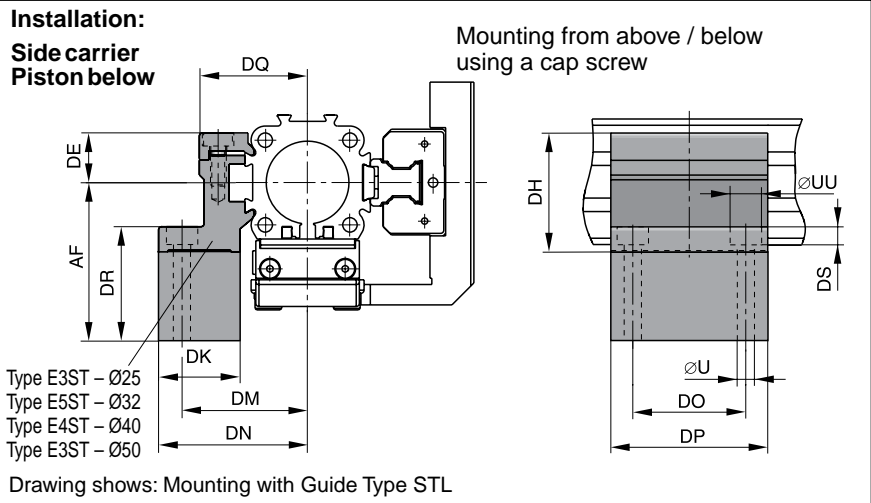

Series OSP-P STL16 to STL50: Type E2ST
 Series OSP-P KF16 to KFL50: Type E2ST

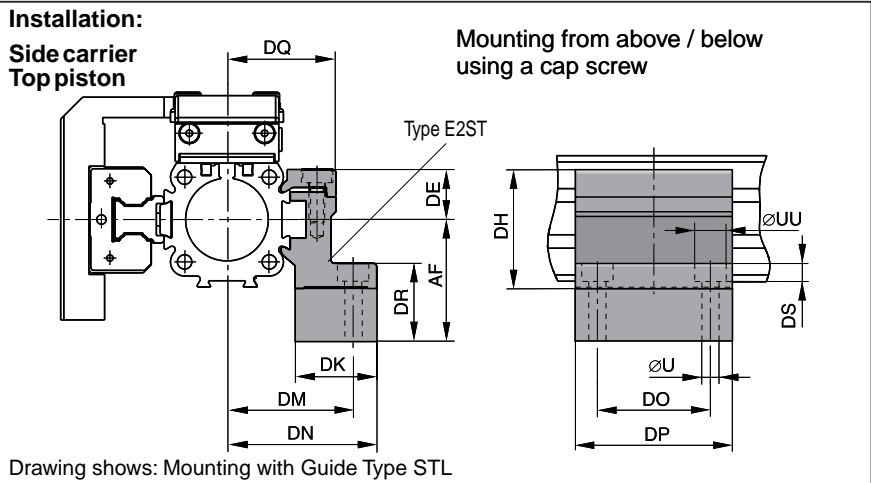

Dimension Table (mm) for Mid-Section Support E1ST to E5ST

Series OSP-P	Mounting Type	ØU	ØUU	AF	DE	DH	DK	DM	DN	DO	DP	DR	DQ	DS	EF	EN	EQ	Order No.
STL/KF16	E1ST	3.4	6	15	14.2	29.2	24	32	36.4	18	30	6	27	3.4	32	36.4	27	21130
STL/KF16	E2ST	3.4	6	30	14.2	29.2	24	32	36.4	18	30	21	27	3.4	32	36.4	27	21142
STL/KF25	E1ST	5.5	10	22	16	38	26	40	47.5	36	50	8	34.5	5.7	41.5	49	36	21131
STL/KF25	E2ST	5.5	10	37	16	38	26	40	47.5	36	50	23	34.5	5.7	41.5	49	36	21143
STL/KF25	E3ST	5.5	10	49	16	38	26	40	47.5	36	50	35	34.5	5.7	41.5	49	36	21148
STL/KF32	E1ST	5.5	10	30	16	46	27	46	54.5	36	60	10	40.5	5.7	48.5	57	43	21132
STL/KF32	E2ST	5.5	10	44	16	46	27	46	54.5	36	60	24	40.5	5.7	48.5	57	43	21144
STL/KF32	E5ST	5.5	10	65	16	46	27	46	54.5	36	60	45	40.5	5.7	48.5	57	43	21151
STL/KF40	E1ST	7	-	38	23	61	34	53	60	45	60	10	45	-	56	63	48	21133
STL/KF40	E2ST	7	-	51	23	61	34	53	60	45	60	23	45	-	56	63	48	21145
STL/KF40	E4ST	7	-	70	23	61	34	53	60	45	60	42	45	-	56	63	48	21150
STL/KF50	E1ST	7	-	48	23	71	34	59	67	45	60	10	52	-	64	72	57	21134
STL/KF50	E2ST	7	-	57	23	71	34	59	67	45	60	19	52	-	64	72	57	21146
STL/KF50	E3ST	7	-	72	23	71	34	59	67	45	60	34	52	-	64	72	57	21149

Order example: Type E1ST16

Order No. 21130



Series OSP-P KF25 to KF50: Type HP (Correspond to FESTO dimensions)

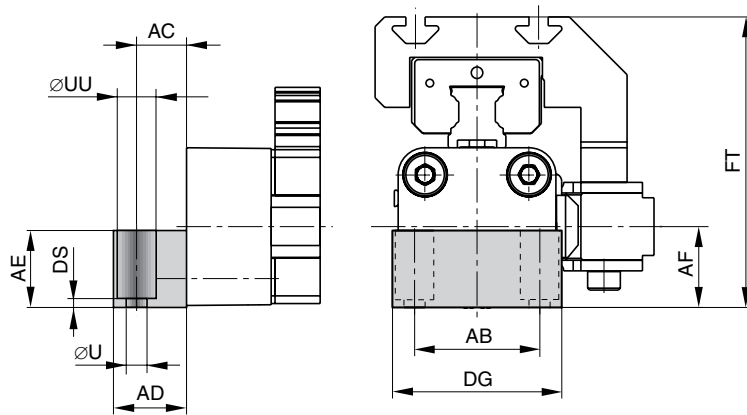

Note:
 Correspond to FESTO DGPL-KF, when the End Cap Mountings HP are mounted on the opposite side to the carriage (see drawing)

Linear Drive Accessories

Ø 25-50 mm
End Cap Mounting
 correspond to
FESTO dimensions
HP25 – 50

for Linear Drives with
 Recirculating Ball Bearing Guide

- Series OSP-P KF

On the end-face of each end cap there are four threaded holes for mounting the actuator.

Material:
 Series OSP-P KF25 – 50:
 Anodized aluminum.

The mountings are supplied in pairs.



Dimension Table (mm)

Series	∅U	AB	AC	AD	AE	AF	DG	DS	FT	∅UU	Order No.
HP25	5.5	32.5	13	19	20	21	44	2	75.5	10	21107
HP32	6.6	38	17	24	24	27	52	3	87.5	11	21108
HP40	6.6	45	17.5	24	24	35	68	2	104.5	11	21109
HP50	9	65	25	35	35	48	86	6	138.5	15	21110

Linear Drive Accessories

Ø 25-50 mm
Mid-Section Support
 correspond to
FESTO dimensions
MUP25 – 50

for Linear Drives with
 Recirculating Ball Bearing Guide

- Series OSP-P KF

Series OSP-P KF25: Type MUP
 (Mounting over through holes)

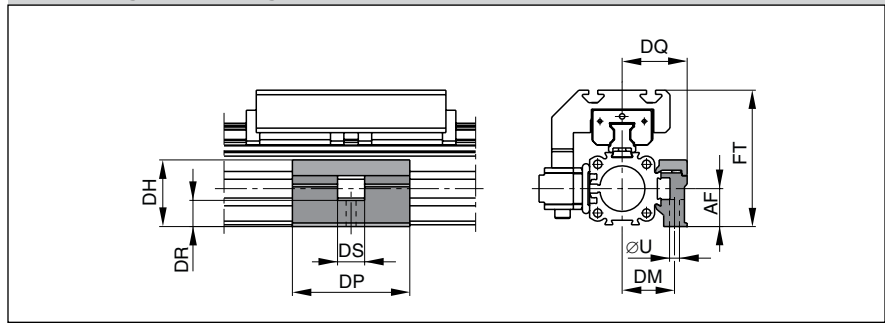

Series OSP-P KF32 to KF40: Type MUP
 (Mounting over through holes)

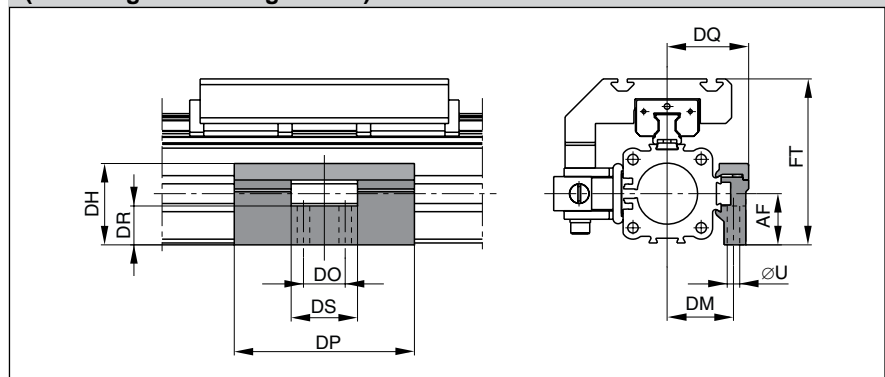

Series OSP-P KF50: Type MUP
 (Mounting over through holes)

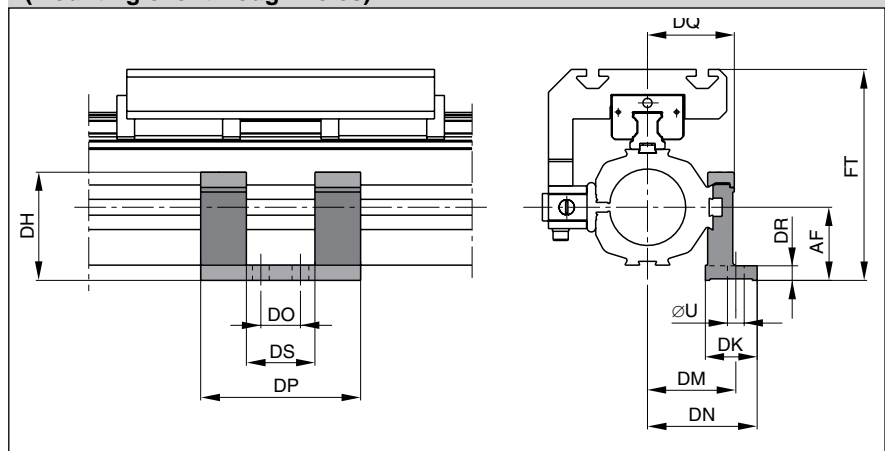

Note:
 Correspond to FESTO DGPL-KF,
 when the Mid-Section Support MUP
 are mounted on the 90° side to the
 carriage (see drawings).

Dimension Table (mm)

Series	ØU	AF	DH	DK	DM	DN	DO	DP	DQ	DR	DS	FT	Order No.
MUP25	5.5	21	36.9	–	29	–	–	65	36	14.5	15	75.5	21119
MUP32	6.6	27	42.9	–	35	–	22	95	43	20.5	35	87.5	21120
MUP40	6.6	35	58	–	40	–	22	95	48	28.5	35	104.5	21121
MUP50	11	48	71	34	58	72	26	105	57	10	45	138.5	21122

Ordering Instructions / Part Numbering System for OSP-P KF Series

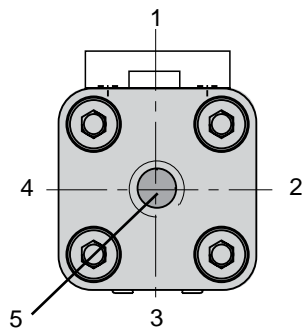
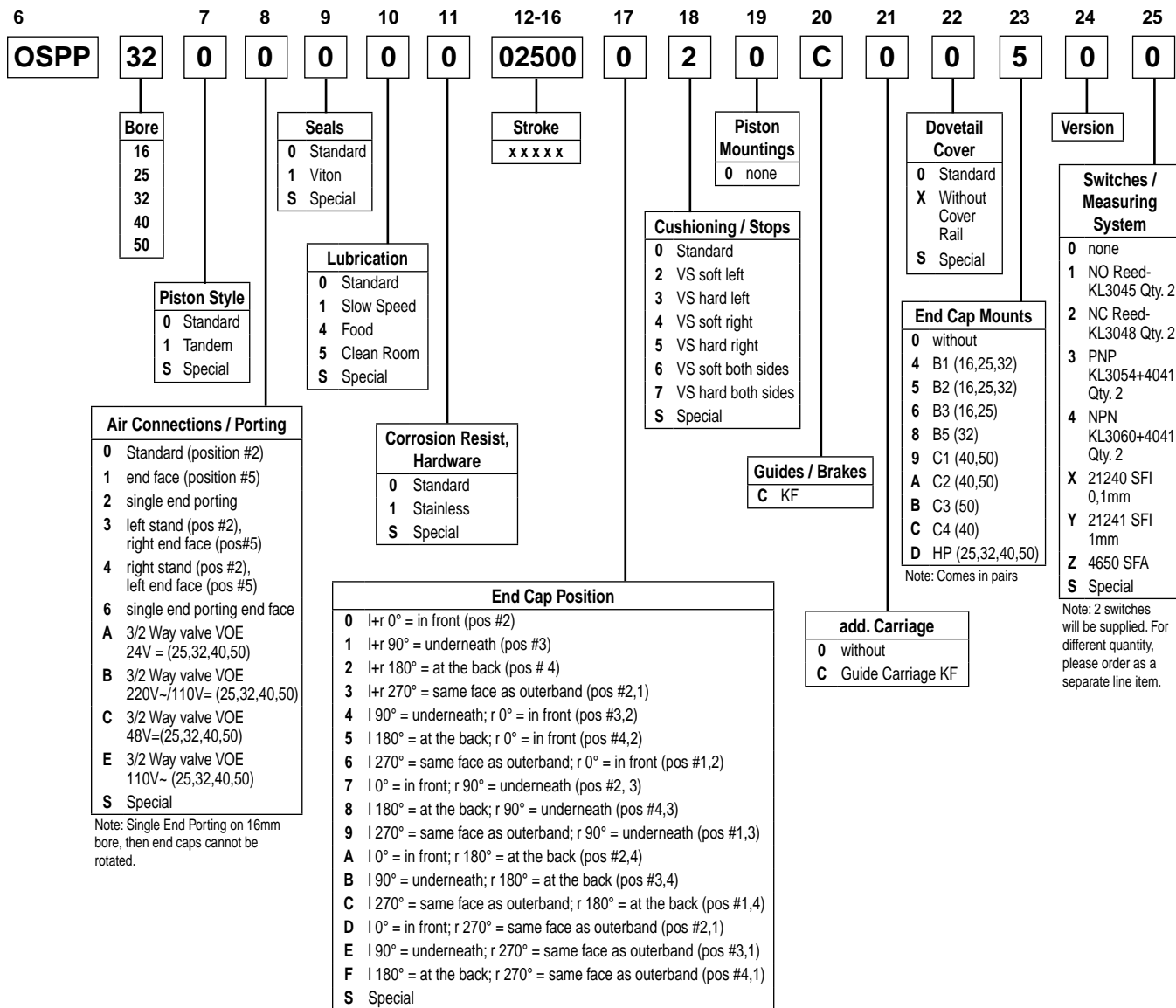

Note: Position #2 is the standard location.

Heavy Duty- Guide HD



B

**Series HD 25 to 50
 for Linear Drive Series OSP-P**

Version with Pneumatic Linear Drive Series OSP-P

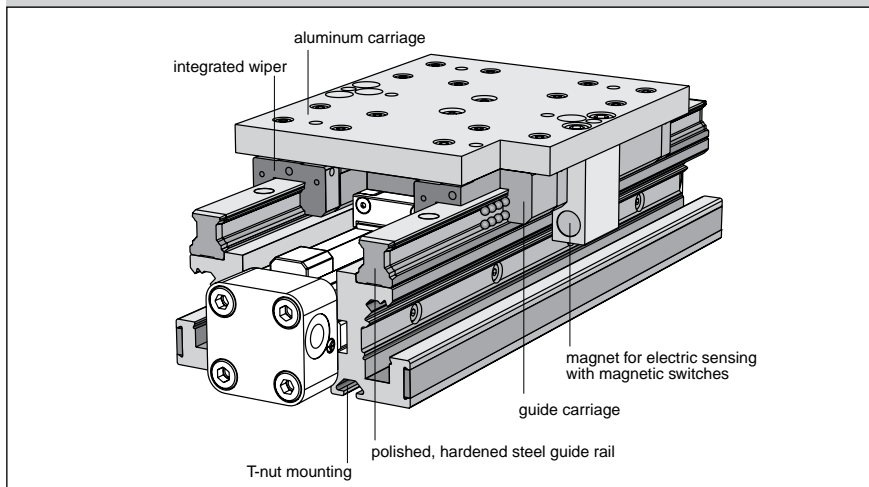

Features:

- Guide system:
 4-row recirculating ball bearing guide
- Polished and hardened steel guide rail
- For highest loads in all directions
- Highest precision
- Integrated wiper system
- Integrated grease nipples
- Any lengths of stroke up to 3700 mm (longer strokes on request)
- Anodized aluminum guide carriage - dimensions compatible with OSP guide GUIDELINE
- Maximum speed $v = 5 \text{ m/s}$



Loads, Forces and Moments

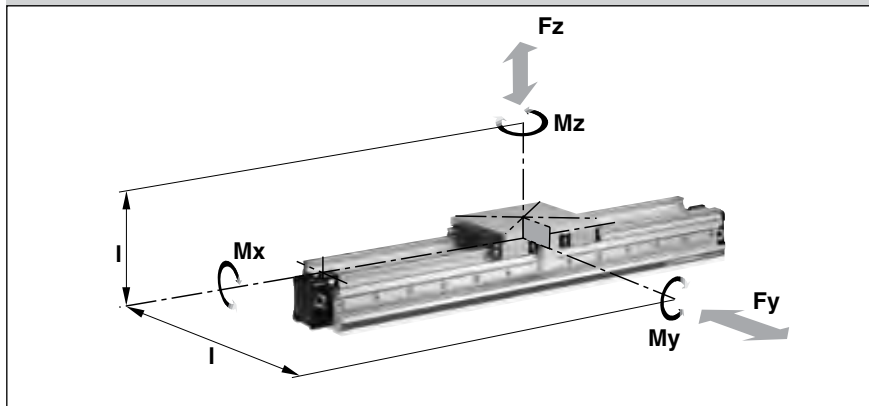

Technical Data

The table shows the maximum permissible loads. If multiple moments and forces act upon the cylinder simultaneously, the following equation applies:

$$\frac{M_x}{M_{x_{max}}} + \frac{M_y}{M_{y_{max}}} + \frac{M_z}{M_{z_{max}}} + \frac{F_y}{F_{y_{max}}} + \frac{F_z}{F_{z_{max}}} \leq 1$$

The sum of the loads should not >1

The table shows the maximum permissible values for light, shock-free operation which must not be exceeded even under dynamic conditions.

*** Please note:**

The mass of the carriage does not have to be added to the total moving mass when using the cushioning diagram.

Series	for linear drive	Max.moments (Nm)			Max.loads (N)		Mass of the linear drive with guide (kg)		Mass * guide carriage (kg)
		Mx	My	Mz	Fy	Fz	with 0 mm stroke	increase per 100 mm stroke	
HD 25	OSP-P25	260	320	320	6000	6000	3.065	0.924	1.289
HD 32	OSP-P32	285	475	475	6000	6000	4.308	1.112	1.367
HD 40	OSP-P40	800	1100	1100	15000	15000	7.901	1.748	2.712
HD 50	OSP-P50	1100	1400	1400	18000	18000	11.648	2.180	3.551

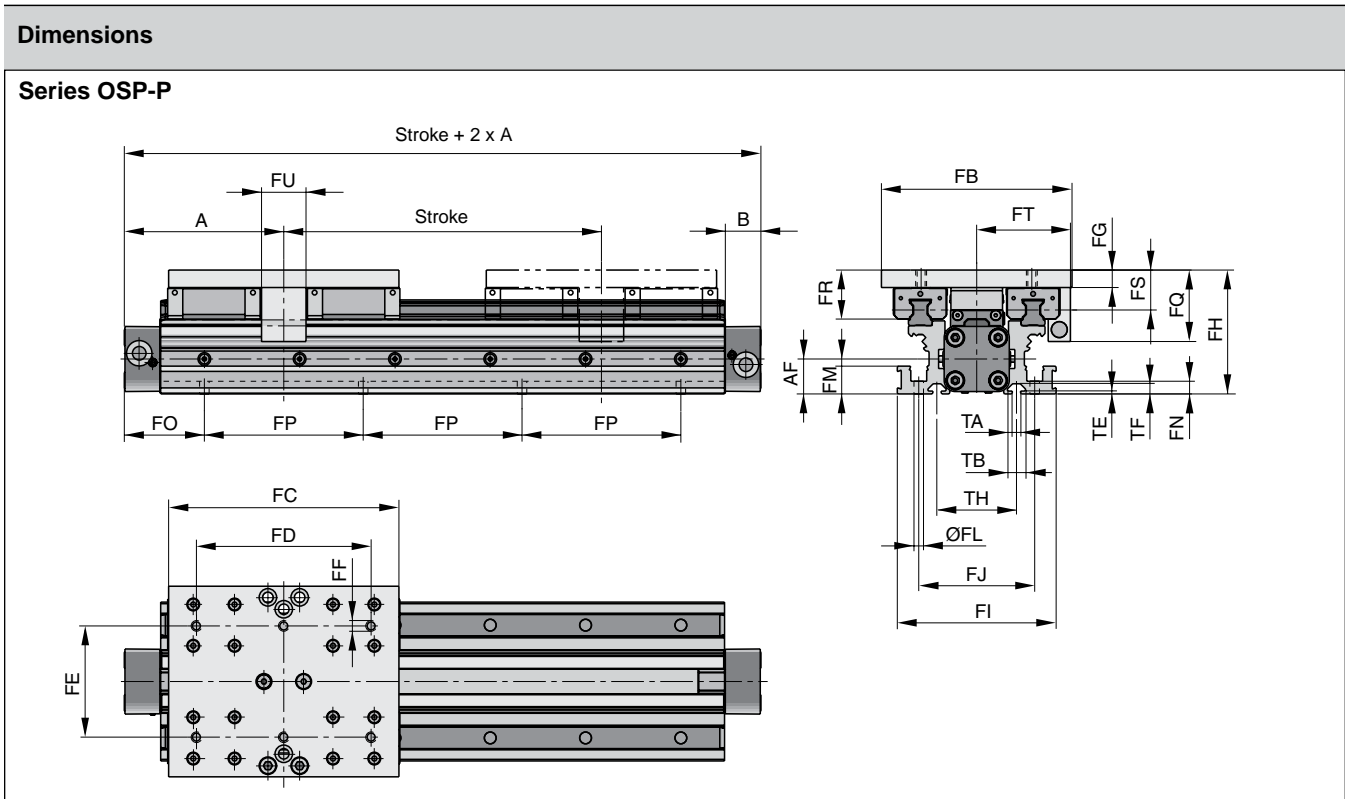

Note:

The HD heavy duty guide must be mounted on a flat surface for its entire length.

If T-grooves or T-bolts are used, the distance between them should not exceed 100 mm.

**Variable Stop
 Type VS25 to VS50**

The variable stop provides simple stroke limitation and can be supplied mounted on the right or left, as required.

For further information see following data sheets:

For dimensions and order instructions see page B95

For shock absorber selection see pages B71-B72

**Incremental displacement
 measuring system
 ORIGA-Sensoflex**

Series SFI-plus can be supplied mounted on the right or left, as required.

For further information see page B113

Arrangement of magnetic switches:

Magnetic switches can be fitted anywhere on either side.

For further information see following data sheets:

Magnetic Switches see pages B102-B108

Dovetail Cover see page B109

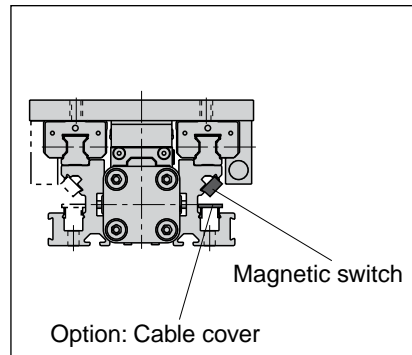
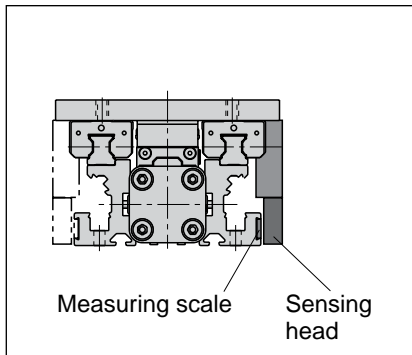
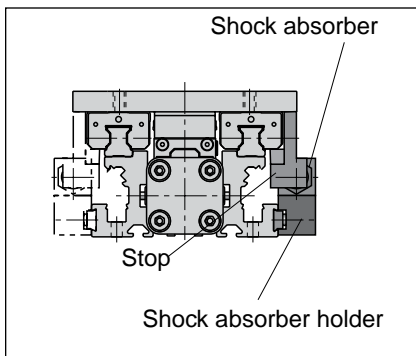

Dimensions

Dimension Table (mm)

Series	A	B	AF	FB	FC	FD	FE	FF	FG	FH	FI	FJ	ØFL
HD25	100	22	22	120	145	110	70	M6	11	78	100	73	6
HD32	125	25.5	30	120	170	140	80	M6	11	86	112	85	6
HD40	150	28	38	160	180	140	110	M8	14	108	132	104	7.5
HD50	175	33	48	180	200	160	120	M8	14	118	150	118	7.5

Series	FM	FN	FP	FQ	FR	FS	FT	FU	TA	TB	TE	TF	TH
HD25	17.5	8	100	45	31	25	59	28	5.2	11.5	1.8	6.4	50
HD32	17.5	8	100	45	31	25	63	30	5.2	11.5	1.8	6.4	60
HD40	22	10	100	58	40	31.5	76	30	8.2	20	4.5	12.3	66
HD50	22	10	100	58	44	35.5	89	30	8.2	20	4.5	12.3	76

Note:

the dimension FO is derived from the last two digits of the stroke:

Example:

Stroke 15**25** mm



For a cylinder OSP-P25 the adjacent table indicates that for x = 25 mm:

FO = 62.5 mm

FO				
OSP-P				
x	HD25	HD32	HD40	HD50
00	50.0	75.0	50.0	75.0
01	50.5	75.5	50.5	75.5
02	51.0	76.0	51.0	76.0
03	51.5	76.5	51.5	76.5
04	52.0	77.0	52.0	77.0
05	52.5	77.5	52.5	77.5
06	53.0	78.0	53.0	78.0
07	53.5	78.5	53.5	78.5
08	54.0	79.0	54.0	79.0
09	54.5	79.5	54.5	79.5
10	55.0	80.0	55.0	80.0
11	55.5	80.5	55.5	80.5
12	56.0	81.0	56.0	81.0
13	56.5	81.5	56.5	81.5
14	57.0	82.0	57.0	82.0
15	57.5	82.5	57.5	82.5
16	58.0	83.0	58.0	83.0
17	58.5	83.5	58.5	83.5
18	59.0	84.0	59.0	84.0
19	59.5	84.5	59.5	84.5
20	60.0	85.0	60.0	85.0
21	60.5	85.5	60.5	85.5
22	61.0	86.0	61.0	86.0
23	61.5	86.5	61.5	86.5
24	62.0	87.0	62.0	87.0
25	62.5	87.5	62.5	87.5
26	63.0	88.0	63.0	88.0
27	63.5	88.5	63.5	88.5
28	64.0	89.0	64.0	89.0
29	64.5	89.5	64.5	89.5
30	65.0	90.0	65.0	90.0
31	65.5	90.5	65.5	90.5
32	66.0	91.0	66.0	91.0
33	66.5	91.5	66.5	91.5

FO				
OSP-P				
x	HD25	HD32	HD40	HD50
34	67.0	42.0	67.0	92.0
35	67.5	42.5	67.5	92.5
36	68.0	43.0	68.0	93.0
37	68.5	43.5	68.5	93.5
38	69.0	44.0	69.0	94.0
39	69.5	44.5	69.5	94.5
40	70.0	45.0	70.0	95.0
41	70.5	45.5	70.5	95.5
42	71.0	46.0	71.0	96.0
43	71.5	46.5	71.5	96.5
44	72.0	47.0	72.0	97.0
45	72.5	47.5	72.5	97.5
46	73.0	48.0	73.0	98.0
47	73.5	48.5	73.5	98.5
48	74.0	49.0	74.0	99.0
49	74.5	49.5	74.5	99.5
50	75.0	50.0	75.0	100.0
51	75.5	50.5	75.5	100.5
52	76.0	51.0	76.0	101.0
53	76.5	51.5	76.5	101.5
54	77.0	52.0	77.0	102.0
55	77.5	52.5	77.5	102.5
56	78.0	53.0	78.0	103.0
57	78.5	53.5	78.5	103.5
58	79.0	54.0	79.0	104.0
59	79.5	54.5	79.5	104.5
60	80.0	55.0	80.0	105.0
61	80.5	55.5	80.5	105.5
62	81.0	56.0	81.0	106.0
63	81.5	56.5	81.5	106.5
64	82.0	57.0	82.0	107.0
65	82.5	57.5	82.5	107.5
66	83.0	58.0	83.0	108.0
67	83.5	58.5	83.5	108.5

FO				
OSP-P				
x	HD25	HD32	HD40	HD50
68	34.0	59.0	84.0	59.0
69	34.5	59.5	84.5	59.5
70	35.0	60.0	85.0	60.0
71	35.5	60.5	85.5	60.5
72	36.0	61.0	86.0	61.0
73	36.5	61.5	86.5	61.5
74	37.0	62.0	87.0	62.0
75	37.5	62.5	87.5	62.5
76	38.0	63.0	88.0	63.0
77	38.5	63.5	88.5	63.5
78	39.0	64.0	89.0	64.0
79	39.5	64.5	89.5	64.5
80	40.0	65.0	90.0	65.0
81	40.5	65.5	90.5	65.5
82	41.0	66.0	91.0	66.0
83	41.5	66.5	91.5	66.5
84	42.0	67.0	92.0	67.0
85	42.5	67.5	92.5	67.5
86	43.0	68.0	93.0	68.0
87	43.5	68.5	93.5	68.5
88	44.0	69.0	94.0	69.0
89	44.5	69.5	94.5	69.5
90	45.0	70.0	95.0	70.0
91	45.5	70.5	95.5	70.5
92	46.0	71.0	96.0	71.0
93	46.5	71.5	96.5	71.5
94	47.0	72.0	97.0	72.0
95	47.5	72.5	97.5	72.5
96	48.0	73.0	98.0	73.0
97	48.5	73.5	98.5	73.5
98	49.0	74.0	99.0	74.0
99	49.5	74.5	99.5	74.5



Dimensions – Variable Stop Type VS25 to VS50

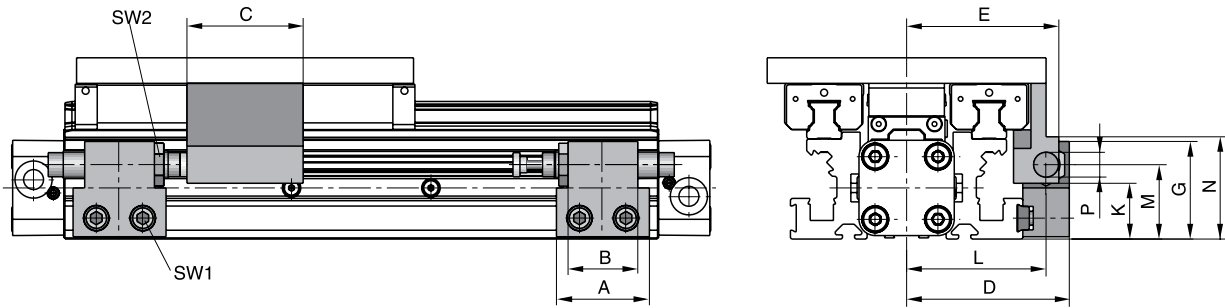

Dimension Table (mm) – Variable Stop Type VS25 to VS50

Series	Type	A	B	C	D	E	G	K	L	M	N	P	SW1	SW2
OSP-HD25	VS25	40	30	50	70	65.5	42	26	60	32	42	M12 x 1	5	16
OSP-HD32	VS32	60	40	54	73	71	44	28	63	34	53	M14 x 1.5	5	17
OSP-HD40	VS40	84	52	55	96	92	59	35	82	45	61	M20 x 1.5	5	24
OSP-HD50	VS50	84	-	60	107	105	66	37	89	49	66	M25 x 1.5	5	30

Order Information – Variable Stop Type VS25 to VS50

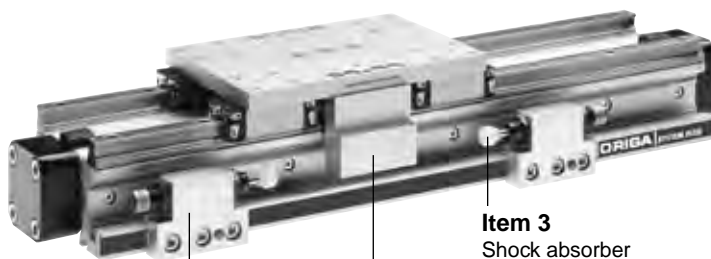

Item 2
Shock absorber holder
complete with fittings
– without shock absorber

Item 1
Stop complete
with fittings

Item 3
Shock absorber
with plastic cap

Shock Absorber Selection

For shock absorber selection in
dependence on mass and speed
see pages B82-B83

Order Instructions – Variable Stop Type VS25 to VS50

Item	Description	Size VS25		VS32		VS40		VS50	
		Type	Order No.	Type	Order No.	Type	Order No.	Type	Order No.
1	Stop, complete	-	21257	-	21258	-	21259	-	21260
2	Shock absorber holder, complete	-	21202	-	21203	-	21204	-	21205
3 *	Shock absorber, standard	SA12	7706	SA14	7708	SA20	7710	SAI25	7712
	Shock absorber, version S	SA12S	7707	SA14S	7709	SA20S	7711	SAI25S	7835

* Shock absorber with plastic cap (see pages B82-B83)



Intermediate Stop Module

The intermediate stop module ZSM allows the guide carriage to stop at any desired intermediate positions with high accuracy. It can be retrofitted. Depending on the application, i.e. the number of intermediate stops, one or more intermediate position stops can be used. The intermediate position stops can be retracted and extended without the need for the guide carriage to be moved back out of position. Therefore the guide carriage can be made to stop at the defined intermediate positions in any order.

ORIGA intermediate stop module ZSM:

- Allows stopping at any intermediate positions
- Intermediate position stops can be located steplessly anywhere along the whole stroke length
- Movement to the next position without reverse stroke
- Compact unit
- Cost-effective positioning module without electrical or electronic components
- Option: end stop with fine adjustment

Intermediate Stop Module Type ZSM..HD

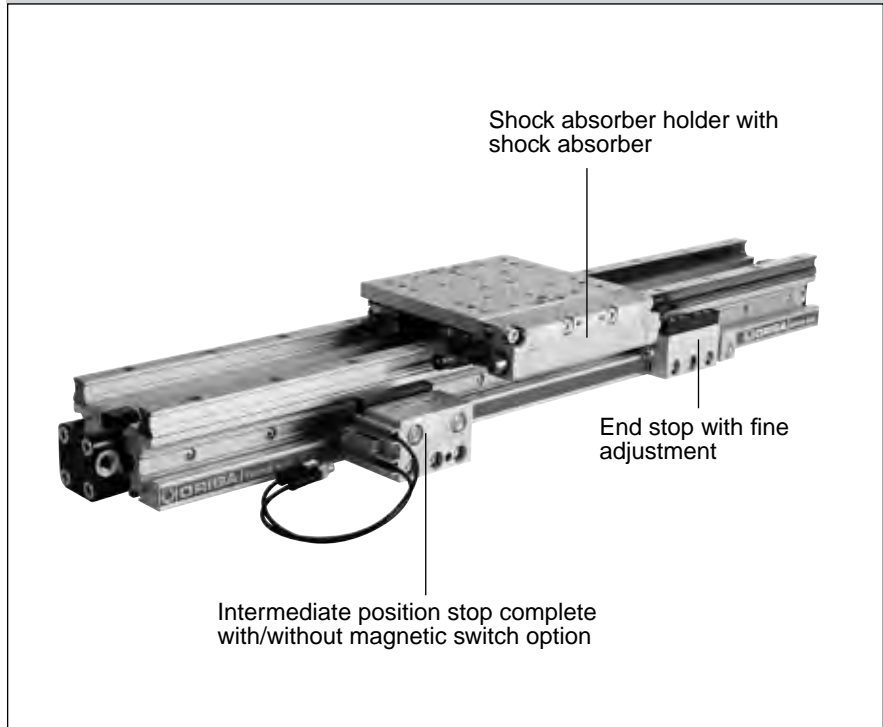

Technical Data

Temperature range	-10°C to +70°C
Operating pressure range	4 – 8 bar
Intermediate position grid	85 mm

Shock Absorber Type SA14S

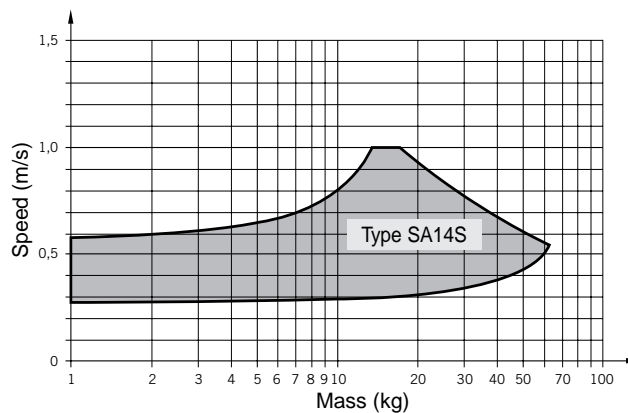

The values relate to an effective driving force of 250 N (6 bar)



Dimensions – intermediate stop module Type ZSM..HD

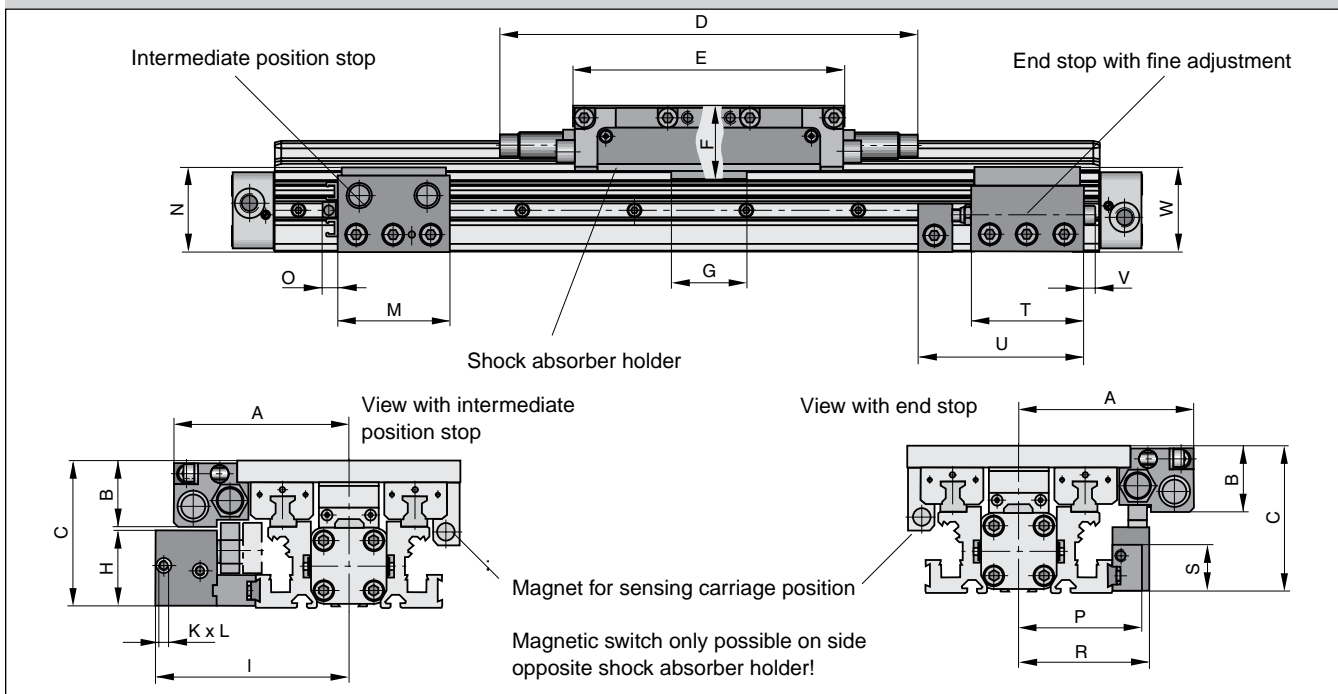

Dimension Table (mm) – intermediate Stop Module Type ZSM..HD

Series	A	B	C	D	E	F	G	H	I	K	L	M	N	O	P	R	S	T	U	V	W
ZSM25	94	35	78	224	145	39	40	41	104	M5	5	60	45	8	66	70	26	60	93	6	45

Shock Absorber Arrangement in Dependence on Direction of Movement

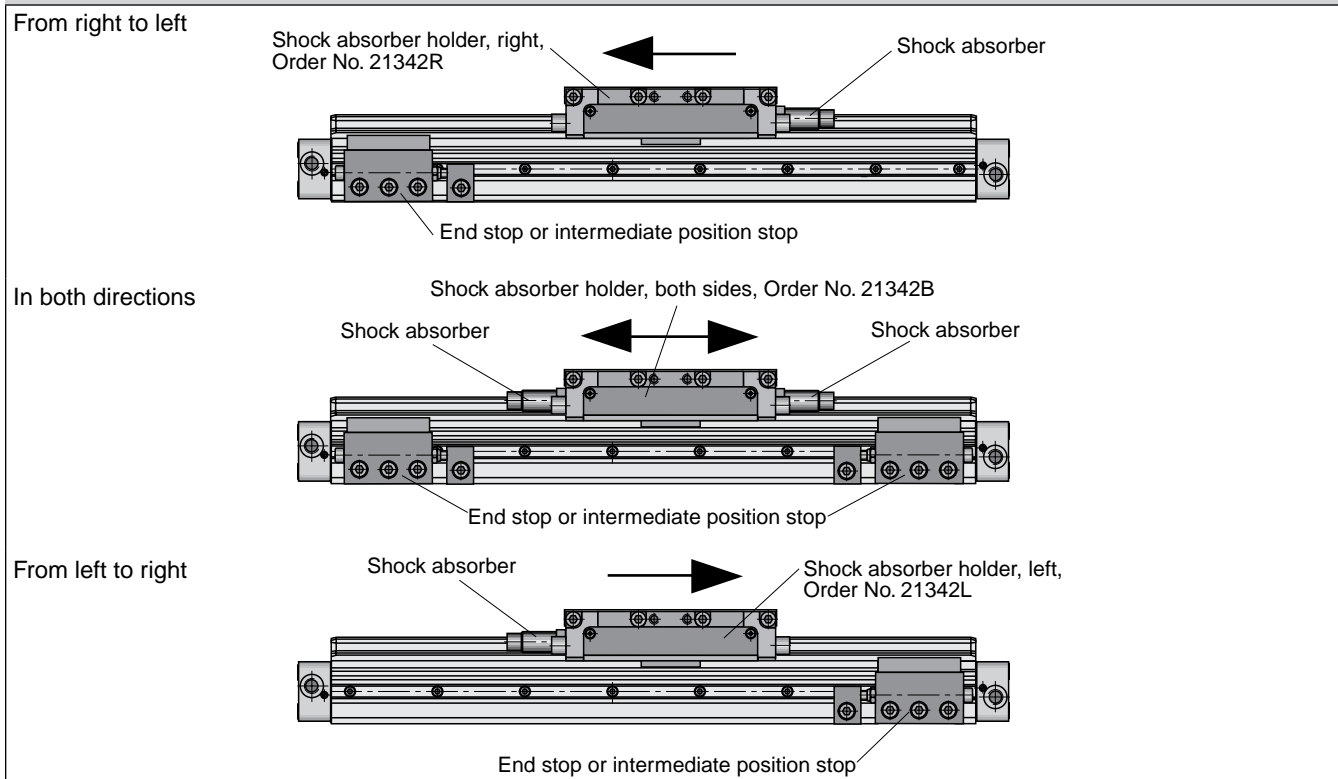

Order Instructions – intermediate Stop Module Type ZSM..HD

B

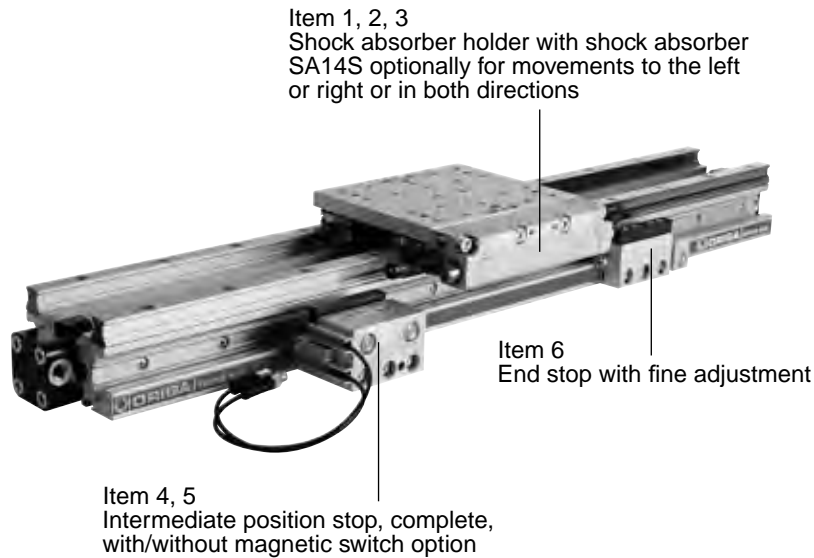

Illustration shows version with shock absorber holder for movement in both directions and magnetic switch option with T-slot switches.

Order instructions – intermediate stop module Type ZSM..HD

Item	Description	For intermediate stop module	Order-No.
1*	Shock absorber holder with shock absorber SA14S, both sides	ZSM25HD	21342B
2*	Shock absorber holder with shock absorber SA14S, left	ZSM25HD	21342L
3*	Shock absorber holder with shock absorber SA14S, right	ZSM25HD	21342R
4	Intermediate position stop complete, without magnetic switch option	ZSM25HD	21343
5	Intermediate position stop complete, with magnetic switch option	ZSM25HD	21344
6	End stop with fine adjustment	ZSM25HD	21346

* The shock absorbers are installed in the shock absorber holder and adjusted in our workshop.

Note:

For movement onwards from the intermediate position, the intermediate position stop must advance.
 The intermediate position stop can only advance if both cylinder chambers of the OSP-P cylinder are pressurized.

Ordering Instructions / Part Numbering System for OSP-P HD Series

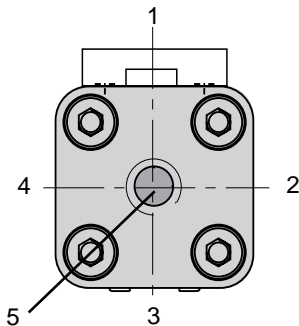
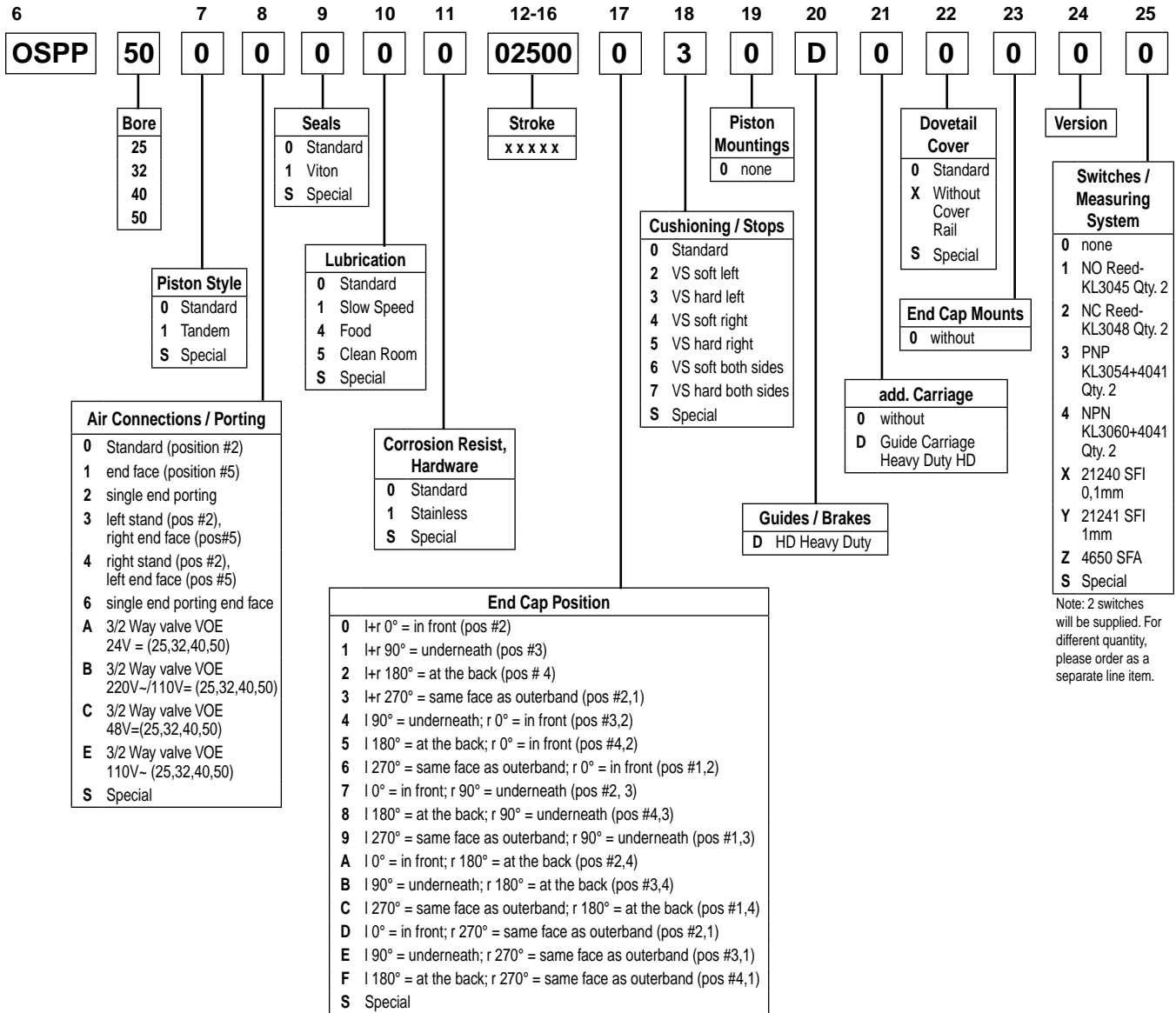

Note: Position #2 is the standard location.



B



OSP-P Sensors & Service Parts

B

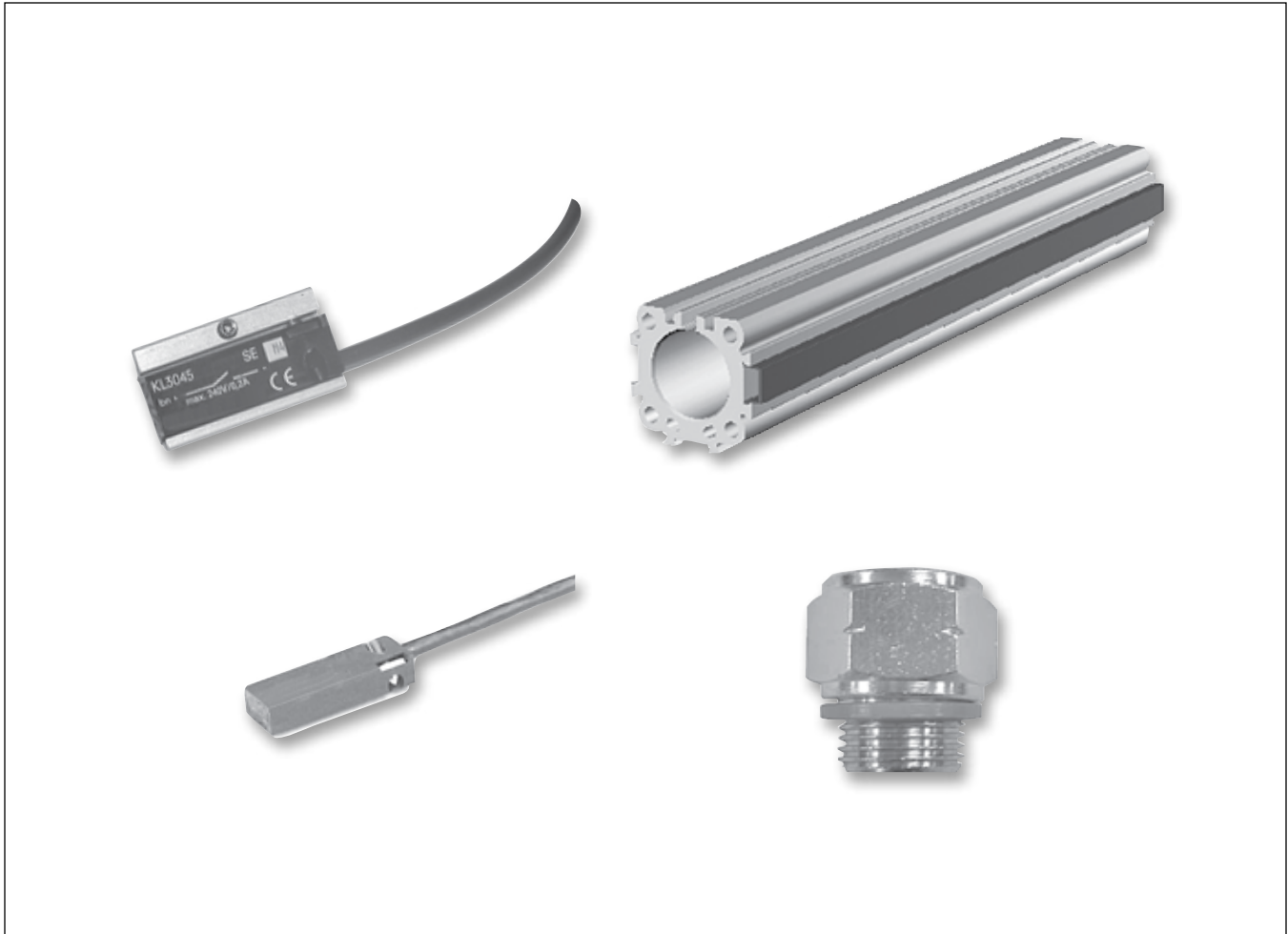

- Magnetic Switch, Standard Version..... B102-B104
- Magnetic Switch for T-Slot Mounting B105-B108
- Dovetail Cover.....B109
- Service Packs & Seal Kits.....B110



Linear Drive Accessories

ø 10-80 mm Magnetic Switches



B

For electrical sensing of the carrier position, e.g. at the end positions, magnetic switches may be fitted. Position sensing is contactless and is based on magnets fitted as standard to the carrier. A yellow LED indicates operating status.

The universal magnetic switches are suitable for all PARKER-ORIGA OSP-Actuators and aluminum profile rod type cylinders.

Piston, speed and switching distance affect signal duration and should be considered in conjunction with the minimum reaction time of ancillary control equipment.

$$\text{Min. reaction time} = \frac{\text{Switching distance}}{\text{Piston speed}}$$

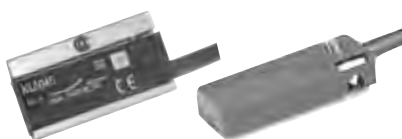

Characteristics			
Characteristics	Unit	Description	
Electrical Characteristics		Type RS	Type ES
Switching output		Reed	PNP, NPN
Operating voltage	V	10-240 AC/DC (NO) 10-150 AC/DC (NC)	10-30 DC
Residual voltage	V	< 3	< 3
Connection		Two wire	Three wire
Output function		normally open normally closed	normally open
Permanent current	mA	200	200
Max. switching capacity	VA (W)	10 VA	—
Power consumption without load	mA	—	< 20
Function indicator		LED, yellow	
Typical switching time	ms	On: < 2	On: < 2
Switch-off delay	ms	—	ca. 25
Pole reversal does not work		LED	—
Pole reversal protection		—	Built in
Short-circuit protection		—	Built in
Switchable capacity load		µF	0.1 at 100 Ω, 24
VDC			
Switching point accuracy	mm	± 0,2	
Switching distance	mm	ca. 15	ca. 15
Hysteresis for OSP	mm	ca. 8	ca. 3
Lifetime		3 x 10 ⁶ , up to 6 x 10 ⁶ cycles	Theoretically unlimited
Mechanical Characteristics			
Housing		Makrolon, smoke color	
Cable cross section	mm ²	2 x 0.14	3 x 0.14
Cable type *)		PVC	PUR, black
Bending radius fixed	mm	≥ 20	
moving	mm	≥ 70	
Weight (Mass)	kg	0.012	
Degree of protection	IP	67 to DIN EN 60529	
Ambient temperature range *) ¹⁾	°C °C	-25 other temperature ranges +80 on request	
Shock resistance	m/s ²	100 (contact switches)	500

*) other versions on request

¹⁾ for the magnetic switch temperature range, please take into account the surface temperature and the self-heating properties of the linear drive.

Type RS

In the type RS contact is made by a mechanical **reed switch** encapsulated in glass.

Direct connection with 2-pole cable, 5 m long, open ended (**Type RS-K**).

Type ES

In the type ES contact is made by an **electronic switch** – without bounce or wear and protected from pole reversal. The output is short circuit proof and insensitive to shocks and vibrations. Connection is by 3-pole connector for easy disconnection. Fitted with connection cable 100 mm long with connector.

A 5 m cable with connector and open end can be ordered separately, or use the Order No. for the complete Type ES with 5 m cable.

Magnetic Switches RS and ES

Electrical Service Life Protective Measures

Magnetic switches are sensitive to excessive currents and inductions. With high switching frequencies and inductive loads such as relays, solenoid valves or lifting magnets, service life will be greatly reduced.

With **resistive and capacitive loads** with high switch-on current, such as light bulbs, a protective resistor should be fitted. This also applies to long cable lengths and voltages over 100 V.

In the switching of inductive loads such as relays, solenoid valves

and lifting magnets, voltage peaks (transients) are generated which must be suppressed by protective diodes, RC loops or varistors.

Connection Examples

- Load with protective circuits
- (a) Protective resistor for light bulb
 - (b) Freewheel diode on inductively
 - (c) Varistor on inductively
 - (d) RC element on inductively

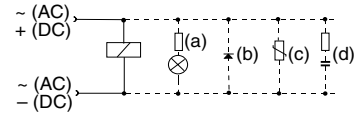

For the type ES, external protective circuits are not normally needed.

B

Electrical Connection, Type RS

Normally closed (NC)

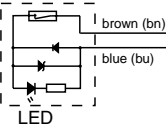

Normally open (NO)

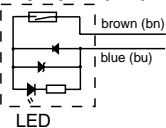

Dimensions (mm) – Type RS-K

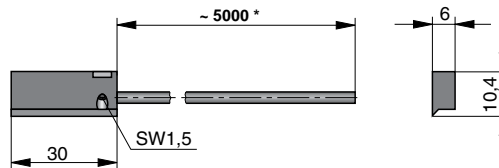

* Length with possible minus tolerance, see chart below

Electrical Connection, Type ES

Standard Version: Type PNP

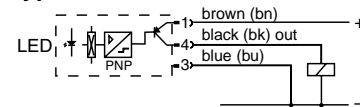

Optional Version Type NPN

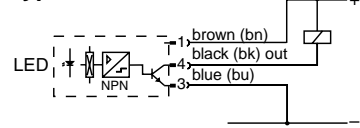

Dimensions (mm) – Type ES-S

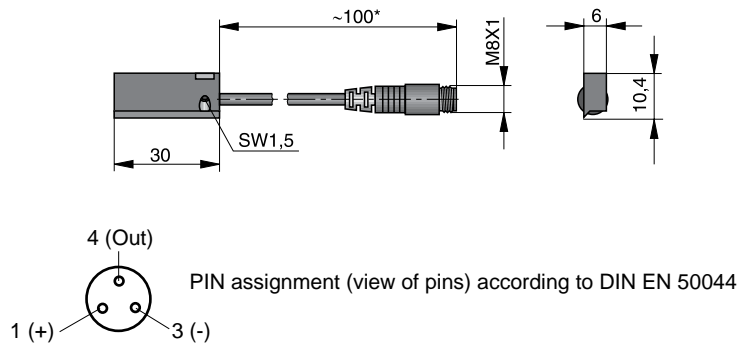

* Length with possible minus tolerance, see chart below

Length of connection cable with length tolerance

Magnetic Switch Order No.	Nominal cable length	Length tolerance
KL3045	5000 mm	-50 mm
KL3048	5000 mm	-50 mm
KL3054	100 mm	-20 mm
KL3060	145 mm	±5 mm

Dimensions & Ordering Information

OSP-P Sensors

Dimensions Series OSP-P10

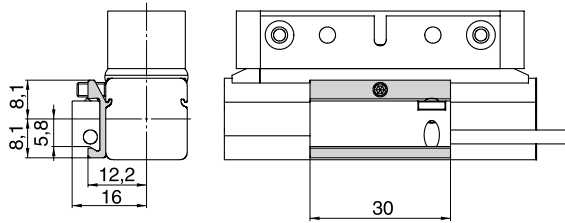

Note:
Sensors can not be mounted directly opposite of the carrier

Dimensions Series OSP-P16 to 80

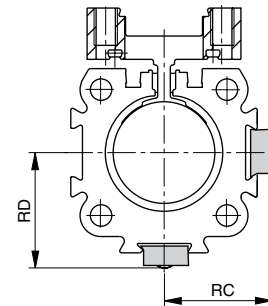

B

Dimension Table (mm) and Order Instructions

Series	Dimensions		Order No.						Adapter only for OSP-P10)
	RC	RD	RS closer Normally open	RS opener Normally closed	ES PNP	NPN	ES compl. with 5 m cable		
			Type:	Type:	Type:	Type:	Type:	Type:	
OSP-P10	–	–	Type: RS-K KL3045	Type: RS-K KL 3048	Type: ES-S KL 3054	Type: ES-S KL 3060	Type: ES-S KL 3054 + 4041	Type: ES-S KL 3060 + 4041	20968
OSP-P16	20	20.5							please order separately
OSP-P25	25	27							
OSP-P32	31	34							
OSP-P40	36	39							
OSP-P50	43	48							
OSP-P63	53	59							
OSP-P80	66	72							
Cable 5 m with connector and with open end for magnetic switches Type ES-S					4041				

Characteristics			
Characteristics	Unit	Description	
Electrical Characteristics		Type RST	Type EST
Switching output		Reed	PNP
Operating voltage	V	10-30 AC/DC	10-30 DC
Ripple		-	≤10%
Voltage drop	V	≤3	≤2
Electrical configuration		2 wire	3 wire
Output function		normally open normally closed	normally open
Permanent current	mA	≤ 100	≤ 100
Breaking capacity	W	≤ 6 peak	-
Power consumption, at $U_B = 24V$, switched on, without load	mA	-	≤ 10
Function indicator		LED, yellow (not for normally closed)	
Response time	ms	≤2	≤0.5
Sensitivity	mT	2–4	2–4
Time delay before availability	ms	-	≤2
Reverse polarity prot.		yes	yes
Short-circuit protection		no	yes (pulsed)
Switchable capacity load	μF	0.1 at 100Ω, 24 VDC	
Switching frequency	Hz	≤400	≤5 k
Repeatability	mm	≤0.2	≤0.2
Hysteresis	mm	≤1.5	≤1.5
EMC	EN	60947-5-2	
Lifetime		≥35 Mio. cycles with PLC load	unlimited
Power-up pulse suppression		-	yes
Protection for inductive load		-	yes
Mechanical Characteristics			
Housing		Plastic/ PA66 + PA6I red	
Cable cross section	mm ²	2x0.14	3x0.14
Cable type		PUR, black	PUR, black
Bending radius	mm	≥36	≥30
Weight	kg	ca. 0.030 RST-K ca. 0.010 RST-S	ca. 0.030 EST-K ca. 0.010 EST-S
Degree of protection	IP	67 to EN 60529	
Ambient temperature range ¹⁾	°C	-25 to +80	-25 to +75 at $U_B=10 - 30 V$ -25 to +80 at $U_B=10 - 28 V$
– with adapter	°C	-25 to +60	
Adapter tightening torque	Nm	0.15 (tightening torque of screwing adapter on to magnetic switch)	
Shock resistance			
Vibration to EN 60068-2-6	G	15, 11 ms, 10 to 55 Hz, 1 mm	
Shock to EN 60068-2-27 G	50, 11 ms		
Bump to EN 60068-2-29 G	30, 11 ms	1000 bumps each axis	

Linear Drive Accessories

∅ 10-80 mm Magnetic Switches for T-Slot



Series RST
EST

Magnetic switches are used for electrical sensing of the position of the piston, e.g. at its end positions. They can also be used for sensing of intermediate positions.

Sensing is contactless, based on magnets which are built-in as standard. A yellow LED indicates operating status.

The universal magnetic switches are suitable for all PARKER-ORIGA OSP-Actuators and aluminum profile rod type cylinders.

¹⁾ for the magnetic switch temperature range, please take into account the surface temperature and the self-heating properties of the linear drive.



B

Type RST

In the type RST contact is made by a mechanical **reed switch** encapsulated in glass.

Type EST

In the type EST contact is made by an **electronic switch** – without bounce or wear and protected from pole reversal. The output is short circuit proof and insensitive to shocks and vibrations. Connection is by 3-pole connector for easy disconnection. Fitted with connection cable 100 mm long with connector.

A 5 m cable with connector and open end can be ordered separately, or use the Order No. for the complete Type ES with 5 m cable.

Magnetic Switches RST and EST

Electrical Service Life Protective Measures

Magnetic switches are sensitive to excessive currents and inductions. With high switching frequencies and inductive loads such as relays, solenoid valves or lifting magnets, service life will be greatly reduced.

With **resistive and capacitive loads** with high switch-on current, such as light bulbs, a protective resistor should be fitted. This also applies to long cable lengths and voltages over 100 V.

In the switching of inductive loads such as relays, solenoid valves

and lifting magnets, voltage peaks (transients) are generated which must be suppressed by protective diodes, RC loops or varistors.

Connection Examples

- Load with protective circuits
- (a) Protective resistor for light bulb
- (b) Freewheel diode on inductively
- (c) Varistor on inductively
- (d) RC element on inductively

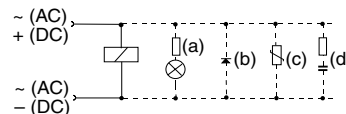

For the type EST, external protective circuits are not normally needed.

B

Electrical Connection Type RST-K

Normally closed

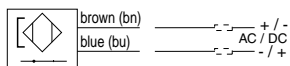

Normally open

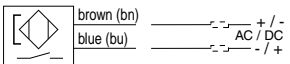

Electrical Connection Type EST-K

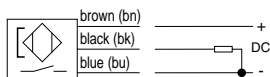

Electrical Connection Type RST-S

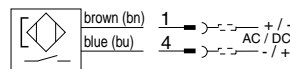

Electrical Connection Type EST-S

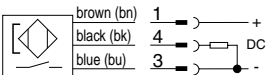

Magnetic Switches – Dimensions

Dimensions (mm) – Type RST-K, EST-K

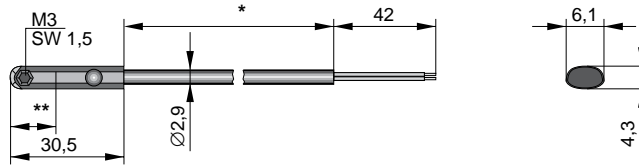

- * Cable lengths available: 5000 mm ± 75 mm
2000 mm ± 40 mm
- ** Switching point: Type RST-K Normally closed 14 mm
Type RST-K Normally open 12.3 mm
Type EST-K Normally open 8.1 mm

Dimensions (mm) – Type RST-S, EST-S

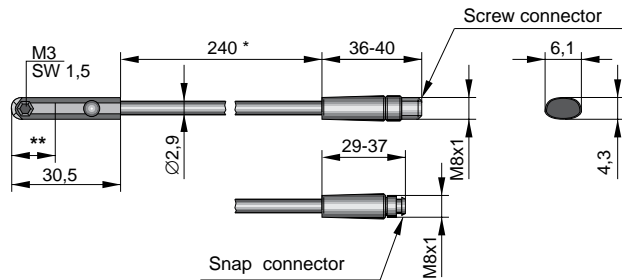

- * ± 6 mm
- ** Switching point: Type RST-K Normally closed 14 mm
Type RST-K Normally open 12.3 mm
Type EST-K Normally open 8.1 mm

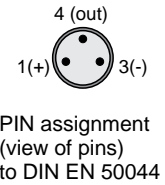

Installation

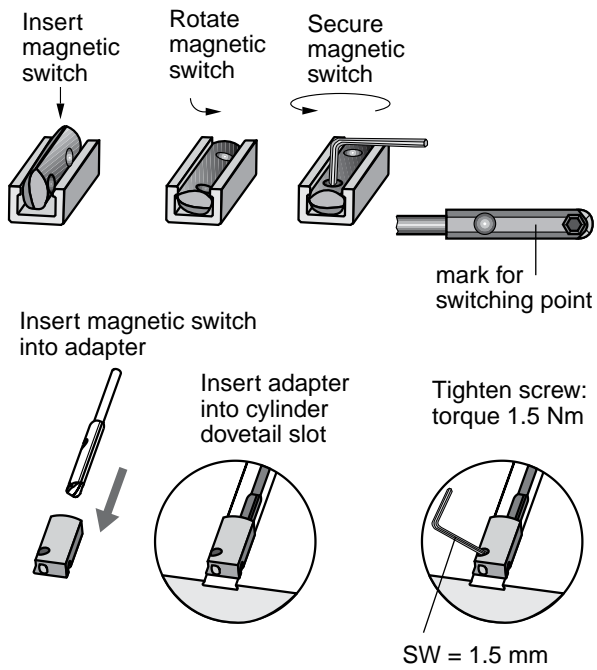

Dimensions of Adapter for Magnetic Switch

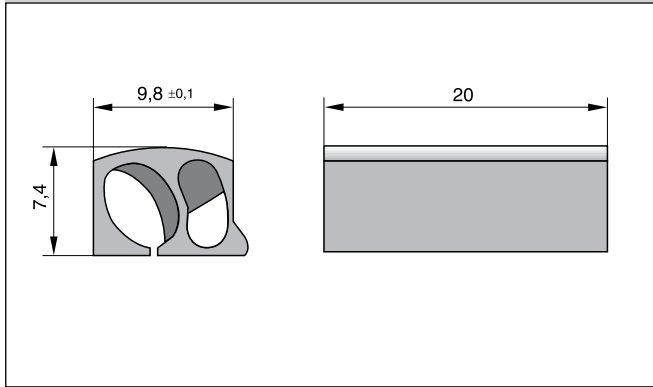

B

Magnetic Switches – Ordering**OSP-P Sensors****B**

Order Instructions			
Version	Voltage	Type	Order No.
Magnetic switch, reed contact, normally open, LED indicator, cable 2 m	10-30 V AC / DC	RST-K	KL 3301
Magnetic switch, reed contact, normally open, LED indicator, cable 5 m	10-30 V AC / DC	RST-K	KL 3300
Magnetic switch, reed contact, normally open, snap connector M8, LED indicator, cable 0.24 m	10-30 V AC / DC	RST-S	KL 3302
Magnetic switch, reed contact, normally open, screw connector M8, LED indicator, cable 0.24 m	10-30 V AC / DC	RST-S	KL 3303
Magnetic switch, reed contact, normally closed, cable 5 m	10-30 V AC / DC	RST-K	KL 3305
Magnetic switch, electronic, PNP LED indicator, cable 2 m	10-30 V DC	EST-K	KL 3308
Magnetic switch, electronic, PNP LED indicator, cable 5 m	10-30 V DC	EST-K	KL 3309
Magnetic switch, electronic, PNP snap connector M8, LED indicator	10-30 V DC	EST-S	KL 3312
Magnetic switch, electronic, PNP screw connector M8, LED indicator	10-30 V DC	EST-S	KL 3306

Included in delivery: 1 magnetic switch
1 adapter for dovetail groove mounting

Accessories		
Description	Type	Order No.
Cable M8, 2.5 m without lock nut	KS 25	KY 3240
Cable M8, 5.0 m without lock nut	KS 50	KY 3241
Cable M8, 10.0 m without lock nut	KS 100	KY 3140
Cable M8, 2.5 m with lock nut	KSG 25	KC 3102
Cable M8, 5.0 m with lock nut	KSG 50	KC 3104
Adapter for dovetail groove (pack of 10)		KL 3333

Dimensions (mm)

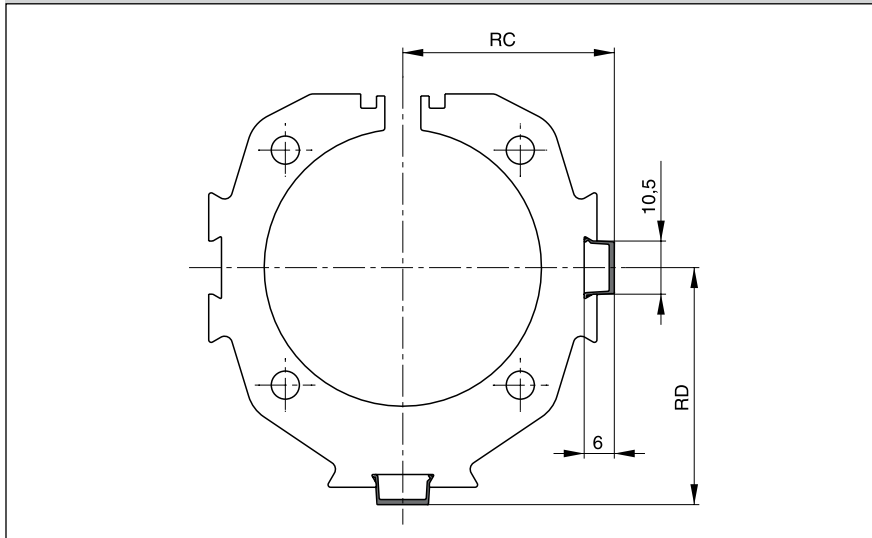

Linear Drive Accessories

∅ 16-80 mm
Dovetail Cover



B

Dimension Table (mm) and Order Instructions

Series	Dimensions (mm)		Order No.
	RC	RD	
OSP-P16	18.5	19	13039 Minimal length: 1m Max. profile length: 2m Multiple profiles can be used.
OSP-P25	23.5	25.5	
OSP-P32	29.5	32	
OSP-P40	34.5	37.5	
OSP-P50	41.5	46.5	
OSP-P63	51.5	57.5	
OSP-P80	64.5	70.5	

For clean guidance of magnetic switch cables along the cylinder body.

Contains a maximum of 3 cables with diameter 3 mm.

Material: Plastic

Color: Red

Temperature Range: -10 to +80°C

Metric Conversion Fittings

Order Number	Port Size	Bore Size
2521-1/8-02	G1/8 to 1/8" NPT	P25
2521-1/4-04	G1/4 to 1/4" NPT	P32, P40, P50
2521-3/8-06	G3/8 to 3/8" NPT	P63
2521-1/2-08	G1/2 to 1/2" NPT	P80



Service Packs

		Bore Sizes							
		16mm	25mm	32mm	40mm	50mm	63mm	80mm	
B	BUNA Service Pack Single Piston	Part Number	11111	11112	11113	11114	11115	11116	11118
	Viton Service Pack Single Piston	Part Number	11121	11122	11123	11124	11125	11126	11128
	BUNA Service Pack Single Piston - Slow Speed Grease	Part Number	11131	11132	11133	11134	11135	11136	11138
	Viton Service Pack Single Piston - Slow Speed Grease	Part Number	11141	11142	11143	11144	11145	11146	11148

*Behind part number, please add stroke length in mm

Service Pack Information

Service Packs, containing all the components necessary to completely rebuild a Parker-Origa rodless cylinder, are available. Each pack contains a complete seal kit, inner and outer bands, Parker-Origa grease tube, cleaning tool and repair instructions. It's all packaged in an easy-to-ship, easy-to-store box clearly labeled to indicate the cylinder type, bore and stroke for which it is intended. Contact your local Parker-Origa distributor for more information.

Seal Kits

		Bore Sizes						
		16mm	25mm	32mm	40mm	50mm	63mm	80mm
BUNA Seal Kit - Standard Cylinder	Part Number	11052	11053	11054	11055	11056	11057	11058
Viton Seal Kit - Standard Cylinder	Part Number	11059	11060	11061	11062	11063	11064	11065
Seal Kit - Sideline Carriage	Part Number	11066	11067	11068	11069	11070	–	–
Seal Kit Active Brake - Standard Cylinder	Part Number	–	11822	11823	11824	11825	11826	11827
Seal Kit - Multibrake	Part Number	–	11089	11090	11091	11092	11093	–



ORIGA-SENSOFLEX Displacement Measuring System for Cylinder Series OSP-P

B



Overview.....	B112
Technical Data SFI-plus.....	B113
Dimensions SFI-plus	B114
Order Information	B115



ORIGA- Sensoflex

Displacement measuring system
for automated movement

Series SFI-plus
(incremental measuring system)

for cylinder series

- OSP-P...

Characteristics

- Contactless magnetic displacement measurement system
- Displacement length up to 32 m
- Resolution 0.1 mm (option: 1 mm)
- Displacement speed up to 10 m/s
- For linear and non-linear rotary motion
- Suitable for almost any control or display unit with a counter input



The SFI-plus magnetic displacement measuring system consists of 2 main components.

- **Measuring Scale**

Self-adhesive magnetic measuring scale

- **Sensing Head**

Converts the magnetic poles into electrical signals which are then processed by counter inputs downstream

(e.g. PLC, PC, digital counter)

B

Characteristics			
Characteristics	Unit	Description	
Type		21210	21211
Output Function			
Resolution	mm	0.1	1
Pole lengths magnetic scale	mm	5	
Maximum speed	m/s	10	
Repeat accuracy		± 1 Increment	
Distance between sensor and scale	mm	≤ 4	
Tangential deviation		≤ 5°	
Lateral deviation	mm	≤ ± 1.5	
Switching output		PNP	
Electrical Characteristics			
Operating voltage U_b	V DC	18 – 30	
Voltage drop	V	≤ 2	
Continuous current for each output	mA	≤ 20	
Power consumption at $U_b = 24V$, switched on, without load	mA	≤ 50	
Short-circuit protection		yes	
Reverse polarity protection			yes
Protection from inductive load		yes	
Power-up pulse suppression		yes	
EMC			
Electrostatic discharge immunity	kV	6, B, to EN 61000-4-2	
Electromagnetic field immunity	V/m	10, A, to EN61000-4-3	
Electrical fast transient/burst immunity (for signal connections)	kV	1, B, to EN 61000-4-4	
Electrical fast transient/burst immunity (for DC connections)	kV	2, B, to EN 61000-4-4	
Surge immunity (for signal connections)	kV	1, B, to EN 61000-4-5	
Surge immunity (for DC connections)	kV	0,5, B, to EN 61000-4-5	
Immunity to conducted disturbances	V	10, A, to EN 61000-4-6	
Power frequency magnetic field immunity at 50 Hz	A/m	30, A, to EN 61000-4-8	
Emission standard for residential		to EN 61000-6-4	
Radio disturbance characteristics		to EN 55011, Group 1, A	
Mechanical Characteristics			
Housing		Aluminum	
Cable length	m	5.0 – fixed, open end	
Cable cross section	mm ²	4 x 0.14	
Cable type		PUR, black	
Bending radius	mm	≥ 36	
Weigth (mass)	kg	ca. 0.165	
Environmental Conditions / Shock Resistance			
Degree of protection	IP	67 to EN60529	
Ambient temperature range	°C	-25 to +80	
Broad-band random vibration to EN 60068-2-64	g	5, 5 Hz to 2 kHz, 0.5 h each axis	
Vibration stress to EN 60068-2-6	g	12, 10 Hz to 2 kHz, 2 mm, 5 h each axis	
Shock to EN 60068-2-27	g	100, 6 ms, 50 bumps each axis	
Bump to EN 60068-2-29	g	5, 2 ms, 8000 bumps each axis	

Displacement Measuring System

for automated movement

ORIGA-Sensoflex (incremental displacement measuring system)

Series SFI-plus for cylinder series

- OSP-P...

Note:

For combinations Active Brake AB + SFI-plus + Magnetic Switch contact our technical department please.



B

Sensoflex – Dimensions

Sensing Head

The sensing head provides two pulsating, 90° out of phase counter signals (phase A/B) with a 0.4 mm resolution (option 4 mm). External processing can improve the resolution to 0.1 mm (option 1 mm). The counting direction can be determined automatically from the phase variance of the counter signals.

Dimensions (mm) – Sensing Head

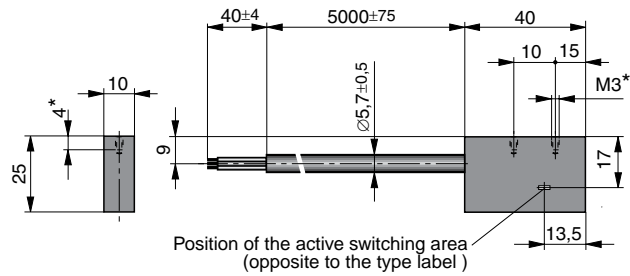

* Maximum thread depth 4mm

Output signal – Sensing Head

U _a = U _e	Phase B	U _{a1}	0°	
	Phase A	U _{a2}	90°	

Electrical Connection

Color	Description
bn = brown	+ DC
bu = blue	- DC
bl = black	Phase A
wt = white	Phase B

SFI-plus mounted on a rodless cylinder series OSP-P

The SFI-plus system can be mounted directly on a rodless OSP-P cylinder with the special mounting kit. The position of the sensing head is generally 90° to the carrier.



Dimensions – in combination with OSP-P cylinders

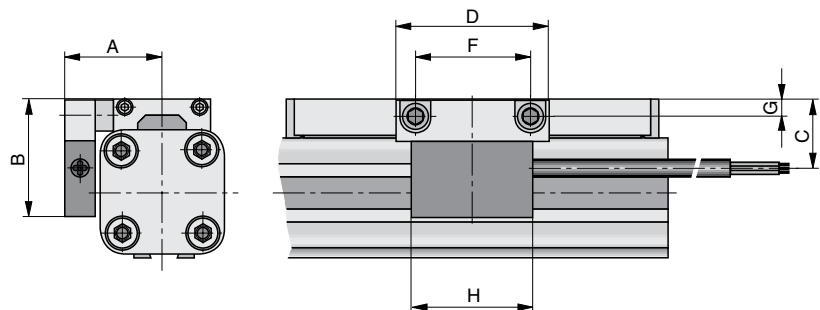

Dimension Table (mm)

Series	A	B	C	D	F	G	H
OSP-P25	32	39	23	50	38	5.5	40
OSP-P32	37.5	46	30	50	38	6.5	40
OSP-P40	42.5	50	34	50	38	6.5	40
OSP-P50	49.5	55	39	50	38	6.5	40
OSP-P63	59.5	65	49	50	38	10	40
OSP-P80	72.5	80	64	50	38	12	40

Combinations consisting of SFI-plus and OSP-P Cylinders with guides are available on request.

B

Sensoflex – Ordering Information

Order instructions	
Description	Order No.
Sensing head with measuring scale – Resolution 0.1 mm (scale length = required measuring distance + a minimum of – see table below)	21240
Option: Sensing head with measuring scale – Resolution 1 mm (scale length = required measuring distance + a minimum of – see table below)	21241
Sensing head – Resolution 0.1 mm (spare part)	21210
Option: Sensing head – Resolution 1 mm (spare part)	21211
Measuring scale per meter (spare part)	21235
Mounting kit for OSP-P25	21213
Mounting kit for OSP-P32	21214
Mounting kit for OSP-P40	21215
Mounting kit for OSP-P50	21216
Mounting kit for OSP-P63	21217
Mounting kit for OSP-P80	21218



* Overall length of the measuring scale results from stroke length of the cylinder + dead length
 Dead length for linear drives series OSP-P see table.

Series	Dead length (mm)
OSP-P 25	154
OSP-P 32	196
OSP-P 40	240
OSP-P 50	280
OSP-P 63	350
OSP-P 80	422

Example:

Cylinder OSP-P, Ø25 mm, stroke length 1000 mm

$$\begin{array}{rcl}
 \text{dead length} & + & \text{stroke length} & = & \text{overall length of the measuring scale} \\
 \mathbf{154\text{ mm}} & + & \mathbf{1000\text{ mm}} & = & \mathbf{1154\text{ mm}}
 \end{array}$$

Notes

B



GDL Aluminum Roller Guides



C

The Guideline Concept.....	C2	Technical information.....	C10-C13
The Guideline System	C3	Ordering Information.....	C14
Overview & Descriptions	C4	GDL Application Sheet	C15
General Facts & Dimensions	C5		
Load and Moment Ratings	C6		
GDL Roller Guides / Accessories.....	C7		
Wipers / Butt-jointed Rail Options.....	C8		
Conversion Tables	C9		



Features

Light, Smooth and FAST

Aluminum roller guides in a cutting machine for spectacle lenses. Both the work piece carriers and the motorized X - Y table axis are equipped with roller guides. The smooth operation and precision of the equipment ensures a fine cutting action.



Aluminum roller guides in an automatic vibrator for flattening printed sheets of paper. To guarantee even pressure on the sheets of paper, the roller bridge is supported by precision roller guides.

(Baumann company photo)



Handling units for medical equipment. Smooth, easy movement with guideline roller guides.

(Dräger company photo)



Aluminum roller guides in the sliding carriage of a machine for producing cables. The projecting arm of the carriage is guided by two double rails each with two roller cassettes and can be moved manually with minimal force because of the low friction properties.

(Kabelmat company photo)



Single rail and roller shoe versions of the aluminum roller guide in a handling arrangement for stacks of paper. Various fittings and limit stops for stacking are moved on two axes horizontally and vertically. The robustness and reliability of the roller guides allows for continuous operation under high load conditions.

(Solms company photo)



- Light weight (anodized aluminum)
- Smooth and quiet operation
- Speeds up to 10 m/s
- Acceleration/deceleration up to 40 m/s²
- Loading from any direction
- Permanently lubricated guidance system
- Broad product range in various series high performance, standard and stainless steel versions
- High load and moment capacities
- Very cost effective
- Flexible mounting dimensions



Features

GDL Linear Guides Offer a Variety of Series and Options — High Performance... “Smooth Guidance”

Aluminum roller guides provide smooth operation and high load carrying capacity for industrial automation.

By the use of lightweight aluminum components the moving masses are minimized, travel speeds are increased and actuation energy is saved.

Aluminum roller guides are designed to carry medium weight loads economically. Their smooth action and speeds up to 10 m/s make them ideal for widespread use in many areas of application.

Aside from a main featured High Performance guide, others such as the Standard, Corrosion Resistant, High Dynamics and Grease-free versions are also available.

Aluminum roller guides are available in sizes 12, 15, 20, 25, 35 and 45mm. Rail lengths are from 200 mm to 4000 mm. For longer travel lengths, guide rails can be butt-jointed together.

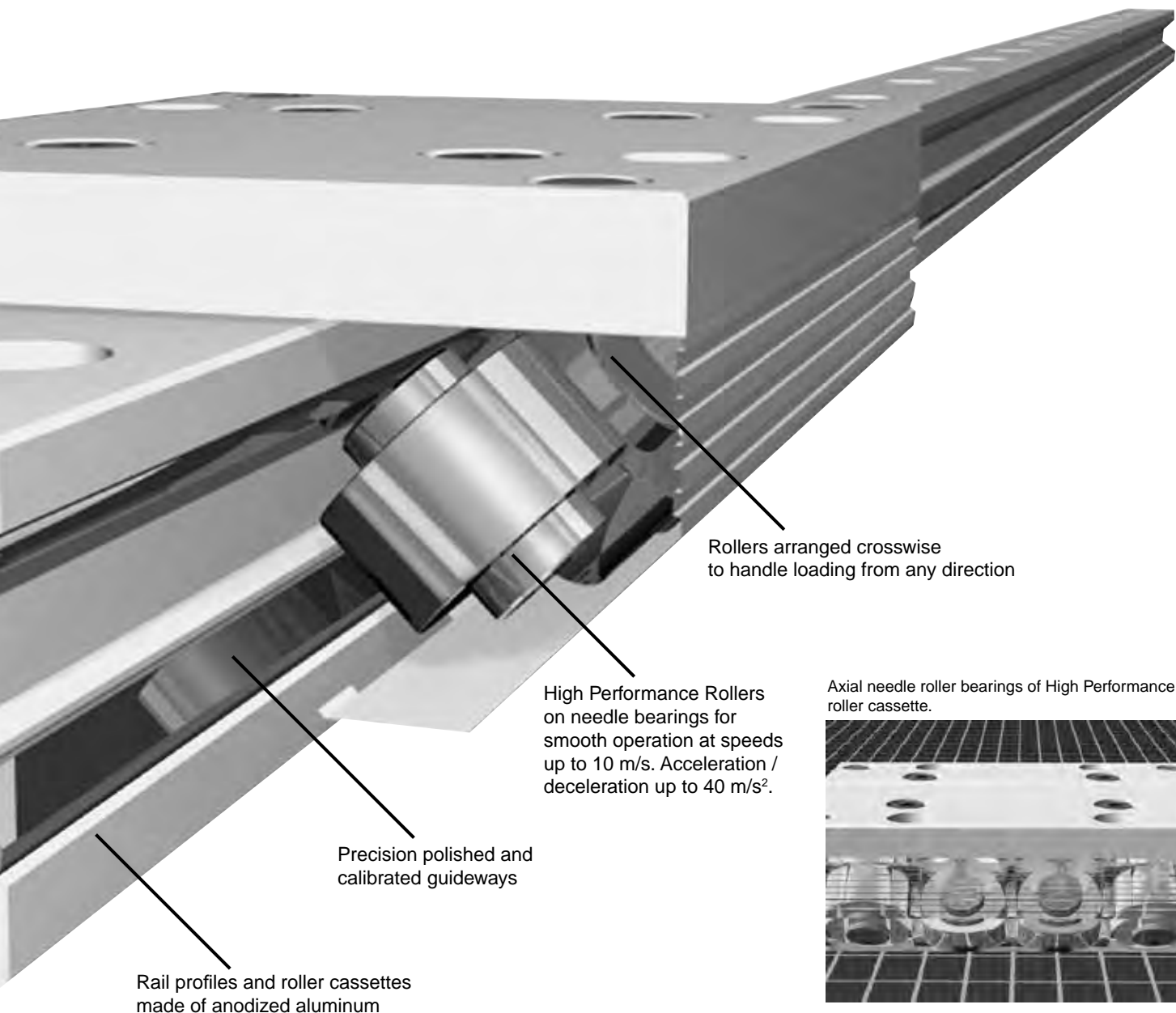

Rollers arranged crosswise to handle loading from any direction

High Performance Rollers on needle bearings for smooth operation at speeds up to 10 m/s. Acceleration / deceleration up to 40 m/s².

Precision polished and calibrated guideways

Rail profiles and roller cassettes made of anodized aluminum

Axial needle roller bearings of High Performance roller cassette.

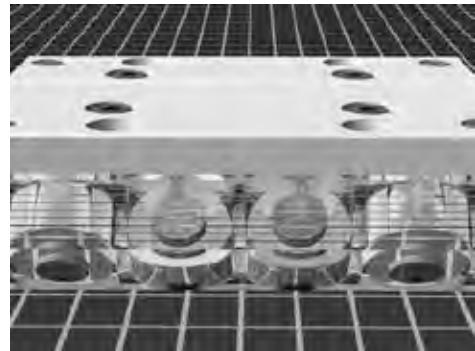

GDL Product Line Overview

Characteristic	Unit	Description
Full profile wipers		Rollershoes and cassette are provided with snap-on full profile wipers. The snap-on full profile wipers are easily replaceable with available wipers kits. See page 8 for respective wiper kit order numbers.
Mounting		Rollershoes and cassettes use ISO screw quality 8.8 and DIN 433 washers. ISO screw quality 8.8 is recommended for mounting the rails also.
Loads		See load and moment rating tables on page 6 for respective load, moment and weight data per size and series.
Acceleration and Deceleration	m/s ² (ft/sec ²)	40 m/s ² maximum (131 ft/s ² maximum)
Guide installation		Possible in any position. See technical information on page 10 for specific instructions on installing various guide configurations.
Drag adjustment set screw		Cassettes can be adjusted at the factory or by the customer. Rollershoes can be set-up by the customer to incorporate the drag adjustment set screw feature. The drag adjustment set screw components are supplied with each pair of rollershoes.
Coefficient of friction		Variable, but .001 set at standard slide resistance adjustment.
Standard Lubrication		Lifetime lubrication with standard grease-packed roller bearings.
Speed	m/s (ft/s)	Up to 10 m/s (or up to 33 ft/s)
Materials for High Performance or Standard versions		Rail: Aluminum alloy
		Guideways: Hardened high alloy spring steel
		Cassettes/rollershoes/top plates: Aluminum alloy
		Rollers: Bearing steel
Materials for Corrosion Resistant High Performance & Standard versions		Rail: Aluminum alloy
		Guideways: Stainless steel spring steel
		Cassettes/rollershoes/top plates: Aluminum alloy
		Rollers: Stainless steel bearing steel
Bearing types		Steel axial needle, Specials on request (ex: anti-magnetic, grease free, high dynamics) - consult factory
Operating temperature	C (F)	-10° to 80°C (+14 to 176°F) temperature range
Specials available		Custom length cassettes and rollershoes for 100 piece lots minimum.
		Keyed butt-jointed rail sections for continuous rail lengths over 4000mm.
		Solid continuous length rails between 4000.
		Offset or non-standard "L11" dimensions on opposite ends of cut rails.
		Integrated metal scraper with standard full profile wiper currently available.
		Rail underside blind mounting holes.

Descriptions of the Various GDL Series Available:

High Performance Series:

(Sizes FDC12HP-... thru FDC45HP-...)

The High Performance series is the basis for GDL's development, which is used in the majority of applications. High Performance guides consist of 8 axial needle roller bearings, running on precision polished and hardened alloy spring steel guideways. These guide bearings are grease packed and shielded, while offering the highest load and moment rating capacities within the GDL product line.

Standard Performance Series:

(Sizes FDC12SP-... thru FDC45SP-...)

The Standard Performance series is intended for minor loads and moments for particularly economical guidance solutions. Standard Performance guides consist of 8 radial ball roller bearings, running on precision polished and hardened alloy spring steel guideways. These guide bearings are grease packed and sealed, while offering the lowest load and moment ratings available within the GDL product line, with the exception of the Grease-Free and the Anti-Friction / Corrosion Resistant series. Standard Performance series is the second most commonly used GDL guides for various applications and also provides excellent running behavior.

General Facts Pertaining to all Series:

Snap-on full profile wipers: Rollershoes and cassettes can be provided with snap-on full profile wipers. The snap-on full profile wipers are easily replaceable with available wiper kits. See page C14 for respective wiper kit order numbers.

Cassette adjustment: Cassettes can be adjusted at the factory or by the customer.

Fasteners: Rollershoes and cassettes use ISO screw quality 8.8 and DIN 433 washers. ISO screw quality 8.8 is recommended for mounting the rails also. Special stainless steel fasteners can be requested as necessary.

Carrying Capacity: See load and moment rating tables on page C6 for your guide series of interest.

Guide mounting position: Optional.

Lengths: For longer than standard rail lengths, see keyed butt-jointed rail option on page C8.

Lubrication: GDL Aluminum Roller Guides are permanently lubricated with contained roller bearings grease.

See part numbering schemes on pages C14 to define your desired GDL guide features for ordering.

Drawing for Cassette with Double Sided Rail

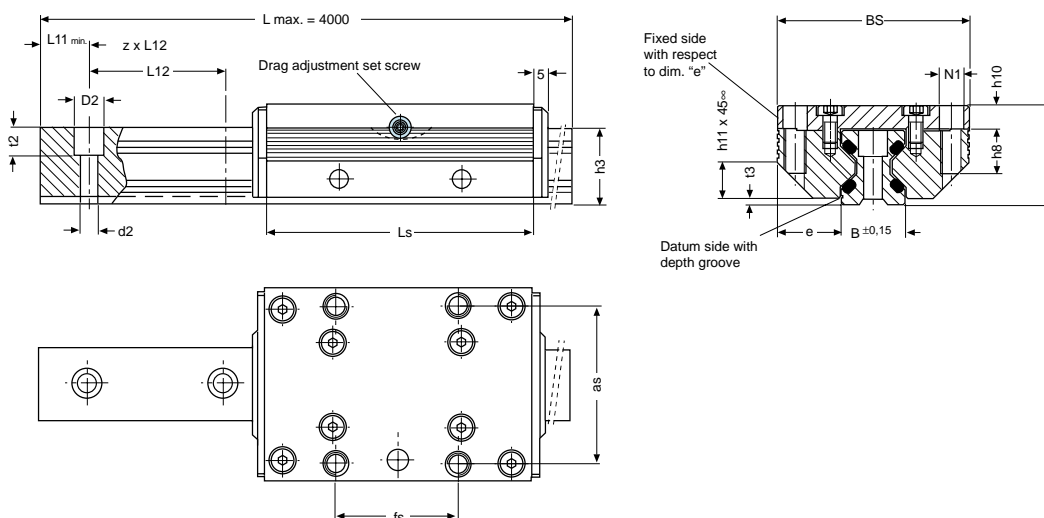

Dimensions for both Standard FDC Version Guides

Size	Length Ls	Width BE	B	BS	B1	Height B2	h1	h3	h9	as	d2	D2	e	fs	h7	h8	h10	h11	L8	L9	L11 min.	L12	t2	t3	N1	N2	N3	PF1	PF2	S1	S2	S3
12	64	12.00	12.0	37	24.4	11.9	15.0	14.7	19	30	3.4	6	12.50	25	6.0	8	4.0	6	29	57	10	40	5.5	1.4	M4	M3	M4	5.5	3.4	3.4	4.9	9.7
15	78	15.25	15.5	47	30.9	15.2	19.0	18.7	24	38	4.5	8	15.75	30	7.5	10	5.0	8	34	68	10	60	6.0	2.0	M5	M4	M6	7.0	4.4	4.9	5.9	12.4
20	92	20.00	21.0	63	40.9	20.4	23.0	22.6	30	53	5.5	10	21.00	40	8.0	12	7.0	11	42	80	10	60	7.0	2.0	M6	M5	M6	9.5	4.9	5.9	5.9	16.9
25	98	25.00	23.0	70	48.4	22.9	27.5	27.0	36	57	6.6	11	23.50	45	5.0	16	8.5	13	48	84	10	60	10.0	2.5	M8	M5	M8	12.0	6.4	7.4	8.9	19.4
35	135	35.00	32.0	100	68.9	32.9	37.5	37.0	48	82	9.0	15	34.00	62	7.5	20	10.5	20	67	117	12	80	11.5	3.5	M10	M6	M8	17.0	8.9	8.9	8.9	28.4
45	165	45.00	45.0	120	82.4	36.4	46.5	46.0	60	100	11.0	18	37.50	80	9.5	24	13.5	22	83	146	16	105	14.5	4.0	M12	M8	M8	22.0	9.9	9.9	8.9	30.9

Dimensions (mm)

Dimensions for both Underside Mounting Hole FDC Version Guides (Ref. ordering instructions)

Size	Length Ls	Width BE	B	BS	B1	Height B2	h1	h3	h9	as	d2	D2	e	fs	h7	h8	h10	h11	L8	L9	L11 min.	L12	t2	t3	N1	N2	N3	PF1	PF2	S1	S2	S3
12	64	12.00	12.0	37	24.4	11.9	15.0	14.7	19	30	3.4	6	12.50	29	6.0	8	4.0	6	29	57	10	40	5.5	1.4	M4	M3	M4	5.5	3.4	3.4	4.9	9.7
15	78	15.25	15.5	47	30.9	15.2	19.0	18.7	24	38	4.5	8	15.75	34	7.5	10	5.0	8	34	68	10	60	6.0	2.0	M5	M4	M6	7.0	4.4	4.9	5.9	12.4
20	92	20.00	21.0	63	40.9	20.4	23.0	22.6	30	53	5.5	10	21.00	40	8.0	12	7.0	11	42	80	10	60	7.0	2.0	M6	M5	M6	9.5	4.9	5.9	5.9	16.9
25	98	25.00	23.0	70	48.4	22.9	27.5	27.0	36	57	6.6	11	23.50	45	5.0	16	8.5	13	48	84	10	60	10.0	2.5	M8	M5	M8	12.0	6.4	7.4	8.9	19.4
35	135	35.00	32.0	100	68.9	32.9	37.5	37.0	48	82	9.0	15	34.00	62	7.5	20	10.5	20	67	117	12	80	11.5	3.5	M10	M6	M8	17.0	8.9	8.9	8.9	28.4
45	165	45.00	45.0	120	82.4	36.4	46.5	46.0	60	100	11.0	18	37.50	90	9.5	24	13.5	22	83	146	16	105	14.5	4.0	M12	M8	M8	22.0	9.9	9.9	8.9	30.9

Dimensions (mm)



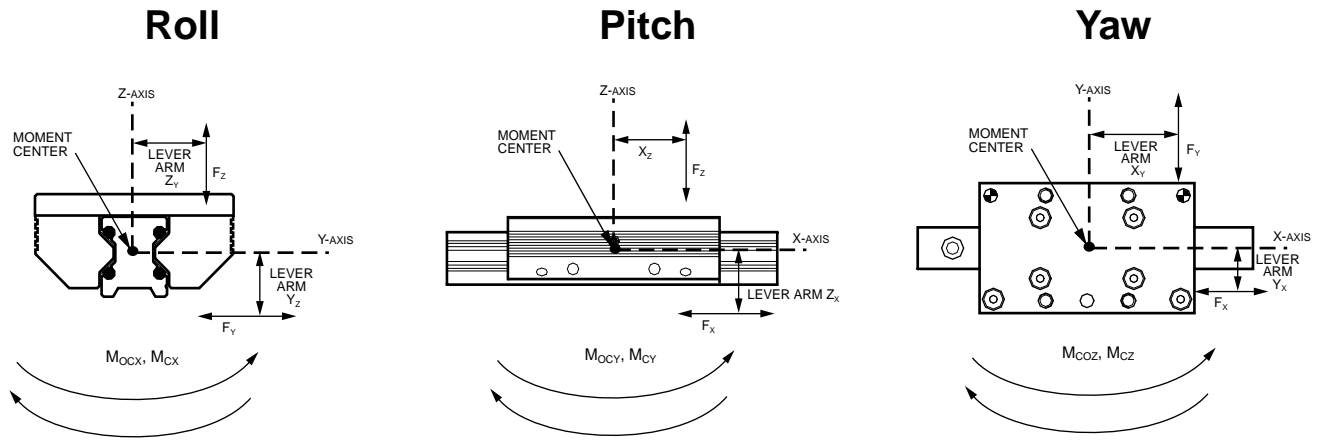

Load & Moment Rating Capacities
 (for cassettes on double sided rail)

Cassette Series	Dynamic Load Rating C (N)	Static Load Rating Co (N)	Static Moment Rating Capacities:			Dynamic Moment Rating Capacities:			Cassette Weight (kg)	Rail Weight (kg)
			Roll Mox (Nm)	Pitch Mocy (Nm)	Yaw Mocz (Nm)	Roll Mcx (Nm)	Pitch Mcy (Nm)	Yaw Mcz (Nm)		
High Performance Series										
FDC12HP-...	2800	3000	27	43	43	25	40	40	0.1	0.4
FDC15HP-...	4200	3400	37	58	58	45	72	72	0.3	0.8
FDC20HP-...	5400	5400	76	111	111	76	111	111	0.4	0.9
FDC25HP-...	9000	10100	158	222	222	142	198	198	0.6	1.8
FDC35HP-...	12500	18000	423	559	559	294	388	388	1.5	3.2
FDC45HP-...	21200	25900	827	983	983	678	806	806	2.9	5.5

C

GDL Aluminum Roller Guides

*High Performance cassettes
 with lock device*

Special cassette types

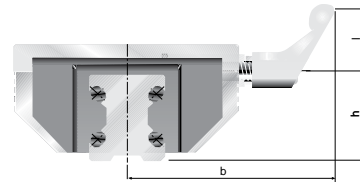
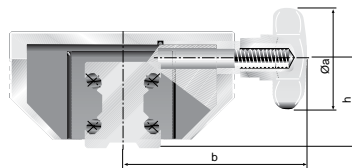

The locking cassette with star grip handle can be stopped at any desired location on the rail. The clamping device does not exert forces on the rail guideways.

The clamping device is used in fixtures which are movable manually, clamping and stop ledgers, feeding of tools and work pieces. Also available with L-ratchet handle.

Star Grip Handle Dimensions

Size	Ø a	b	h	Clamp Force	Part Numbers Star grip knob
12	N/A				
15	25	41	19.0	200	FDC15HP-00020000
20	25	49	23.0	250	FDC20HP-00020000
25	32	56	28.0	250	FDC25HP-00020000
35	50	83	38.5	350	FDC35HP-00020000
45	63	101	48.0	750	FDC45HP-00020000

Dimensions (mm), Force (N) with normal manual tightening.

L-Ratchet Handle Dimensions

Size	l	b	h	Clamp Force	Part Numbers L-ratchet handle
12	N/A				
15	45	59.5	19.0	200	FDC15HP-00010000
20	45	67.5	23.0	250	FDC20HP-00010000
25	45	71	28.0	250	FDC25HP-00010000
35	63	96	38.5	350	FDC35HP-00010000
45	78	116	48.0	750	FDC45HP-00010000

End of Stroke Stop screws

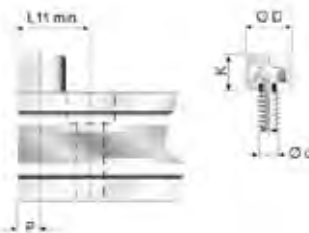

The stop screws are screwed into threads (option) on the guide rails. The end of stroke stopping energy is reduced by a rubber cap. With guide rails where the L11 is less than the standard minimum, we offset the mounting hole by half of its diameter.

Note: Customer must drill and tap the holes for the stop screws.

Size	d	D	K	L11 min.	P	Order Number
12	M5	12	8	15.0	6.0	63504A
15	M5	12	8	16.0	6.0	63504A
20	M5	12	8	17.0	6.0	63504A
25	M6	15	10	20.5	7.5	63505A
35	M8	19	13	26.5	9.5	63506A
45	M10	24	16	33.0	12.0	63507A

Dimensions (mm)

GDL Accessories

Rail Mounting Screw Covers



Material: Wear resistant plastic, resistant to oil and aging.
Mounting: Put a plastic plate on top and pound in uniformly. Remove residual burrs with a soft brush or fingernail.

Note: Use respective order numbers for ordering separately or include in rail part number.

Size	Cylindrical Screw DIN912	D	Order Number
12	M3	6	87752A
15	M4	8	87753A
20	M5	10	87754A
25	M6	11	87755A
35	M8	15	87756A
45	M10	18	87757A

Dimensions (mm)



GDL Aluminum Roller Guides

Version with wipers

Integrated into an additional cover, a felt wiper is saturated with oil. Although dependent on the degree of contaminants, these wipers last for some 6000km, after which the

felt wipers can either be washed or replaced.

For optimal cassette rolling performance, all holes in the guide rails should be filled with the plastic rail mounting screw covers (see page C7).

Order numbers for replacement wiper kits

FDC Series and Size	Respective Order Number
12	84457B
15	84480B
20	84481B
25	84482B
35	84483B
45	84484B

*wiper kits are sold in pairs

NOTE: Use respective order numbers for ordering separately as replacements, or specify in cassette part number. See cassette part numbering on pages C14.

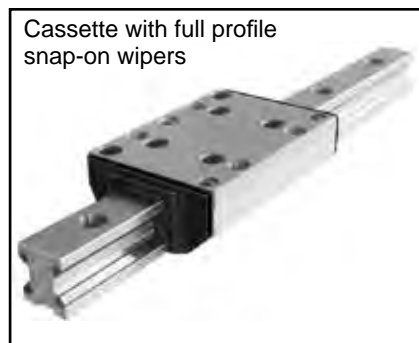

Cassette with full profile snap-on wipers

Full profile snap-on wiper

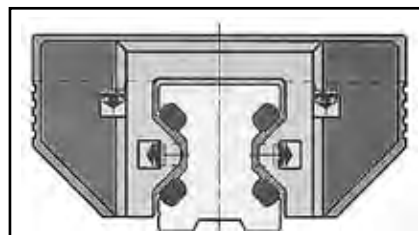

GDL Coupled with structural aluminum extrusion material and OSP-E actuator

C

GDL's Keyed Butt-Jointed Rail Option

GUIDELINE rails can be precisely fastened together using a factory offered keyed butt-joint option for continuous rail lengths, as shown in Figures 1 & 2.

Two rail sections are clamped together with mating round bar stock pieces that seat tangent to both rail section guideways on each side of the rail. While the rail sections are clamped together, a keyway slot is machined in the top and bottom sides of the rail, across the butt-joint. Screw holes are then drilled through the rail inside the keyway slot, so the opposing keyways can be drawn together tightly with screws. The round bar stock clamp is then removed, providing a rigid and well aligned keyed butt-joint.

The keyed butt-joint option provides optimum alignment of all guideways from one rail section to the next. This allows for optimum "smooth" guidance of the cassette bearings, while crossing rail butt-joints.

The keyed butt-jointed rail option is currently available in the FDR version 25, 35, & 45 mm rail sizes. For a keyed butt-joint on rail sizes 25, 35 or 45 mm, specify P/N:# GDL-BJK

Consult factory for other size possibilities.



Figure 1



Figure 2

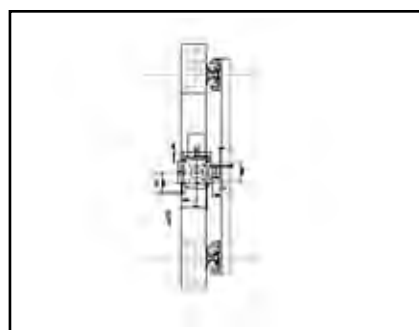

Figure 3

GDL linear guides couple well with various structural aluminum extrusions and Parker-Origa OSP-P and OSP-E actuators. Mounting can be easily accomplished using standard fasteners and mounting brackets. See Figure 3 above.

Units Conversion Tables

Force Conversions:

Multiply	By Conversion Factor	Result
pound-force	4.448	Newton
Newton	0.225	pound-force
kilogram-force	9.807	Newton
Newton	0.102	kilogram-force

Acceleration Conversions:

Multiply	By Conversion Factor	Result
feet/section ²	0.305	meter/second ²
meter/second ²	3.281	feet/second ²
inch/second ²	0.025	meter/second ²
meter/second ²	39.370	inch/second ²

Mass Conversions:

Multiply	By Conversion Factor	Result
ounce	28.349	gram
gram	0.035	ounce
kilogram	35.279	ounce
gram	0.001	kilogram
pound	0.453	kilogram
kilogram	2.205	pound

Bending Moment or Torque Conversions:

Multiply	By Conversion Factor	Result
pound-foot	1.356	Newton-meter
Newton-meter	0.737	pound-foot
Newton-meter	0.102	kilogram-meter
Kilogram-meter	9.807	Newton-meter

Velocity conversions:

Multiply	By Conversion Factor	Result
mile/hour	1.609	kilometer/hour
kilometer/hour	0.621	mile/hour
feet/second	0.305	meter/second
meter/second	3.281	feet/second
inch/minute	0.025	meter/minute
meter/minute	39.370	inch/minute

Length conversions:

Multiply	By Conversion Factor	Result
inch	25.4	millimeter
millimeter	0.039	inch
inch	0.025	meter
meter	39.370	inch
foot	0.305	meter
meter	3.281	foot



1. Features of the Guide System

Aluminum roller guides consist of a double sided rail and a roller cassette or two single sided rails and two roller shoes. Aluminum roller guide rails and cassettes are made of aluminum alloy. The rollers are very smooth running on precision polished guideways made of high alloy spring steel. The special cross pattern orientation of the running rollers provides high load and moment capacity in all directions. Their special features are: light weight, small dimensions, and high speed of displacement. Aluminum roller guides are economical and universal handling components, which are mostly or all corrosion-resistant and available at a favorable price.

2. Size of the Guide System

To select the right guide size, first the moments and forces acting on the bearing have to be determined.

Recommended safety factors (with ISO screws quality 8.8):

- Thrust load S > 1.3
- Tensile load S > 4.0
- Moment load S > 6.0

3. Material

The basic body of GDL aluminum roller guides is made of aluminum alloy. The guideways consist of hardened, high alloy spring steel or of stainless steel. By using basic bodies of aluminum, the moved masses are reduced which allows light-weight construction requiring lower moving forces and reduced energy consumption. Still the integrated GDL system sustains high load and moment ratings.

4. Operating Temperature

GDL linear guides can be operated within a temperature range from -10° C up to + 80° C. For other temperatures, please consult factory.

5. Screwed Connections

GDL linear guides are fixed to the mating structure by the mounting holes in the rails and the cassettes. ISO screw quality 8.8 should be used with DIN 433 washers.

To secure the screwed connections, we recommend that suitable locking means be utilized as necessary.

Mounting screw torque specifications:

	Quality 8.8 (Nm)
M3	1.1
M4	2.5
M5	5.0
M6	8.5
M8	21.0
M10	41.0
M12	71.0

6. Wipers

The guideways of aluminum roller guides are equipped with wipers to protect against coarse environmental contamination.

7. Slide Resistance / Adjustment

Follow the steps on how to adjust GDL cassettes to the rail.

The new GDL catalog has many changes due to an expanded product line. The change to feature descriptive part numbering was done to accommodate all current and future offerings of the GDL product. The goal is to have standard features and options available, for a perfect fit into your application.

Included in the chart below are hex sizes, drag resistance and torque ratings for adjusting the cassette.

GDL CHART						
	FDC 12	FDC 15	FDC 20	FDC 25	FDC 35	FDC 45
Top plate hex (mm)	2	3	4	4	5	6
Top plate torque (in lbs)	n/a	22.1	44.3	44.3	75.2	186
Adjustment hex (mm)	1	3	3	4	4	4
Drag resistance (oz) HP, HC, GF, VA	1.8- 7.9	3.6- 10.8	5.4- 16.2	7.2- 21.6	10.8- 32.4	12.6- 37.7
Drag resistance (oz) SP & SC	.7- 1.8	1.8- 3.6	3.6- 7.2	5.4- 10.8	7.2- 14.4	9- 18
Drag resistance (oz) HD	n/a	n/a	n/a	9- 18	14.4 25	18- 28.7

7.1 GDL Adjustment Procedure

Do not measure sliding resistance with wipers on.

- 1) Lay the rail out on the flat surface with the **datum** line facing away from you. Anchor the rail to keep it from shifting when sliding resistance is applied to the cassette.

The datum line is a reference groove on one side of the rail.

- 2) Set the roller cassette on the rail with the adjustment screw facing towards you, while the datum line on the rail is away from you. Do not install the wipers on the cassette yet.

Do not install the wipers yet.

- 3) Make sure the four bolts on the adjustable side of the cassette are slightly loose and the bolts on the fixed side are tight before adjusting the drag screw.

One side of the cassette is fixed and the other side is floating.

- 4) The drag hex screw is located on one side of the cassette. Adjust the screw in for more drag and out for less. Do not try to adjust cassette with top plates bolts tight.

See the chart for drag adjustment hex screw size.

- 5) Adjust the drag on the cassette by sliding as it slides down the rail. Feel for an even amount of resistance as you turn the hex screw in and out.
- 6) Tighten down the top plate bolts to the proper torque specification. The tightening of the top plate bolts will add some resistance. If necessary, the adjustment procedure can be repeated for better sliding resistance for your application.

See the chart for top plate hex size and torque rating.

- 7) If the adjustment is done without a scale, it should move evenly. Some examples of improper adjustment are: If the



cassette “hops”, it is too tight. If it is too loose, the top plate of the cassette will have play. Try to be in the middle.

- 8) To check your settings use a pull or push style scale. Slide the cassette down the entire rail at an even speed, measuring the drag resistance. Your highest drag rating should be referenced when looking at the chart.

See the chart for drag resistance ratings for the size and type of cassette.

- 9) Install the clip on wipers. The wipers will add between 1-3 ounces of resistance. The wipers do not add any additional roller preload to the rail.

The clip on wipers can be installed at this time.

7.2 Double Sided Rail and Cassette

Aluminum roller guides are adjusted in such a way that the required stiffness under load is obtained. If self adjustment is preferred, we recommend that you measure the slide resistance as shown below. Before doing so, the mating structure should be checked for dimensional accuracy and flatness.

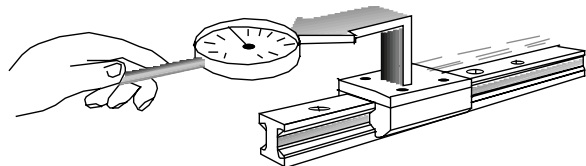

The cassettes which are mounted on the rails are adjusted clearance-free, without play. This adjusting method is required at the point on the rail where the cassette travels with the least slide resistance. Adjustment is completed in the non-loaded condition. The tolerances below refer to this condition.

Slide resistance adjustment tolerance (N)															
Series	FDC_HP, FDC_HC, FDC_AM, FDC_GF, FDC_VA						FDC_SP, FDC_SC						FDC_HD		
Size	12	15	20	25	35	45	12	15	20	25	35	45	25	35	45
Adjust. value	0.5	1.0	1.5	2.0	3.0	3.5	0.2	0.5	1.0	1.5	2.0	2.5	2.5	4.0	5.0
Max. value	2.0	3.0	4.5	6.0	9.0	10.5	0.5	1.0	2.0	3.0	4.0	5.0	5.0	7.0	8.0

All values are without wipers

Tolerances in the guide system may cause slight variations in the slide resistance, when the adjusted cassette is moved along the guide rail.

7.3 Double Sided Rail and Roller Cassette

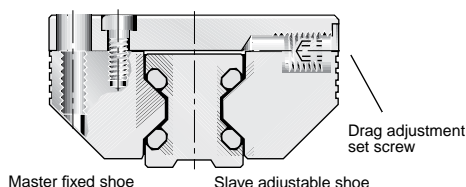

To change the clearance setting, first the slave adjustable shoe screws on the cassette top plate are slightly loosened. Afterwards, the drag adjustment set screw is turned to increase or decrease slide resistance of the cassette. Turning the drag adjustment set screw effects a displacement of the roller shoe in relation to the cassette top plate.

After re-tightening of the cassette top plate, the slide resistance can be checked. This procedure can be repeated until the desired slide resistance is achieved.

7.4 Rails and Rollershoes

When installing, it is important to distinguish between the master fixed side and the slave adjustable side rollershoe and rail. The rail on the master fixed side is aligned to the mating structure and fastened securely by all screws.

The rail on the slave adjustable side should be lightly tightened and movable with light force during initial alignment of parallel rails. Gauge blocks should be used between the parallel rails, by locating off the aligned and mounted master rail, in order to align the slave rail parallel to the master rail. Slave rail mounting bolts should be tightened as the slave rail is aligned at each bolt position. See paragraph 11.3 for further instructions on mounting parallel single sided rails.

7.5 Centering Groove on the Master Fixed Shoe and Custom Top Plate

Each pair of rollershoes are provided with centering grooves for optimum alignment to their mating top plate during mounting.

One rollershoe should be designated as the master fixed rollershoe, even though both are designed with a centering groove on their top surface. The other shoe will serve as the slave adjustable side rollershoe. The mating customized top plate should be machined with a centering shoulder according to the following data.

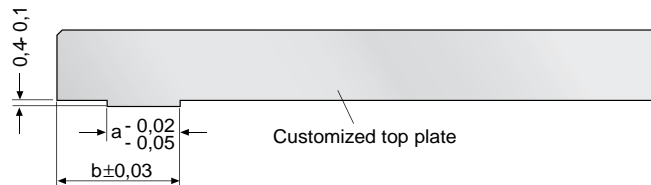

Size	a	b
12	4,5	9,6
15	5,0	12,6
20	7,5	16,1
25	10,5	17,6
35	12,5	26,1



7.6 Adjusting Cassette Built with Rollershoes and Custom Top Plate

The centering shoulder on the top plate should be assembled with its respective fixed rollershoe centering groove and securely torqued to recommended specification. See cassette screw torque specifications under step 5, on page C10.

Assemble the adjustable rollershoe to the top plate also, parallel to the fixed rollershoe on the same side of the top plate. Its fasteners should be lightly tightened so that the adjustable rollershoe can be moved with light finger pressure.

As assembled cassette can then be slid onto parallel rails, while keeping the fixed rollershoe on the master fixed rail side. The incorporated drag adjustment set screw can then be turned clockwise to remove cassette play, or counter clockwise to reduce slide resistance while maintaining zero play.

Once the desired slide resistance is achieved with no cassette play, the adjustable rollershoe fasteners can also be torqued to specification.

8. Running accuracy

The running accuracy is measured from the top plate surface of the cassette, to the ideal straight line of travel. Running accuracy of the cassette to the rail is $\pm .03\text{mm}$ (.0012") per meter, granted no greater than (.0024") straightness deviation per meter is maintained when mounting the rail.

9. Contact and support surfaces

The contact and support surfaces have a substantial influence on functioning and precision of linear guides. Depending on the functional requirements of the system, the mating structure has to be machined with the corresponding degree of precision.

Machining errors on the mating structure will otherwise add to the running error of the guide system. In order to assure troublefree functioning, we recommend that a max. straightness deviation of $\leq 0.1\text{ mm}$ (.0039") per running meter be maintained when mounting the rail.

10. Design hints

10.1 Parallel double sided rails and cassettes



The master fixed rail should always be established straight and true first, within the maximum straightness deviation specified in paragraph 9. With parallel rail arrangements, both rails should be mounted on the same mounting surface elevation and treated with equal surface preparation and

tolerancing practices. Precise alignment in terms of spacing, parallelism and height is very important.

When coupled parallel to a driving actuator system, the adjustable side of the cassette should be placed on the side closest to the driving actuator. This will minimize driving actuator torque transferred to the adjustable side of the cassette.

11. Guide mounting instructions

The useable load capacity is influenced by the connection between the guide elements and the mating structure. For this reason, a flat, straight and solid secure mounting surface should be provided. Adequate support of qualified loads and moments can then be achieved, along with desired running accuracy.

11.1 Mounting Double Sided Rails and Cassette

Depending on the load situation, certain double sided rails should either be screwed or screwed and dowelled, and respectively put into grooves or against a shoulder.

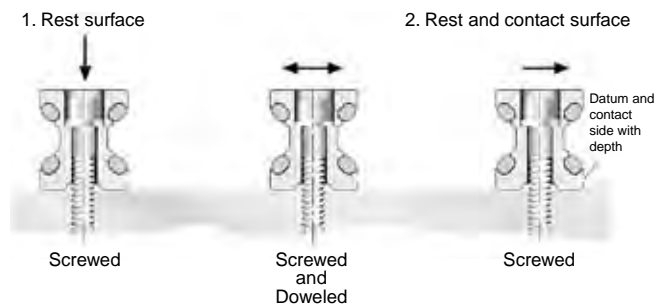

The rails can be secured best against shoulders and are screwed or screwed and dowelled to the mating structure. After final adjustment of rail straightness and parallelism, the rail mounting screws are tightened starting in the middle of the rail length. Rail mounting bolts should be torqued to specification by alternating between each bolt. The installer should start with the bolt in the center of the rail length and proceed by alternating between each bolt left of center and each bolt right of center, while working towards both ends of the rail.

Afterwards, the cassette should be moved back and forth along the total stroke distance of the rail. If the cassette travels smoothly, the mounting process can proceed or be completed.

11.2 Mounting Parallel Double Sided Rails and Cassettes

With parallel double sided rail arrangements, we recommend that the master fixed rail side and slave adjustment rail sides of the guide system be identified. This allows optimum tolerances in parallelism to be achieved best by adjusting the slave adjustable rail, parallel to the master rail. The master fixed rail side should be mounted first to achieve the initial line of straight travel.

The example below displays a convenient method for adjusting the slave adjustable rail parallel to the fixed master rail. Once the cassette travel is smooth, without play, one can proceed with rail mounting.

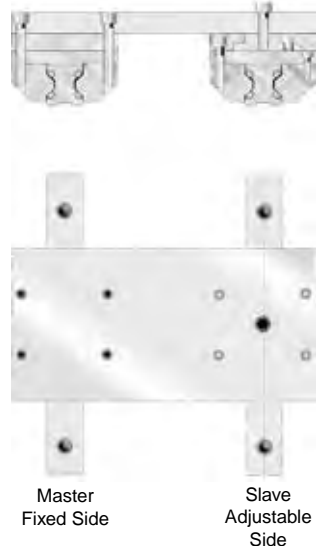

Note that the top plate spanning across the cassettes on opposite rails is completely bolted down to the cassette on the master fixed side only. The top plate end over the slave adjustable side is only bolted in one location, in the center of the slave adjustment side cassette. With one bolt holding the top plate to the slave adjustment side cassette, this cassette can pivot while the slave adjustable rail self-aligns parallel to the fixed master rail side. The floating top plate setup is stroked along the entire rail length, to establish the parallelism between the two rails.

Calibrated gauge blocks can also be used to establish equal integrity in rail parallelism. The installer should seat and temporarily clamp short pieces of precision ground round stock, tangent to the two guideways on the inside of each rail.

Rail Size	Precision Round Stock Sizes Ø mm
12	11
15	11
20	14
25	16
35	27
45	35

The calibrated gauge blocks can then be used, to locate off the precision round stock on the master fixed rail, in order to set the slave adjustable rail parallel. The gauge blocks are then locating the same way that the floating top plate is, by referencing both the master and slave rail guideway surfaces to establish parallelism.

Once the slave adjustable rail has been self-aligned, its bolts should also be torqued to specification in the order mentioned in paragraph 11.1. The top spanning across both cassettes on opposite rails, can then be securely fastened using all cassette mounting bolt holes.

12. Keyed Butt-jointing of Rail Sections

12.1 Rail Hole Spacing

Butt-jointed rails over L = 4000 mm are sectioned together according to the GDL standard. See “GDL’s Keyed Butt-Jointed Rail Option” on page C8. Butt-jointed rails sections are cut so that the standard rail mounting hole spacing is maintained across all butt-joints.

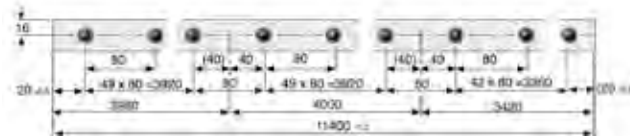

Keyed butt-jointed rails are usually shipped completely assembled, but sometimes must be shipped partially assembled, due to shipping length limitations and shipping care. Partially assembled butt-jointed rails are supplied with a butt-jointing clamping fixture and the keyways and screws for fastening rail section together.

12.2 Mounting of butt-jointed rails

Clean mounting surfaces, then place rail sections loose on the guide path, one behind the other. Lay the rails in their correct sequence of the system design (i.e.: 1, 2, 3, 4...etc.). The orientation of the depth groove on the lower surface of the rail should always be on the same side for all rail sections being butt-jointed.

Any non-assembled rail sections should be aligned with the factory supplied butt-joint clamping fixture as displayed below.



See explanation of “GDL’s Keyed Butt-Jointed Rail Option” on page C8.

Once all rail sections are assembled, the complete guide path can be aligned and fastened. Alignment and fastening should be conducted according to the applicable guide arrangement and steps previously described in this technical information section.



Ordering Instructions / Part Numbering System for GDL Rails

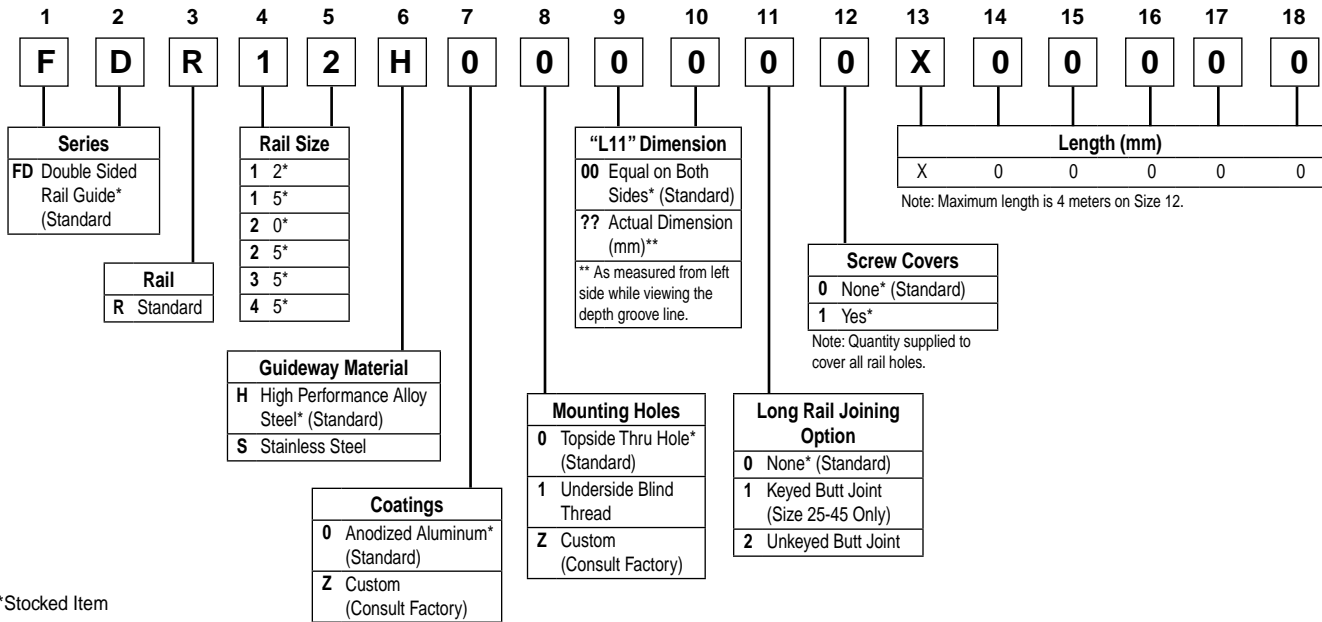

*Stocked Item

Ordering Instructions / Part Numbering System for GDL Cassettes

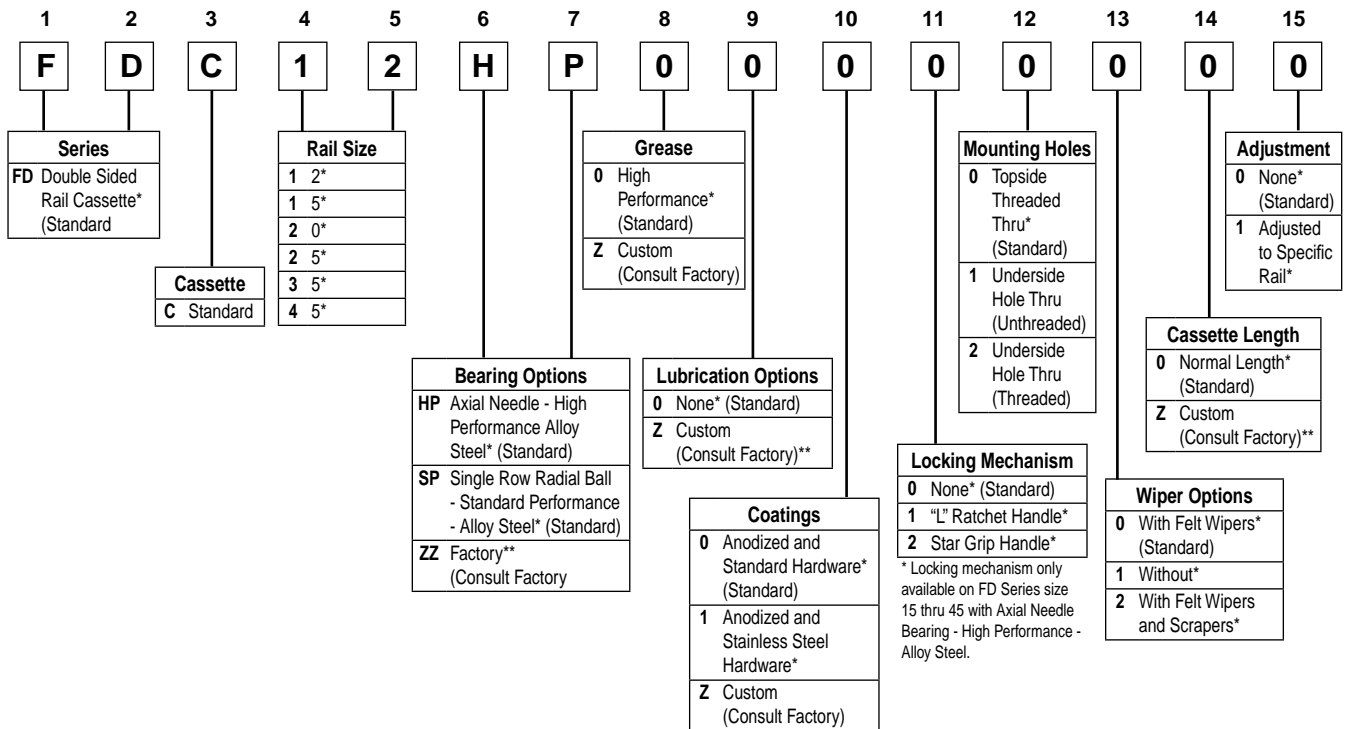

*Stocked Item

**Minimum Order Quantity Required

Application Sheet

GDL Application Sheet

Distributor: _____ End-User: _____

Salesperson: _____

Phone: _____ Fax: _____ e-mail: _____

Other Information: _____

Roll

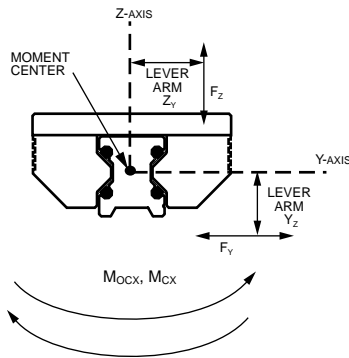

Roll load _____

X - Distance _____

Y - Distance _____

Z - Distance _____

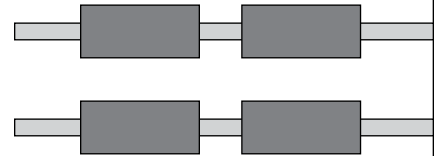

Length of rails _____

Distance between rails _____

Distance between cassettes on each rail _____

Pitch

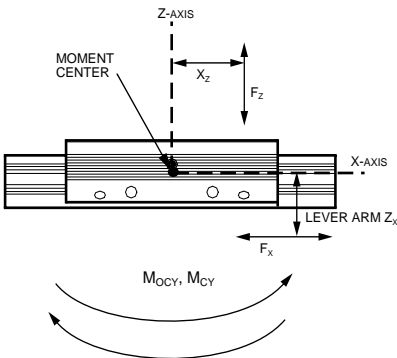

Pitch load _____

X - Distance _____

Y - Distance _____

Z - Distance _____

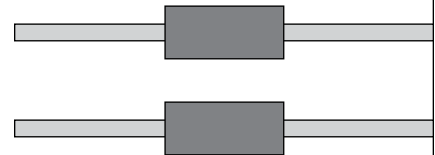

Technical Data:

Stroke _____

Horizontal _____

Vertical _____

Velocity / Speed _____

Acceleration _____

Load / Mass _____

Load Distances _____

Lifetime Desired _____

Environment:
(Dirt, Humidity...)

Yaw

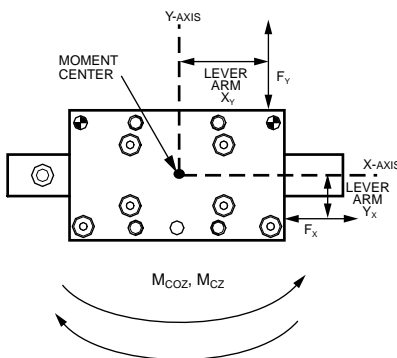

Yaw load _____

X - Distance _____

Y - Distance _____

Z - Distance _____



Safety Guide

Safety Guide for Selecting and Using Hydraulic, Pneumatic Cylinders and Their Accessories

WARNING: ⚠ FAILURE OF THE CYLINDER, ITS PARTS, ITS MOUNTING, ITS CONNECTIONS TO OTHER OBJECTS, OR ITS CONTROLS CAN RESULT IN:

- Unanticipated or uncontrolled movement of the cylinder or objects connected to it.
- Falling of the cylinder or objects held up by it.
- Fluid escaping from the cylinder, potentially at high velocity.

THESE EVENTS COULD CAUSE DEATH OR PERSONAL INJURY BY, FOR EXAMPLE, PERSONS FALLING FROM HIGH LOCATIONS, BEING CRUSHED OR STRUCK BY HEAVY OR FAST MOVING OBJECTS, BEING PUSHED INTO DANGEROUS EQUIPMENT OR SITUATIONS, OR SLIPPING ON ESCAPED FLUID.

Before selecting or using Parker (The Company) cylinders or related accessories, it is important that you read, understand and follow the following safety information. Training is advised before selecting and using The Company's products.

1.0 General Instructions

1.1 Scope – This safety guide provides instructions for selecting and using (including assembling, installing, and maintaining) cylinder products. This safety guide is a supplement to and is to be used with the specific Company publications for the specific cylinder products that are being considered for use.

1.2 Fail Safe – Cylinder products can and do fail without warning for many reasons. All systems and equipment should be designed in a fail-safe mode so that if the failure of a cylinder product occurs people and property won't be endangered.

1.3 Distribution – Provide a free copy of this safety guide to each person responsible for selecting or using cylinder products. Do not select or use The Company's cylinders without thoroughly reading and understanding this safety guide as well as the specific Company publications for the products considered or selected.

1.4 User Responsibility – Due to very wide variety of cylinder applications and cylinder operating conditions, The Company does not warrant that any particular cylinder is suitable for any specific application. This safety guide does not analyze all technical parameters that must be considered in selecting a product. The hydraulic and pneumatic cylinders outlined in this catalog are designed to The Company's design guidelines and do not necessarily meet the design guideline of other agencies such as American Bureau of Shipping, ASME Pressure Vessel Code etc. The user, through its own analysis and testing, is solely responsible for:

- Making the final selection of the cylinders and related accessories.
- Determining if the cylinders are required to meet specific design requirements as required by the Agency(s) or industry standards covering the design of the user's equipment.
- Assuring that the user's requirements are met, OSHA requirements are met, and safety guidelines from the applicable agencies such as but not limited to ANSI are followed and that the use presents no health or safety hazards.
- Providing all appropriate health and safety warnings on the equipment on which the cylinders are used.

1.5 Additional Questions – Call the appropriate Company technical service department if you have any questions or require any additional information. See the Company publication for the product being considered or used, or call 1-800-CPARKER, or go to www.parker.com, for telephone numbers of the appropriate technical service department.

2.0 Cylinder and Accessories Selection

2.1 Seals – Part of the process of selecting a cylinder is the selection of seal compounds. Before making this selection, consult the "seal information page(s)" of the publication for the series of cylinders of interest.

The application of cylinders may allow fluids such as cutting fluids, wash down fluids etc. to come in contact with the external area of the cylinder. These fluids may attack the piston rod wiper and or the primary seal and must be taken into account when selecting and specifying seal compounds.

Dynamic seals will wear. The rate of wear will depend on many operating factors. Wear can be rapid if a cylinder is misaligned or if the cylinder has been improperly serviced. The user must take seal wear into consideration in the application of cylinders.

2.2 Piston Rods – Possible consequences of piston rod failure or separation of the piston rod from the piston include, but are not limited to are:

- Piston rod and or attached load thrown off at high speed.
- High velocity fluid discharge.
- Piston rod extending when pressure is applied in the piston retract mode.

Piston rods or machine members attached to the piston rod may move suddenly and without warning as a consequence of other conditions occurring to the machine such as, but not limited to:

- Unexpected detachment of the machine member from the piston rod.
- Failure of the pressurized fluid delivery system (hoses, fittings, valves, pumps, compressors) which maintain cylinder position.
- Catastrophic cylinder seal failure leading to sudden loss of pressurized fluid.
- Failure of the machine control system.

Follow the recommendations of the "Piston Rod Selection Chart and Data" in the publication for the series of cylinders of interest. The suggested piston rod diameter in these charts must be followed in order to avoid piston rod buckling.

Piston rods are not normally designed to absorb bending moments or loads which are perpendicular to the axis of piston rod motion. These additional loads can cause the piston rod to fail. If these types of additional loads are expected to be imposed on the piston rod, their magnitude should be made known to our engineering department.

The cylinder user should always make sure that the piston rod is securely attached to the machine member.

On occasion cylinders are ordered with double rods (a piston rod extended from both ends of the cylinder). In some cases a stop is threaded on to one of the piston rods and used as an external stroke adjuster. On occasions spacers are attached to the machine member connected to the piston rod and also used as a stroke adjuster. In both cases the stops will create a pinch point and the user should consider appropriate use of guards. If these external stops are not perpendicular to the mating contact surface, or if debris is trapped between the contact surfaces, a bending moment will be placed on the piston rod, which can lead to piston rod failure. An external stop will also negate the effect of cushioning and will subject the piston rod to impact loading. Those two (2) conditions can cause piston rod failure. Internal stroke adjusters are available with and without cushions. The use of external stroke adjusters should be reviewed with our engineering department.

The piston rod to piston and the stud to piston rod threaded connections are secured with an anaerobic adhesive. The strength of the adhesive decreases with increasing temperature. Cylinders which can be exposed to temperatures above +250°F (+121°C) are to be ordered with a non studded piston rod and a pinned piston to rod joint.

2.3 Cushions – Cushions should be considered for cylinder applications when the piston velocity is expected to be over 4 inches/second.

Cylinder cushions are normally designed to absorb the energy of a linear applied load. A rotating mass has considerably more energy than the same mass moving in a linear mode. Cushioning for a rotating mass application should be review by our engineering department.

2.4 Cylinder Mountings – Some cylinder mounting configurations may have certain limitations such as but not limited to minimum stroke for side or foot mounting cylinders or pressure de-ratings for certain mounts. Carefully review the catalog for these types of restrictions.

Always mount cylinders using the largest possible high tensile alloy steel socket head cap screws that can fit in the cylinder mounting holes and torque them to the manufacturer's recommendations for their size.

2.5 Port Fittings – Hydraulic cylinders applied with meter out or deceleration circuits are subject to intensified pressure at piston rod end.

The rod end pressure is approximately equal to:

$$\frac{\text{operating pressure} \times \text{effective cap end area}}{\text{effective rod end piston area}}$$

Contact your connector supplier for the pressure rating of individual connectors.

3.0 Cylinder and Accessories Installation and Mounting

3.1 Installation

3.1.1 – Cleanliness is an important consideration, and cylinders are shipped with the ports plugged to protect them from contaminants

D

Safety Guide

entering the ports. These plugs should not be removed until the piping is to be installed. Before making the connection to the cylinder ports, piping should be thoroughly cleaned to remove all chips or burrs which might have resulted from threading or flaring operations.

3.1.2 – Cylinders operating in an environment where air drying materials are present such as fast-drying chemicals, paint, or weld splatter, or other hazardous conditions such as excessive heat, should have shields installed to prevent damage to the piston rod and piston rod seals.

3.1.3 – Proper alignment of the cylinder piston rod and its mating component on the machine should be checked in both the extended and retracted positions. Improper alignment will result in excessive rod gland and/or cylinder bore wear. On fixed mounting cylinders attaching the piston rod while the rod is retracted will help in achieving proper alignment.

3.1.4 – Sometimes it may be necessary to rotate the piston rod in order to thread the piston rod into the machine member. This operation must always be done with zero pressure being applied to either side of the piston. Failure to follow this procedure may result in loosening the piston to rod-threaded connection. In some rare cases the turning of the piston rod may rotate a threaded piston rod gland and loosen it from the cylinder head. Confirm that this condition is not occurring. If it does, re-tighten the piston rod gland firmly against the cylinder head.

For double rod cylinders it is also important that when attaching or detaching the piston rod from the machine member that the torque be applied to the piston rod end of the cylinder that is directly attaching to the machine member with the opposite end unrestrained. If the design of the machine is such that only the rod end of the cylinder opposite to where the rod attaches to the machine member can be rotated, consult the factory for further instructions.

3.2 Mounting Recommendations

3.2.1 – Always mount cylinders using the largest possible high tensile alloy steel socket head screws that can fit in the cylinder mounting holes and torque them to the manufacturer's recommendations for their size.

3.2.2 – Side-Mounted Cylinders – In addition to the mounting bolts, cylinders of this type should be equipped with thrust keys or dowel pins located so as to resist the major load.

3.2.3 – Tie Rod Mounting – Cylinders with tie rod mountings are recommended for applications where mounting space is limited. The standard tie rod extension is shown as BB in dimension tables. Longer or shorter extensions can be supplied. Nuts used for this mounting style should be torqued to the same value as the tie rods for that bore size.

3.2.4 – Flange Mount Cylinders – The controlled diameter of the rod gland extension on head end flange mount cylinders can be used as a pilot to locate the cylinders in relation to the machine. After alignment has been obtained, the flanges may be drilled for pins or dowels to prevent shifting.

3.2.5 – Trunnion Mountings – Cylinders require lubricated bearing blocks with minimum bearing clearances. Bearing blocks should be carefully aligned and rigidly mounted so the trunnions will not be subjected to bending moments. The rod end should also be pivoted with the pivot pin in line and parallel to axis of the trunnion pins.

3.2.6 – Clevis Mountings – Cylinders should be pivoted at both ends with centerline of pins parallel to each other. After cylinder is mounted, be sure to check to assure that the cylinder is free to swing through its working arc without interference from other machine parts.

4.0 Cylinder and Accessories Maintenance, Troubleshooting and Replacement

4.1 Storage – At times cylinders are delivered before a customer is ready to install them and must be stored for a period of time. When storage is required the following procedures are recommended.

4.1.1 – Store the cylinders in an indoor area which has a dry, clean and noncorrosive atmosphere. Take care to protect the cylinder from both internal corrosion and external damage.

4.1.2 – Whenever possible cylinders should be stored in a vertical position (piston rod up). This will minimize corrosion due to possible condensation which could occur inside the cylinder. This will also minimize seal damage.

4.1.3 – Port protector plugs should be left in the cylinder until the time of installation.

4.1.4 – If a cylinder is stored full of hydraulic fluid, expansion of the fluid due to temperature changes must be considered. Installing a check valve with free flow out of the cylinder is one method.

4.1.5 – When cylinders are mounted on equipment that is stored outside for extended periods, exposed unpainted surfaces, e.g. piston rod, must be coated with a rust-inhibiting compound to prevent corrosion.

4.2 Cylinder Trouble Shooting

4.2.1 – External Leakage

4.2.1.1 – Rod seal leakage can generally be traced to worn or damaged seals. Examine the piston rod for dents, gouges or score marks, and replace piston rod if surface is rough.

Rod seal leakage could also be traced to gland wear. If clearance is excessive, replace rod bushing and seal. Rod seal leakage can also be traced to seal deterioration. If seals are soft or gummy or brittle, check compatibility of seal material with lubricant used if air cylinder, or operating fluid if hydraulic cylinder. Replace with seal material, which is compatible with these fluids. If the seals are hard or have lost elasticity, it is usually due to exposure to temperatures in excess of 165°F. (+74°C). Shield the cylinder from the heat source to limit temperature to 350°F. (+177°C.) and replace with fluorocarbon seals.

4.2.1.2 – Cylinder body seal leak can generally be traced to loose tie rods. Torque the tie rods to manufacturer's recommendation for that bore size.

Excessive pressure can also result in cylinder body seal leak. Determine maximum pressure to rated limits. Replace seals and retorqued tie rods as in paragraph above. Excessive pressure can also result in cylinder body seal leak. Determine if the pressure rating of the cylinder has been exceeded. If so, bring the operating pressure down to the rating of the cylinder and have the tie rods replaced.

Pinched or extruded cylinder body seal will also result in a leak. Replace cylinder body seal and retorqued as in paragraph above.

Cylinder body seal leakage due to loss of radial squeeze which shows up in the form of flat spots or due to wear on the O.D. or I.D. – Either of these are symptoms of normal wear due to high cycle rate or length of service. Replace seals as per paragraph above.

4.2.2 – Internal Leakage

4.2.2.1 – Piston seal leak (by-pass) 1 to 3 cubic inches per minute leakage is considered normal for piston ring construction. Virtually no static leak with lipseal type seals on piston should be expected. Piston seal wear is a usual cause of piston seal leakage. Replace seals as required.

4.2.2.2 – With lipseal type piston seals excessive back pressure due to over-adjustment of speed control valves could be a direct cause of rapid seal wear. Contamination in a hydraulic system can result in a scored cylinder bore, resulting in rapid seal wear. In either case, replace piston seals as required.

4.2.2.3 – What appears to be piston seal leak, evidenced by the fact that the cylinder drifts, is not always traceable to the piston. To make sure, it is suggested that one side of the cylinder piston be pressurized and the fluid line at the opposite port be disconnected. Observe leakage. If none is evident, seek the cause of cylinder drift in other component parts in the circuit.

4.2.3 – Cylinder Fails to Move the Load

4.2.3.1 – Pneumatic or hydraulic pressure is too low. Check the pressure at the cylinder to make sure it is to circuit requirements.

4.2.3.2 – Piston Seal Leak – Operate the valve to cycle the cylinder and observe fluid flow at valve exhaust ports at end of cylinder stroke. Replace piston seals if flow is excessive.

4.2.3.3 – Cylinder is undersized for the load – Replace cylinder with one of a larger bore size.

4.3 Erratic or Chatter Operation

4.3.1 – Excessive friction at rod gland or piston bearing due to load misalignment – Correct cylinder-to-load alignment.

4.3.2 – Cylinder sized too close to load requirements – Reduce load or install larger cylinder.

4.3.3 – Erratic operation could be traced to the difference between static and kinetic friction. Install speed control valves to provide a back pressure to control the stroke.

4.4 Cylinder Modifications, Repairs, or Failed Component – Cylinders as shipped from the factory are not to be disassembled and or modified. If cylinders require modifications, these modifications must be done at company locations or by The Company's certified facilities. The Cylinder Division Engineering Department must be notified in the event of a mechanical fracture or permanent deformation of any cylinder component (excluding seals). This includes a broken piston rod, tie rod, mounting accessory or any other cylinder component. The notification should include all operation and application details. This information will be used to provide an engineered repair that will prevent recurrence of the failure.

It is allowed to disassemble cylinders for the purpose of replacing seals or seal assemblies. However, this work must be done by strictly following all the instructions provided with the seal kits.

Offer of Sale

The items described in this document and other documents or descriptions provided by Parker Hannifin Corporation, its subsidiaries and its authorized distributors, are hereby offered for sale at prices to be established by Parker Hannifin Corporation, its subsidiaries and its authorized distributors. This offer and its acceptance by any customer ("Buyer") shall be governed by all of the following Terms and Conditions. Buyer's order for any such item, when communicated to Parker Hannifin Corporation, its subsidiaries or an authorized distributor ("Seller") verbally or in writing, shall constitute acceptance of this offer.

1. Terms and Conditions of Sale: All descriptions, quotations, proposals, offers, acknowledgments, acceptances and sales of Seller's products are subject to and shall be governed exclusively by the terms and conditions stated herein. Buyer's acceptance of any offer to sell is limited to these terms and conditions. Any terms or conditions in addition to, or inconsistent with those stated herein, proposed by Buyer in any acceptance of an offer by Seller, are hereby objected to. No such additional, different or inconsistent terms and conditions shall become part of the contract between Buyer and Seller unless expressly accepted in writing by Seller. Seller's acceptance of any offer to purchase by Buyer is expressly conditional upon Buyer's assent to all the terms and conditions stated herein, including any terms in addition to, or inconsistent with those contained in Buyer's offer. Acceptance of Seller's products shall in all events constitute such assent.

2. Payment: Payment shall be made by Buyer net 30 days from the date of delivery of the items purchased hereunder. Amounts not timely paid shall bear interest at the maximum rate permitted by law for each month or portion thereof that the Buyer is late in making payment. Any claims by Buyer for omissions or shortages in a shipment shall be waived unless Seller receives notice thereof within 30 days after Buyer's receipt of the shipment.

3. Delivery: Unless otherwise provided on the face hereof, delivery shall be made F.O.B. Seller's plant. Regardless of the method of delivery, however, risk of loss shall pass to Buyer upon Seller's delivery to a carrier. Any delivery dates shown are approximate only and Seller shall have no liability for any delays in delivery.

4. Warranty: Seller warrants that the items sold hereunder shall be free from defects in material or workmanship for a period of 18 months from date of shipment from Parker Hannifin Corporation. THIS WARRANTY COMPRISES THE SOLE AND ENTIRE WARRANTY PERTAINING TO ITEMS PROVIDED HEREUNDER. SELLER MAKES NO OTHER WARRANTY, GUARANTEE, OR REPRESENTATION OF ANY KIND WHATSOEVER. ALL OTHER WARRANTIES, INCLUDING BUT NOT LIMITED TO, MERCHANTABILITY AND FITNESS FOR PURPOSE, WHETHER EXPRESS, IMPLIED, OR ARISING BY OPERATION OF LAW, TRADE USAGE, OR COURSE OF DEALING ARE HEREBY DISCLAIMED.

NOTWITHSTANDING THE FOREGOING, THERE ARE NO WARRANTIES WHATSOEVER ON ITEMS BUILT OR ACQUIRED WHOLLY OR PARTIALLY, TO BUYER'S DESIGN OR SPECIFICATIONS.

5. Limitation of Remedy: SELLER'S LIABILITY ARISING FROM OR IN ANY WAY CONNECTED WITH THE ITEMS SOLD OR THIS CONTRACT SHALL BE LIMITED EXCLUSIVELY TO REPAIR OR REPLACEMENT OF THE ITEMS SOLD OR REFUND OF THE PURCHASE PRICE PAID BY BUYER, AT SELLER'S SOLE OPTION. IN NO EVENT SHALL SELLER BE LIABLE FOR ANY INCIDENTAL, CONSEQUENTIAL OR SPECIAL DAMAGES OF ANY KIND OR NATURE WHATSOEVER, INCLUDING BUT NOT LIMITED TO LOST PROFITS ARISING FROM OR IN ANY WAY CONNECTED WITH THIS AGREEMENT OR ITEMS SOLD HEREUNDER, WHETHER ALLEGED TO ARISE FROM BREACH OF CONTRACT, EXPRESS OR IMPLIED WARRANTY, OR IN TORT, INCLUDING WITHOUT LIMITATION, NEGLIGENCE, FAILURE TO WARN OR STRICT LIABILITY.

6. Changes, Reschedules and Cancellations: Buyer may request to modify the designs or specifications for the items sold hereunder as well as the quantities and delivery dates thereof, or may request to cancel all or part of this order, however, no such requested modification or cancellation shall become part of the contract between Buyer and Seller unless accepted by Seller in a written amendment to this Agreement. Acceptance of any such requested modification or cancellation shall be at Seller's discretion, and shall be upon such terms and conditions as Seller may require.

7. Special Tooling: A tooling charge may be imposed for any special tooling, including without limitations, dies, fixtures, molds and patterns, acquired to manufacture items sold pursuant to this contract. Such special tooling shall be and remain Seller's property notwithstanding payment of any charges by Buyer. In no event will Buyer acquire any interest in apparatus belonging to Seller which is utilized in the manufacture of the items sold hereunder, even if such apparatus has been specially converted or adapted for such manufacture and notwithstanding any

charges paid by Buyer. Unless otherwise agreed, Seller shall have the right to alter, discard or otherwise dispose of any special tooling or other property in its sole discretion at any time.

8. Buyer's Property: Any designs, tools, patterns, materials, drawings, confidential information or equipment furnished by Buyer, or any other items which become Buyer's property, may be considered obsolete and may be destroyed by Seller after two (2) consecutive years have elapsed without Buyer placing an order for the items which are manufactured using such property. Seller shall not be responsible for any loss or damage to such property while it is in Seller's possession or control.

9. Taxes: Unless otherwise indicated on the face hereof, all prices and charges are exclusive of excise, sales, use, property, occupational or like taxes which may be imposed by any taxing authority upon the manufacture, sale or delivery of the items sold hereunder. If any such taxes must be paid by Seller or if Seller is liable for the collection of such tax, the amount thereof shall be in addition to the amounts for the items sold. Buyer agrees to pay all such taxes or to reimburse Seller therefore upon receipt of its invoice. If Buyer claims exemption from any sales, use or other tax imposed by any taxing authority, Buyer shall save Seller harmless from and against any such tax, together with any interest or penalties thereon which may be assessed if the items are held to be taxable.

10. Indemnity For Infringement of Intellectual Property Rights: Seller shall have no liability for infringement of any patents, trademarks, copyrights, trade dress, trade secrets or similar rights except as provided in this Part 10. Seller will defend and indemnify Buyer against allegations of infringement of U.S. patents, U.S. trademarks, copyrights, trade dress and trade secrets (hereinafter "Intellectual Property Rights"). Seller will defend at its expense and will pay the cost of any settlement or damages awarded in an action brought against Buyer based on an allegation that an item sold pursuant to this contract infringes the Intellectual Property Rights of a third party. Seller's obligation to defend and indemnify Buyer is contingent on Buyer notifying Seller within ten (10) days after Buyer becomes aware of such allegations of infringement, and Seller having sole control over the defense of any allegations or actions including all negotiations for settlement or compromise. If an item sold hereunder is subject to a claim that it infringes the Intellectual Property Rights of a third party, Seller may, at its sole expense and option, procure for Buyer the right to continue using said item, replace or modify said item so as to make it noninfringing, or offer to accept return of said item and return the purchase price less a reasonable allowance for depreciation. Notwithstanding the foregoing, Seller shall have no liability for claims of infringement based on information provided by Buyer, or directed to items delivered hereunder for which the designs are specified in whole or part by Buyer, or infringements resulting from the modification, combination or use in a system of any item sold hereunder. The foregoing provisions of this Part 10 shall constitute Seller's sole and exclusive liability and Buyer's sole and exclusive remedy for infringement of Intellectual Property Rights.

If a claim is based on information provided by Buyer or if the design for an item delivered hereunder is specified in whole or in part by Buyer, Buyer shall defend and indemnify Seller for all costs, expenses or judgments resulting from any claim that such item infringes any patent, trademark, copyright, trade dress, trade secret or any similar right.

11. Force Majeure: Seller does not assume the risk of and shall not be liable for delay or failure to perform any of Seller's obligations by reason of circumstances beyond the reasonable control of Seller (hereinafter "Events of Force Majeure"). Events of Force Majeure shall include without limitation, accidents, acts of God, strikes or labor disputes, acts, laws, rules or regulations of any government or government agency, fires, floods, delays or failures in delivery of carriers or suppliers, shortages of materials and any other cause beyond Seller's control.

12. Entire Agreement/Governing Law: The terms and conditions set forth herein, together with any amendments, modifications and any different terms or conditions expressly accepted by Seller in writing, shall constitute the entire Agreement concerning the items sold, and there are no oral or other representations or agreements which pertain thereto. This Agreement shall be governed in all respects by the law of the State of Ohio. No actions arising out of sale of the items sold hereunder or this Agreement may be brought by either party more than two (2) years after the cause of action accrues.

D



Parker Hannifin Corporation
Parker-Origa
100 West Lake Drive
Glendale Heights, IL 60139 USA

Phone 630-871-8300
fax 630-871-1515
toll free 800-695-5984
email: info-hous-market@parker.com
website www.parker.com/pneu/rodless

